

FRI

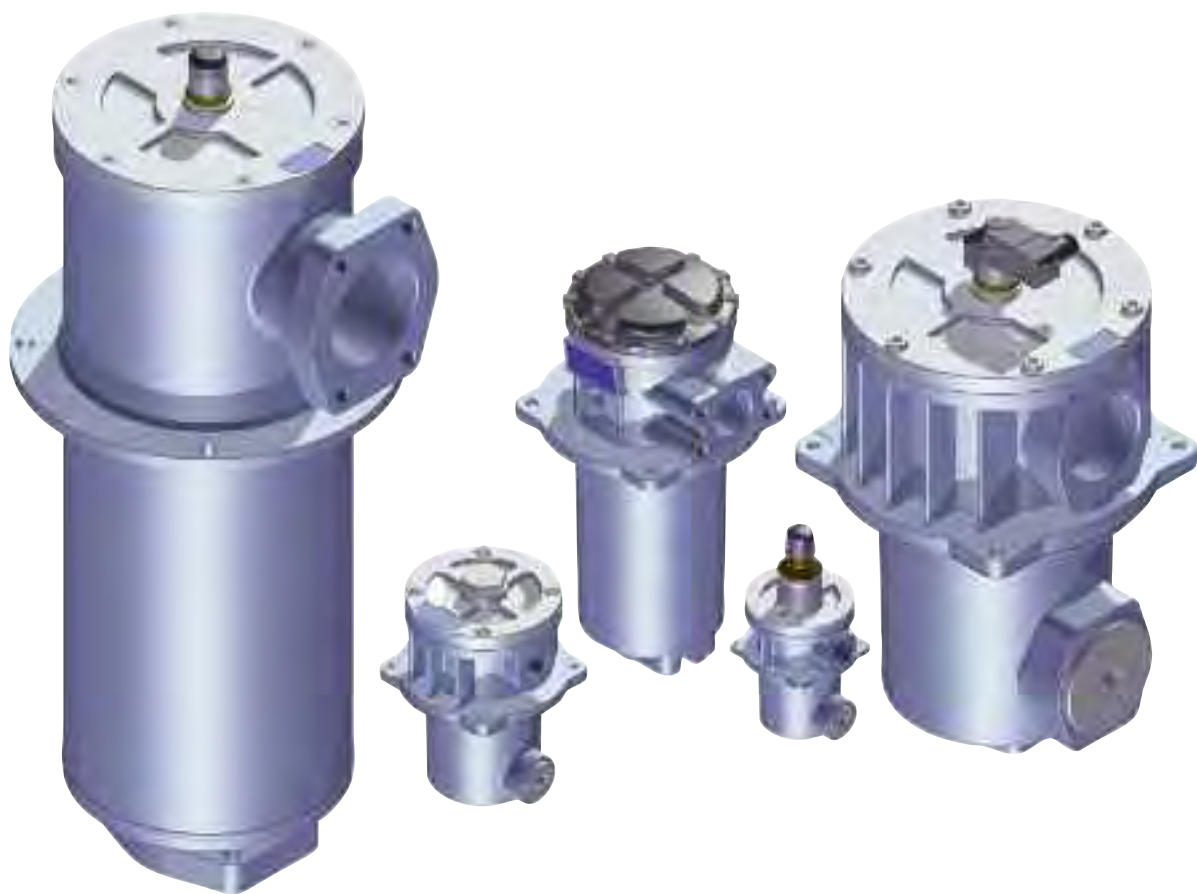

Maximum pressure 20 bar
Flow rates to 1500 l/min

Filter housing (Materials)

- Filter body: Aluminium: FRI 255
Anodized Aluminium: FRI 025-040-100-250-630
Phosphated Steel: FRI 850
- Cover: Nylon (only for: FRI 255)
Anodized Aluminium (all the other)
- Valve: Nylon - Steel

Pressure

- Working pressure: 20 bar

Temperature

- From -25 °C to +110 °C

Bypass valve

- Opening pressure 2,4 bar \pm 10%

Δp Elements type

- Series N elements: 10 bar
- Oil flow from outside to inside.

Seals

- Standard NBR series A
- Optional FPM series V

Weights (kg)

- FRI 025 1,0
- FRI 040 2,0
- FRI 100 3,8
- FRI 250 6,3
- FRI 255 4,2
- FRI 630 13,8
- FRI 850 48,0

Volumes (dm³)

- FRI 025 0,28
- FRI 040 0,70
- FRI 100 1,09
- FRI 250 2,60
- FRI 255 3,2
- FRI 630 7,05
- FRI 850 21,5

Compatibility (to ISO 2943)

- Housings compatible with:
Mineral oils, synthetic fluids.
Aqueous emulsions, water and glycol.
- The filter elements are compatible with:
Mineral oils, synthetic fluids.
Aqueous emulsions, water and glycol
(series W required).
- NBR seals series A, compatible with:
Mineral oils, synthetic fluids.
Aqueous emulsions, water and glycol.
- FPM seals V series, compatible with:
Synthetic fluids type HS-HFDR-HFDS-HFDU

Filter housings Δp pressure drop

The curves are plotted utilising mineral oil with density of 0.86 kg/dm³ to ISO 3968.

Δp varies proportionally with density.

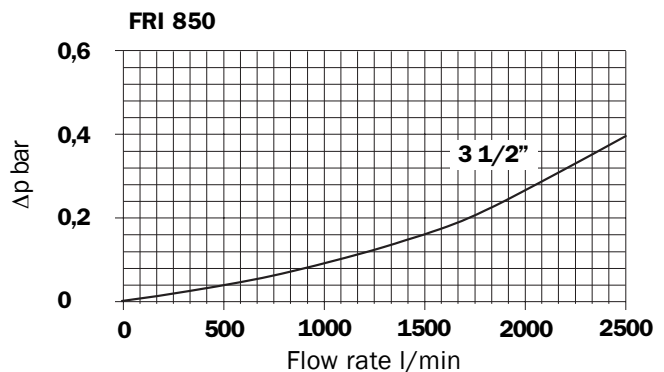
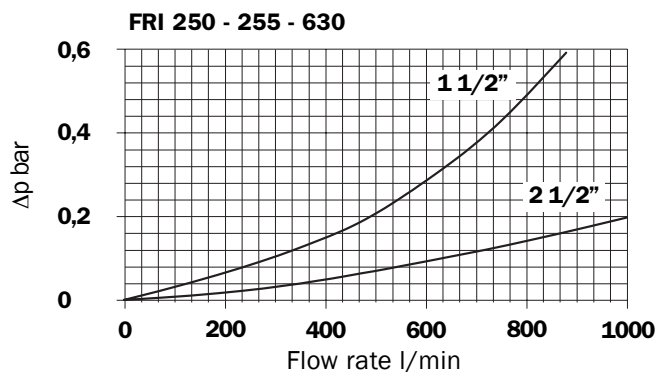
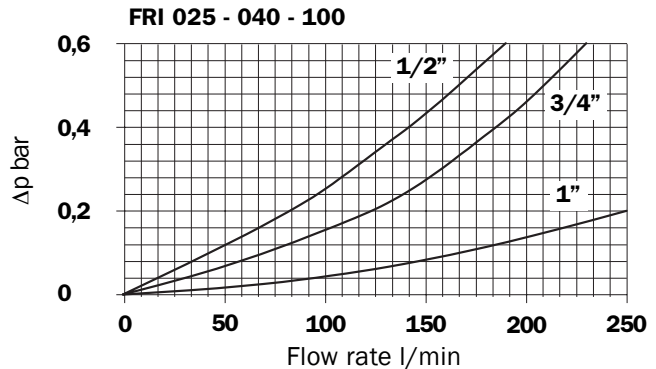

Valves

Bypass valve pressure drop

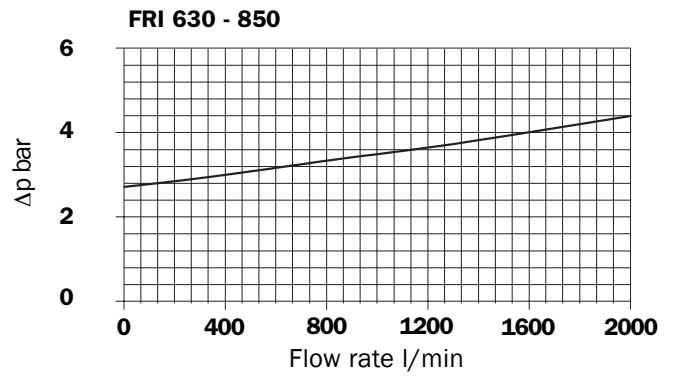
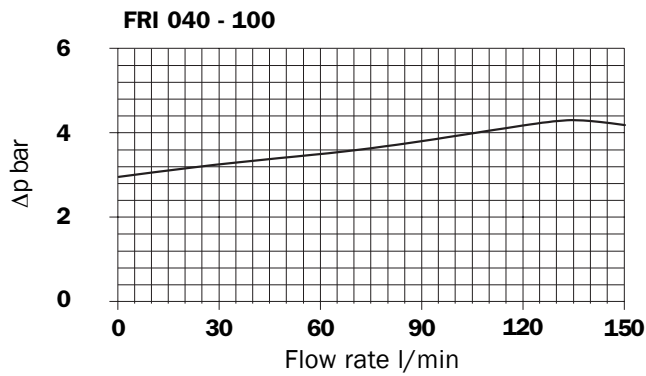
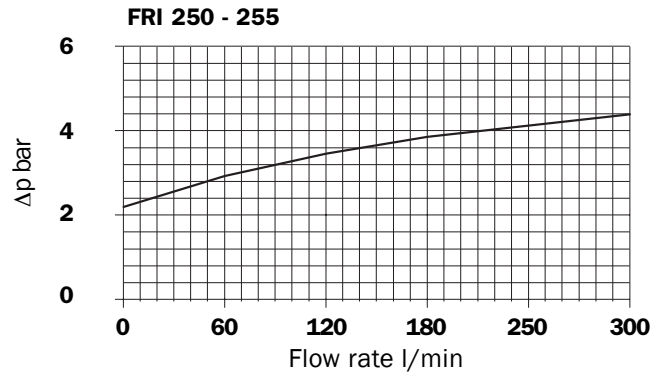
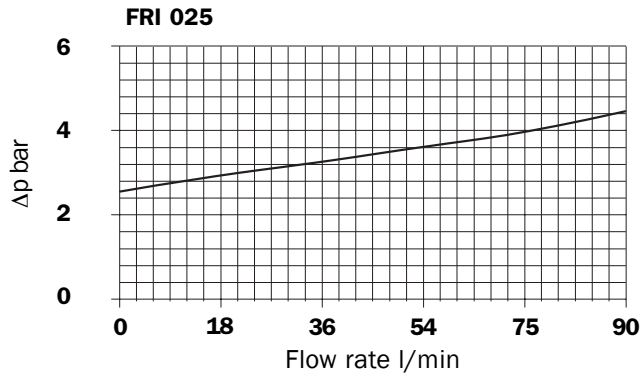

Recommended maximum flow rate

- Pressure drop of filter assembly equal to Δp 0,5 bar.
- Oil kinematic viscosity 30 mm²/s (cSt).
- Density 0,86 kg/dm³.

Filtration

	Length	A03	A06	A10	A16	A25	P10	P25	M25 - M60 - M90
FRI 025	1	6	10	16	19	43	43	47	50*
FRI 040	1	18	22	42	44	80	80	80	80*
FRI 100	1	32	33	88	91	140	140	140	140*
FRI 250 - 255	1	143	178	270	300	350	350	350	350*
FRI 630	1	240	278	507	575	700	700	700	700*
FRI 850	1	440	540	970	1140	1600	1600	1600	1600*

* Maximum flow recommended

FRI 025 - 040

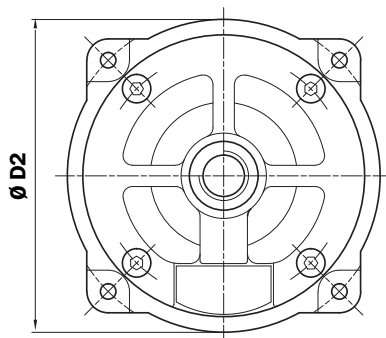
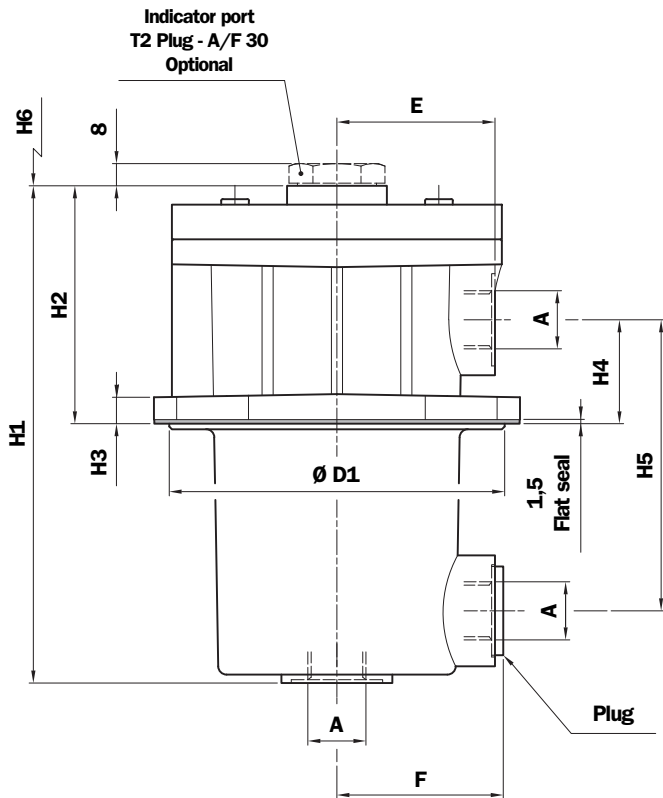

Holes on the tank

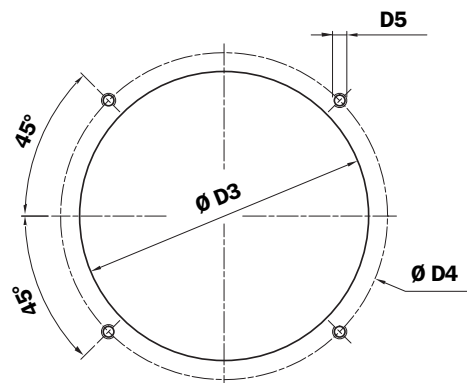

Thread connections

Type	A	
	FRI 025	FRI 040
G1	G 1/2"	G 3/4"
G2	1/2" NPT	3/4" NPT
G3	SAE 8 - 3/4" - 16 UNF	SAE 12 - 1.1/16" - 12 UN

Filter Length	H1 mm	H2 mm	H3 mm	H4 mm	H5 mm	H6 mm	D1 mm	D2 mm	D3 mm	D4 mm	D5 mm	E mm	F mm
FRI 025	140	73	6,5	21	62,5	115	83,5	89	84,5	95	M5	44	46
FRI 040	180	86	10	38	105	135	121	132	122	138	M6	57	60

FRI 100 - 250 - 630

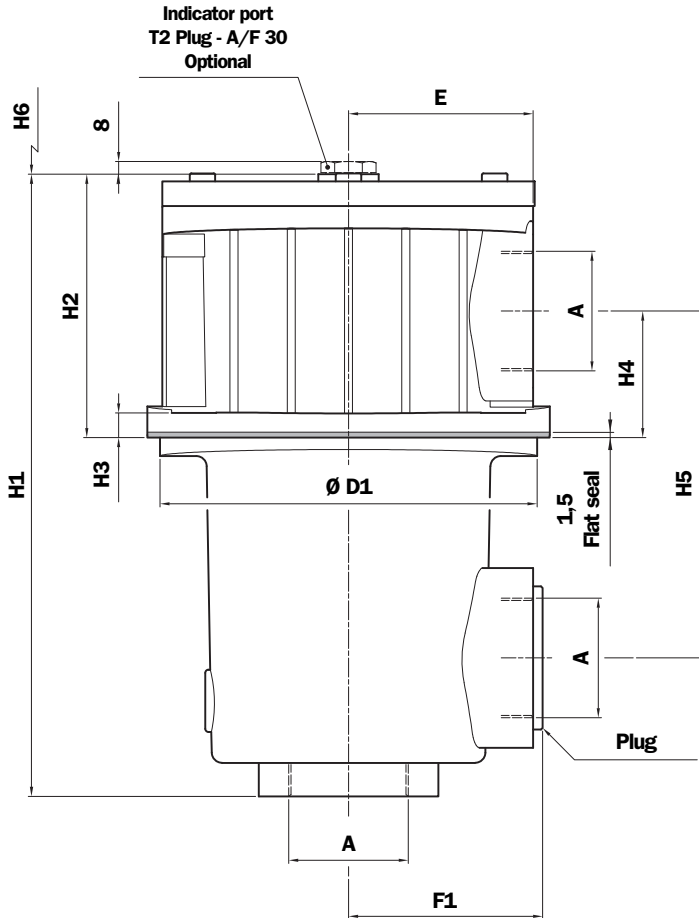

Flange connections

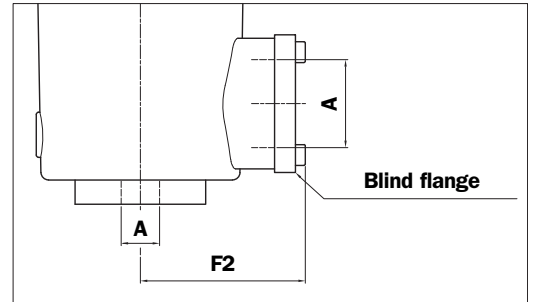

Holes on the tank

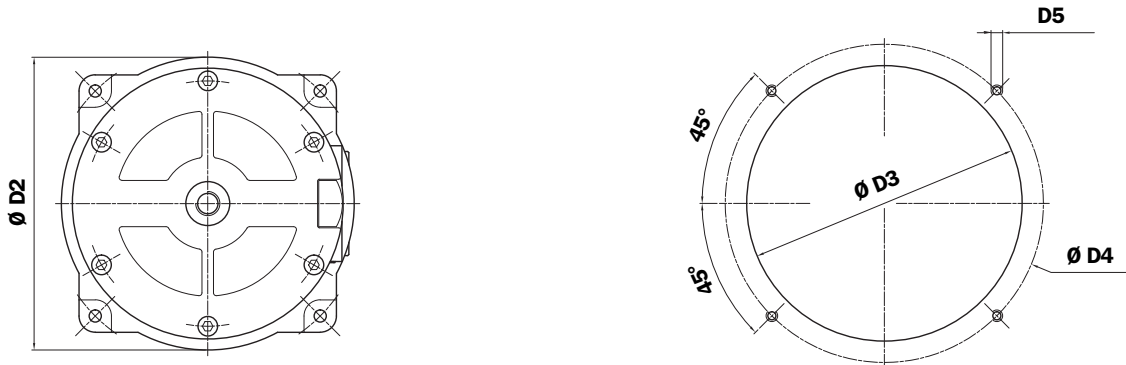

Thread connections

Type	A		
	FRI 100	FRI 250	FRI 630
G1	G 1"	G 1 1/2"	G 2 1/2"
G2	1" NPT	1 1/2" NPT	2 1/2" NPT
G3	SAE 16 - 1.5/16" - 12 UN	SAE 24 - 1.7/8" - 12 UN	SAE 32 - 2 1/2" - 12 UN

Flange connections*

Type	A		
	FRI 100	FRI 250	FRI 630
F1	1" SAE 3000 psi/M	1 1/2" SAE 3000 psi/M	2 1/2" SAE 3000 psi/M
F2	1" SAE 3000 psi/UNC	1 1/2" SAE 3000 psi/UNC	2 1/2" SAE 3000 psi/UNC

*Connections table "DN/SAE flange" see page 5

Filter Length	H1 mm	H2 mm	H3 mm	H4 mm	H5 mm	H6 mm	D1 mm	D2 mm	D3 mm	D4 mm	D5 mm	E mm	F1 mm	F2 mm
FRI 100	245	106	12	51	140	175	135	146	136	154	M6	67	73	90
FRI 250	335	129	14	59	177	265	162	174	163	180	M8	82	86	108
FRI 630	391	166	16	80	218	300	237	253	238	275	M10	116	122	143

FRI 850

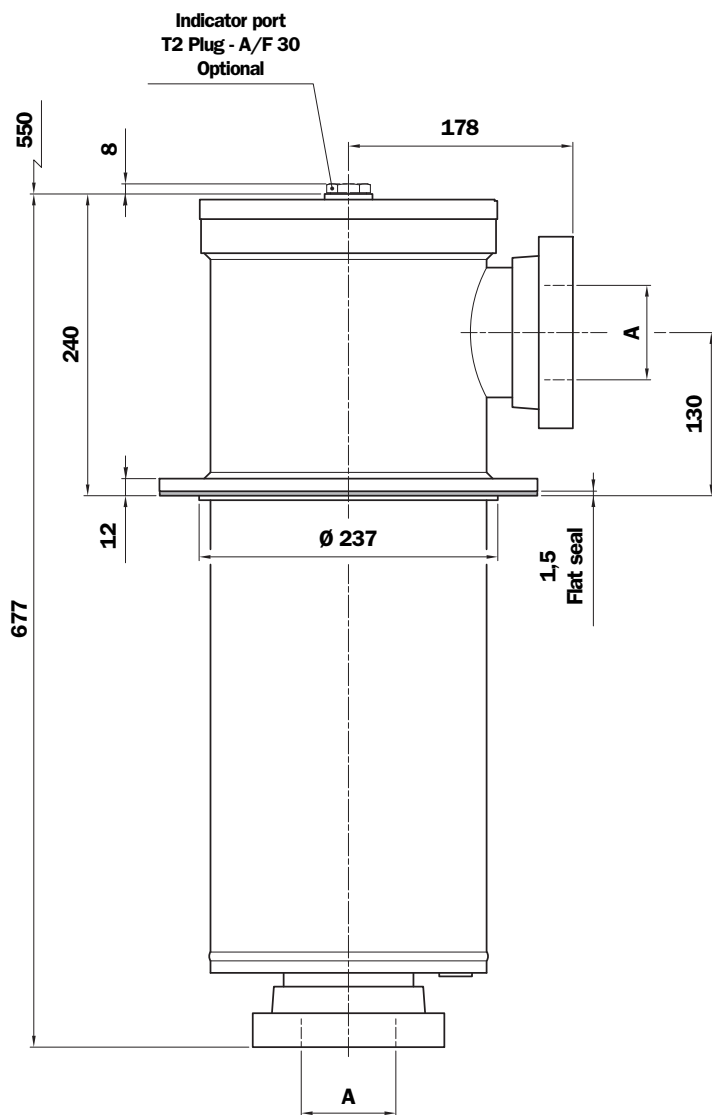

Holes on the tank

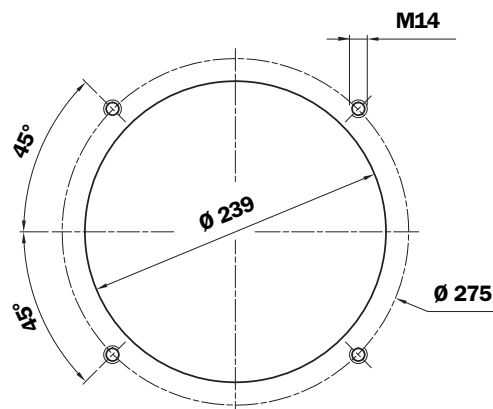
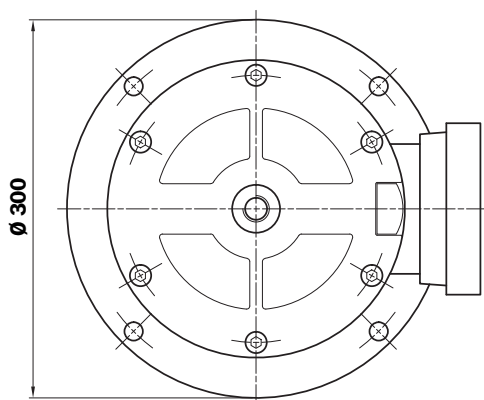

Flange connections*

Type	A
F1	3 1/2" SAE 3000 psi/M
F2	3 1/2" SAE 3000 psi/UNC

*Connections table "DN - SAE flange" see page 5

FRI 255

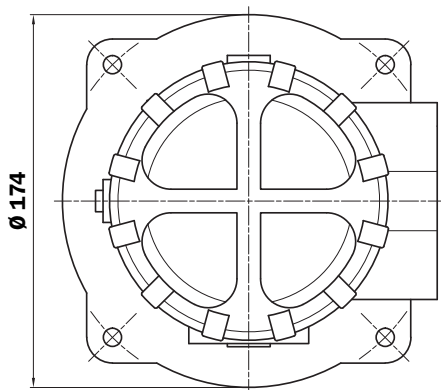
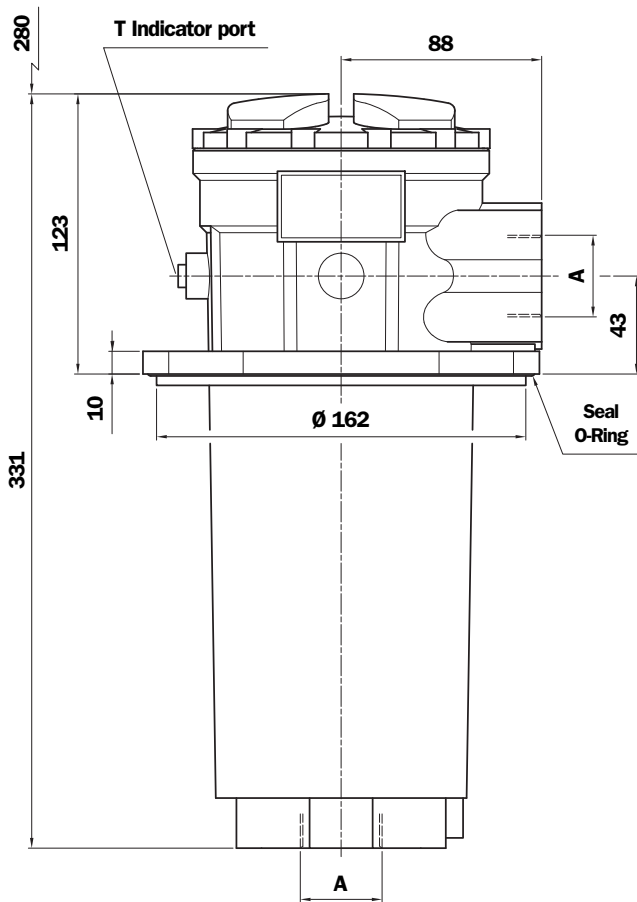

Holes on the tank

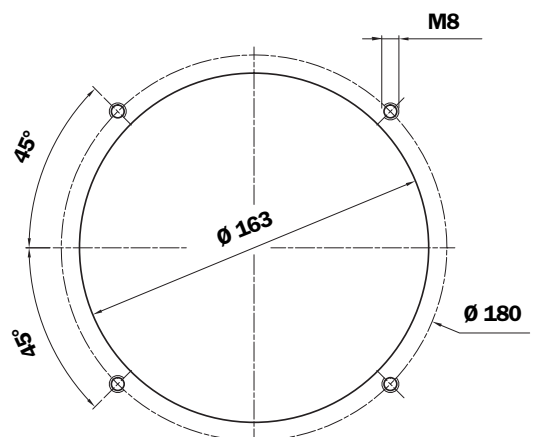

Thread connections

Type	A	T
G1	G 1 1/2"	G 1/8"
G2	1 1/2" NPT	G 1/8"
G3	SAE 24 - 1 7/8" - 12 UN	G 1/8"
G4	G 1 1/4"	G 1/8"
G5	1 1/4" NPT	G 1/8"
G6	SAE 20 - 1 5/8" - 12 UN	G 1/8"

Flange connections*

Type	A	T
F1	1 1/2" SAE 3000 psi/M	G 1/8"
F2	1 1/2" SAE 3000 psi/UNC	G 1/8"

*Connections table "DN - SAE flange" see page 5

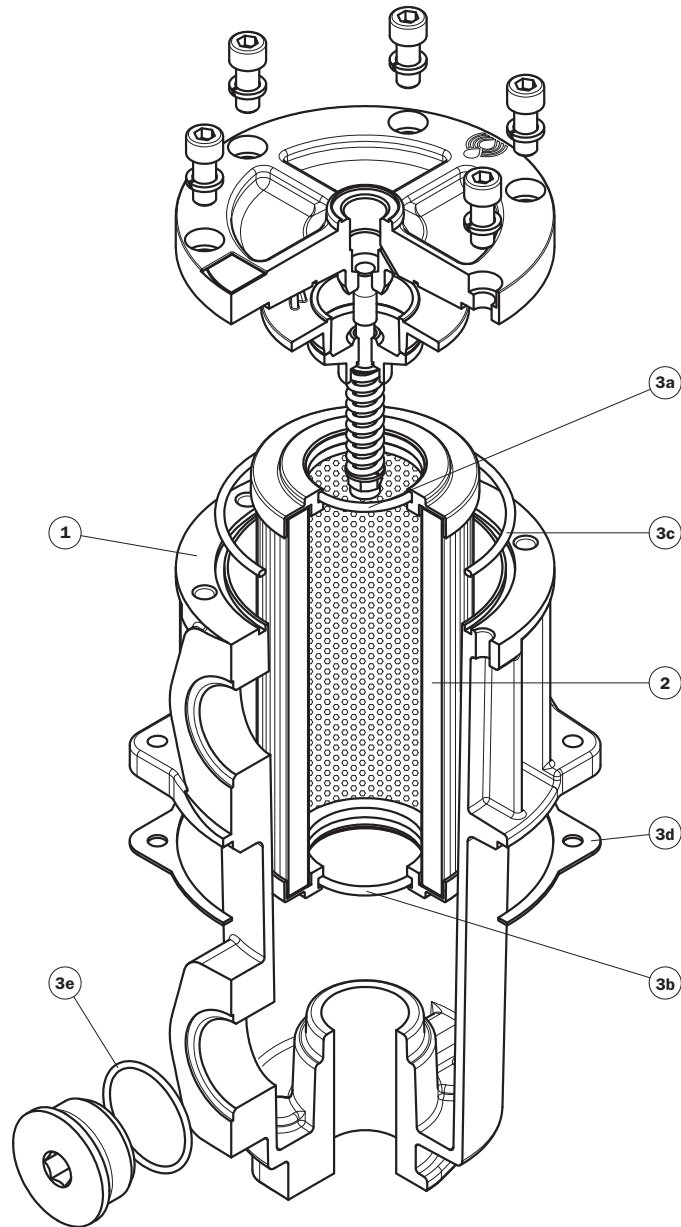

Item	Description	Q.ty	FILTER Series			
			FRI 025		FRI 040	
1	Filter assembly	1	See order table			
2	Filter element	1	See order table			
3	Seal Kit	1	NBR 02050213	FPM 02050220	NBR 02050214	FPM 02050221
3a	Filter element top seal	1	O-R 3106 Ø 25,65 x 2,62		O-R 4137 Ø 34,52 x 3,53	
3b	Filter element bottom seal	1	O-R 3093 Ø 23,47 x 2,62		O-R 4137 Ø 34,52 x 3,54	
3c	Cover seal	1	O-R 3243 Ø 61,60 x 2,62		O-R 4350 Ø 88,50 x 3,53	
3d	Head seal	1	01026404		01026400	
3e	Plug seal GAS thread	1	01017055		01017030	
	Plug seal SAE thread	1	O-R 1064 Ø 16,36 x 2,20		O-R 1092 Ø 23,47 x 2,95	

Spare parts

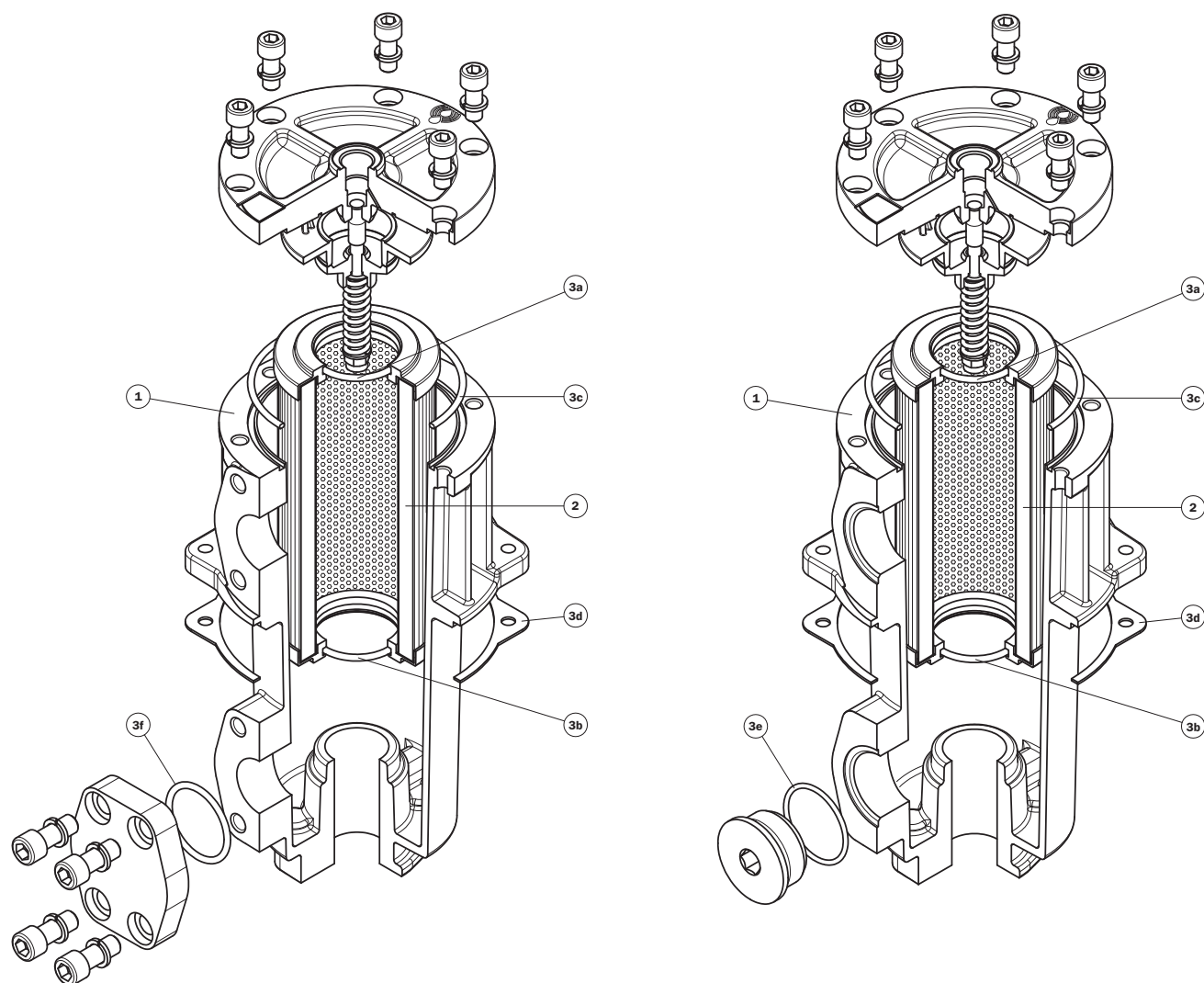

Item	Description	Q.ty	FILTER Series					
			FRI 100		FRI 250		FRI 630	
1	Filter assembly	1	See order table					
2	Filter element	1	See order table					
3	Seal Kit	1	NBR 02050215	FPM 02050222	NBR 02050216	FPM 02050223	NBR 02050217	FPM 02050224
3a	Filter element top seal	1	O-R 4137 Ø 34,52 x 3,53		O-R Metric Ø 50 x 4		O-R 177 Ø 74,61 x 3,53	
3b	Filter element bottom seal	1	O-R 4137 Ø 34,52 x 3,53		O-R Metric Ø 50 x 4		O-R 177 Ø 74,61 x 3,53	
3c	Cover seal	1	O-R 4387 Ø 98,02 x 3,53		O-R 4475 Ø 120,20 x 3,53		O-R 233 Ø 181,00 x 6,99	
3d	Head seal	1	01026401		01026402		01026403	
3e	Plug seal GAS thread	1	O-R 2131 Ø 33,05 x 1,78		O-R 3193 Ø 48,89 x 2,62		O-R 3325 Ø 82,22 x 2,62	
	Plug seal SAE thread	1	O-R 1117 Ø 29,74 x 2,95		O-R 1172 Ø 43,69 x 3		O-R 1234 Ø 59,36 x 3	
3f	Blind flange seal	1	O-R 4131 Ø 32,93 x 3,53		O-R 150 Ø 46,04 x 3,53		O-R 171 Ø 68,26 x 3,53	

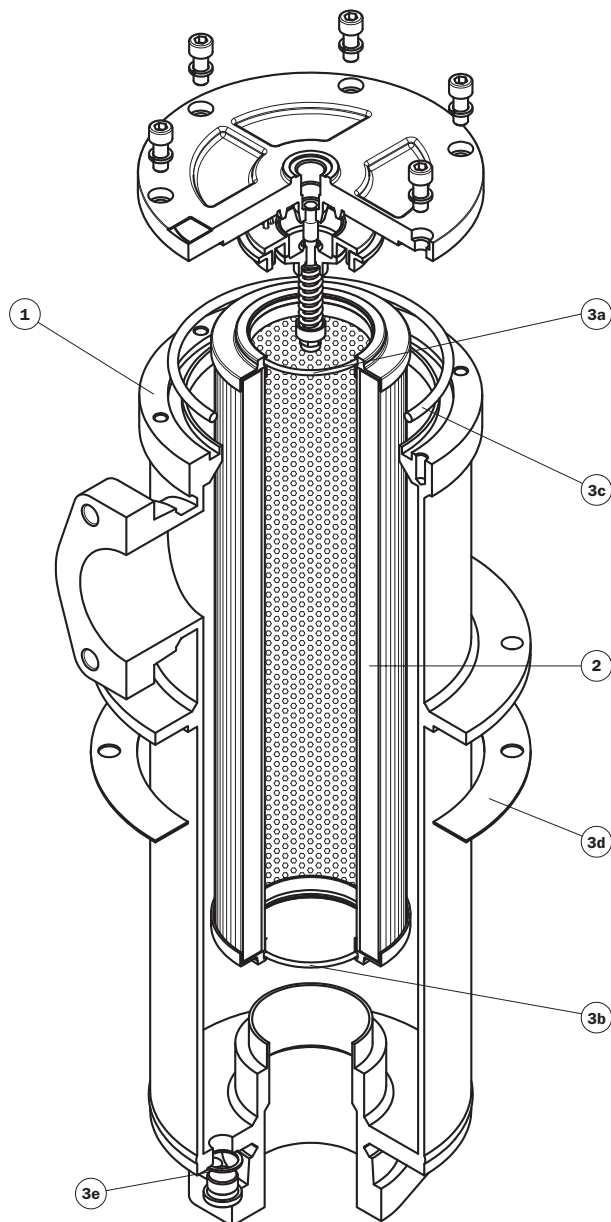

Item	Description	Q.ty	FILTER Series FRI 850	
1	Filter assembly	1	See order table	
2	Filter element	1	See order table	
3	Seal Kit	1	NBR 02050218	FPM 02050225
3a	Filter element top seal	1	O-R 4337 Ø 85,32 x 3,53	
3b	Filter element bottom seal	1	O-R 4337 Ø 85,32 x 3,53	
3c	Cover seal	1	O-R 233 Ø 181,00 x 6,99	
3d	Head seal	1	01026320	01026326
3e	Plug seal	1	01017055	

Spare parts

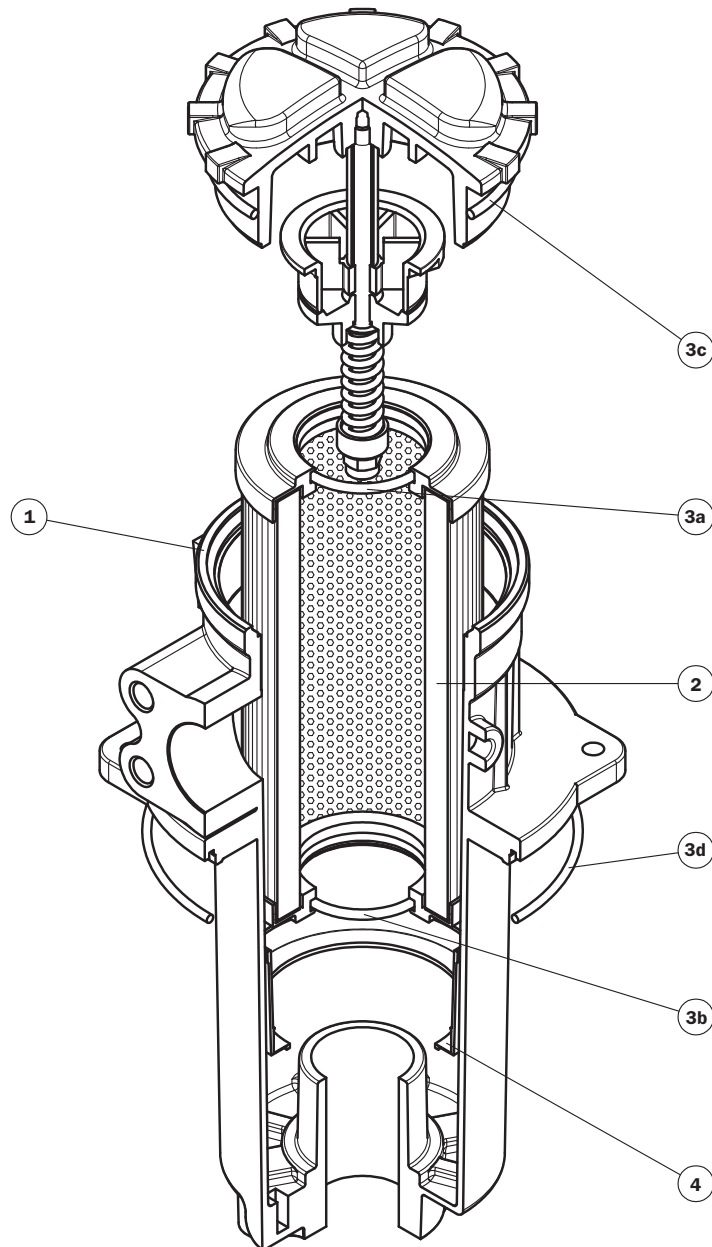

Item	Description	Q.ty	FILTER Series FRI 255	
1	Filter assembly	1	See order table	
2	Filter element	1	See order table	
3	Seal Kit	1	NBR 02050013	FPM 02050014
3a	Filter element top seal	1	O-R Metric Ø 50 x 4	
3b	Filter element bottom seal	1	O-R Metric Ø 50 x 4	
3c	Cover seal	1	O-R Metric Ø 113 x 4	
3d	Head seal	1	O-R 4650 Ø 164,70 x 3,53	
4	Contamination retainer binder	1	01060301	

Ordering information FRI

Filter assembly

FRI

Example: FRI

1	2	3	4	5	6	8
<input type="checkbox"/>	<input type="checkbox"/>	<input type="checkbox"/>	<input type="checkbox"/>	<input type="checkbox"/>	<input type="checkbox"/>	<input type="checkbox"/>
040	B	A	G1	A10	N	P01

Filter element

CU

Example: CU

1	5	7	8
<input type="checkbox"/>	<input type="checkbox"/>	<input type="checkbox"/>	<input type="checkbox"/>
040	A10	N	P01

1 - Style

Filter	Filter element
025	025
040	040
100	100
250	250
255	250
630	630
850	850

5 - Filter element

A03	Inorganic microfibre 3 μ	} Absolute filtration βx (c) ≥ 1000
A06	Inorganic microfibre 6 μ	
A10	Inorganic microfibre 10 μ	
A16	Inorganic microfibre 16 μ	
A25	Inorganic microfibre 25 μ	
M25	Wire mesh	} Nominal Filtration
P10	Resin impregnated paper	} Nominal Filtration
P25	Resin impregnated paper	

2 - By-pass valve

B	With bypass
S	Without bypass

6 - Δp Filter element

N	Δp 10 bar
----------	-----------

3 - Filter seals & Treatment

A	NBR
V	FPM
W	NBR, Filter body anodized. Filter element compatible with fluid HFA, HFB, HFC (only for filter element type Axx and Mxx)
Z	FPM, Filter body anodized. Filter element compatible with fluid HFA, HFB, HFC (only for filter element type Axx and Mxx)

7 - Filter element seals

N	NBR
V	FPM
W*	NBR (only for filter element type Axx and Mxx)
Z*	FPM (only for filter element type Axx and Mxx)

8 - Option

P01	MP Filtri standard
------------	--------------------

* Compatible with fluid HFA, HFB, HFC

4 - Connections

FRI 025

Type	A
G1	G 1/2"
G2	1/2" NPT
G3	SAE 8 - 3/4" - 16 UNF

FRI 040

Type	A
G1	G 3/4"
G2	3/4" NPT
G3	SAE 12 - 1 1/16" - 12 UN

FRI 100

Type	A
G1	G 1"
G2	1" NPT
G3	SAE 16 - 1 5/16" - 12 UN
F1	1" SAE 3000 psi/M
F2	1" SAE 3000 psi/UNC

FRI 255

Type	A
G1	G 1 1/2"
G2	1 1/2" NPT
G3	SAE 24 - 1 7/8" - 12 UN
G4	G 1 1/4"
G5	1 1/4" NPT
G6	SAE 20 - 1 5/8" - 12 UN
F1	1 1/2" SAE 3000 psi/M
F2	1 1/2" SAE 3000 psi/UNC

FRI 630

Type	A
G1	G 2 1/2"
G2	2 1/2" NPT
G3	SAE 32 - 2 1/2" - 12 UN
F1	2 1/2" SAE 3000 psi/M
F2	2 1/2" SAE 3000 psi/UNC

FRI 850

Type	A
F1	3 1/2" SAE 3000 psi/M
F2	3 1/2" SAE 3000 psi/UNC

FRI 250

Type	A
G1	G 1 1/2"
G2	1 1/2" NPT
G3	SAE 24 - 1 7/8" - 12 UN
F1	1 1/2" SAE 3000 psi/M
F2	1 1/2" SAE 3000 psi/UNC

Differential indicator FRI (see page 114)
Clogging indicator only for FRI 255 (see page 112)

MP Filtri - The filter functions as described in this bulletin are valid exclusively for original MP Filtri filter elements and replacement parts. All rights reserved

The data in this publication are purely guideline. MP Filtri reserves the right to make changes to the models described herein at any time it deems fit in relation to technical or commercial requirements. The colours of the products shown on the cover are purely guideline. Copyright. All rights reserved.

MFB - Bowl assembly

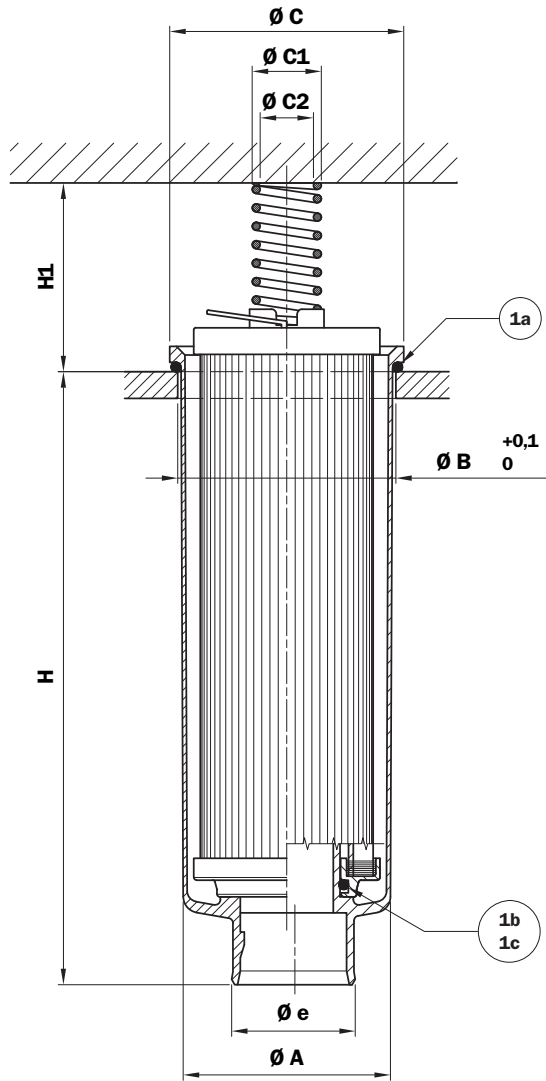

Cover type MPF

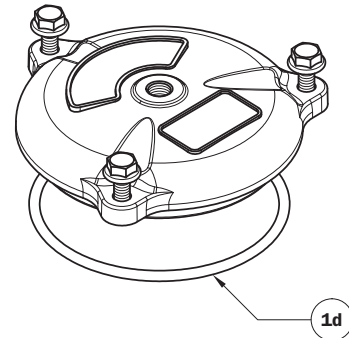

Cover type MPT

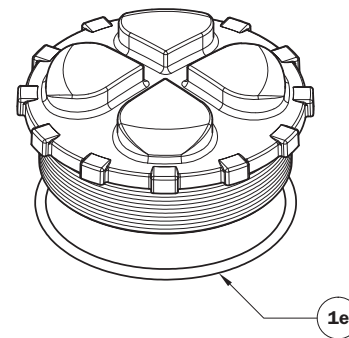

MFB

Size	Filter Length	H mm	H1			Ø e mm	Ø A mm	Ø B mm	Ø C mm	Ø C1 mm	Ø C2 mm
			Without cover	MPF	MPT						
020	1	111									
	2	175	42	-	42	32	51,5	52	56	26	20,5
	3	214									
030	1	92	38	38	-	32	60	60,5	68	26	20,6

Size	Filter Length	H mm	H1			Ø e mm	Ø A mm	Ø B mm	Ø C mm	Ø C1 mm	Ø C2 mm
			Without cover	MPF	MPT						
100	1	107									
	2	154									
	3	232	48	48	58	38	80	80,5	88	26	20
	4	334				46,5					
180	1	234	58	58	-	47	112	112,5	121	33,5	26
	2	447									
190	2	446	58	58	-	50	112	112,5	121	33,5	26

Spare parts

Item	Description	Q.ty	FILTER Series MFB 020		FILTER Series MFB 030		FILTER Series MFB 100		FILTER Series MFB 180		FILTER Series MFB 190	
			NBR	FPM	NBR	FPM	NBR	FPM	NBR	FPM	NBR	FPM
1	Seal Kit	1	02050572	02050573	02050574	02050575	02050555	02050556	02050576	02050577	02050578	02050579
1a	Bowl seal	1	O-R 3200 Ø 50,47 x 2,62		O-R 3225 Ø 56,82 x 2,62		O-R 4312 Ø 78,97 x 3,53		O-R 4425 Ø 107,50 x 3,53		O-R 6425 Ø 107,20 x 5,34	
1b	Filter element seal (length 1-2)	1	O-R 4087 Ø 21,82 x 3,53		O-R 3093 Ø 23,47 x 2,62		O-R 4112 Ø 28,17 x 3,53		O-R 4162 Ø 40,86 x 3,53		O-R Metric Ø 50 x 4	
1c	Filter element seal (length 3-4)	1	O-R 3081 Ø 20,24 x 2,62		-		O-R 4162 Ø 40,86 x 3,53		-		-	
1d	Cover type MPF seal	1	-		O-R 174 Ø 71,44 x 3,53		O-R 4387 Ø 98,02 x 3,53		O-R 4537 Ø 136,10 x 3,53		O-R 4537 Ø 136,10 x 3,53	
1e	Cover type MPT seal	1	O-R Metric Ø 59 x 3		-		O-R Metric Ø 90 x 4		-		-	

Ordering information MFB

Bowl assembly

MFB

Example: MFB

1	2	3	4	5	6	8	9
<input type="checkbox"/>	<input type="checkbox"/>	<input type="checkbox"/>	<input type="checkbox"/>	<input type="checkbox"/>	<input type="checkbox"/>	<input type="checkbox"/>	<input type="checkbox"/>
100	3	A	1	A03	H	E	P01

Filter element

MF

Example: MF

1	2	5	6	7	8	9
<input type="checkbox"/>	<input type="checkbox"/>	<input type="checkbox"/>	<input type="checkbox"/>	<input type="checkbox"/>	<input type="checkbox"/>	<input type="checkbox"/>
100	3	A03	H	B	E	P01

1 - Style

Bowl assembly

020
030
100
180
190

Filter element

020
030
100
180
190

2 - Length

020
030
100
180
190

1	2	3		
1				
1	2	3	4	
1	2			
	2			

3 - Seals

A	NBR
V	FPM

4 - Execution

1	Without cover
2	With flanged cover type MPF (only for size 030-100-180-190)
3	With threaded cover type MPT (only for size 020-100)

5 - Filter element

A03	Inorganic microfibre 3 μ] Absolute filtration $\beta_x(c) \geq 1000$
A06	Inorganic microfibre 6 μ	
A10	Inorganic microfibre 10 μ	
A16	Inorganic microfibre 16 μ	
A25	Inorganic microfibre 25 μ	
M25	Wire mesh] Nominal Filtration
P10	Resin impregnated paper] Nominal Filtration
P25	Resin impregnated paper	

6 - Δp Filter element

N	Δp 10 bar (only for filter element type Pxx and Mxx)
H	Δp 10 bar (only for filter element type Axx)

7 - Filter element seals

B	NBR
V	FPM

8 - By-pass valve

E	3 bar
B	1.75 bar (Omit in the element code - only for 1.75 bar)

9 - Option

P01	MP Filtri standard
------------	--------------------

MP Filtri - The filter functions as described in this bulletin are valid exclusively for original MP Filtri filter elements and replacement parts. All rights reserved

The data in this publication are purely guideline. MP Filtri reserves the right to make changes to the models described herein at any time it deems fit in relation to technical or commercial requirements. The colours of the products shown on the cover are purely guideline. Copyright. All rights reserved.

MPF Multiport



Maximum pressure 8 bar
Flow rates to 750 l/min

Filter housing (Materials)

- Head: Aluminium
- Cover: Nylon (only for: MPF 020-030-100-104-110)
Aluminium (all the other)
- Bowl: Nylon

Pressure

- Working pressure: 8 bar

Temperature

- From -25 °C to +110 °C

Bypass valve

- Opening pressure 1.75 bar \pm 10%
- Opening pressure 3 bar \pm 10%

Δp Elements type

- Series N and H elements: 10 bar
- Oil flow from outside to inside.

Seals

- Standard NBR series A
- Optional FPM series V

MPF FILTERS ARE PROVIDED FOR VERTICAL MOUNTING

Weights (kg)

Length	1	2	3	4
• MPF 020	0,30	-	-	-
• MPF 030	0,40	-	-	-
• MPF 100	0,61	0,64	0,67	0,74
• MPF 104	0,82	0,96	1,02	1,25
• MPF 110	0,64	0,68	0,71	0,78
• MPF 181	2,20	3,00	-	-
• MPF 182	2,30	3,10	-	-
• MPF 184	2,55	3,45	-	-
• MPF 191	-	3,00	-	-
• MPF 192	-	3,10	-	-
• MPF 194	-	3,45	-	-
• MPF 400	3,35	3,65	3,90	-
• MPF 450-451	3,95	4,25	4,50	-
• MPF 750	6,30	-	-	-

Volumes (dm³)

Length	1	2	3	4
• MPF 020	0,26	-	-	-
• MPF 030	0,29	-	-	-
• MPF 100	0,64	0,85	1,20	1,65
• MPF 104	0,64	0,85	1,20	1,65
• MPF 181	2,50	4,00	-	-
• MPF 182	2,50	4,00	-	-
• MPF 184	2,65	4,45	-	-
• MPF 191	-	4,25	-	-
• MPF 192	-	4,25	-	-
• MPF 194	-	4,45	-	-
• MPF 400	3,70	4,60	5,40	-
• MPF 450-451	3,70	4,60	5,40	-
• MPF 750	8,45	-	-	-

Compatibility (to ISO 2943)

- Housings compatible with:
Mineral oils, synthetic fluids.
Aqueous emulsions, water and glycol (series W required).
- The filter elements are compatible with:
Mineral oils, synthetic fluids.
Aqueous emulsions, water and glycol (series W required).
- NBR seals series A, compatible with:
Mineral oils, synthetic fluids.
Aqueous emulsions, water and glycol.
- FPM seals V series, compatible with:
Synthetic fluids type HS-HFDR-HFDS-HFDU

Filter housings Δp pressure drop

The curves are plotted utilising mineral oil with density of 0.86 kg/dm³ to ISO 3968.

Δp varies proportionally with density.

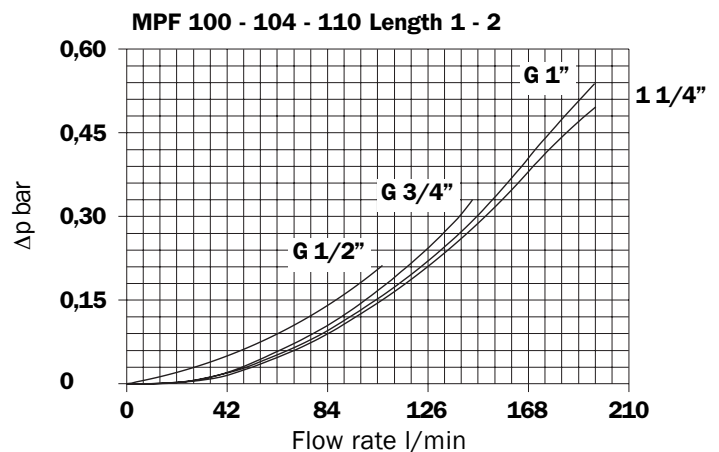
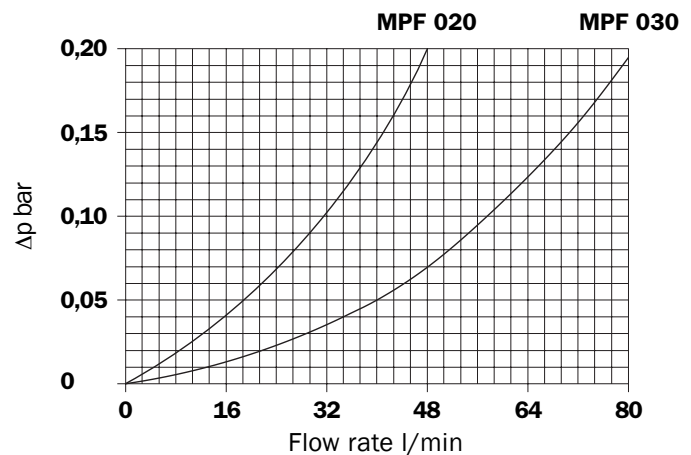

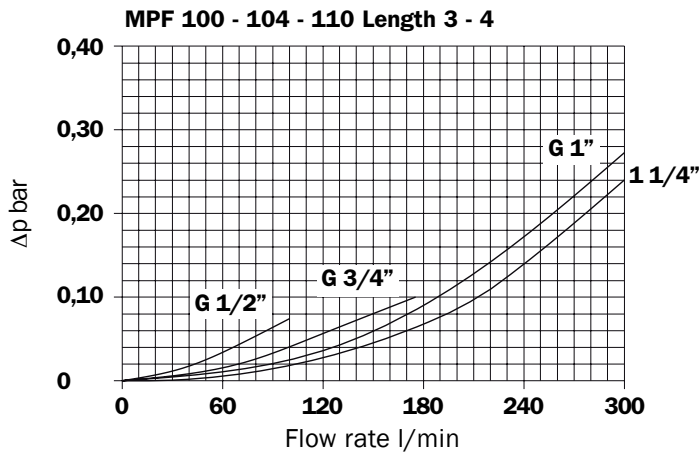

Valves
Bypass valve pressure drop

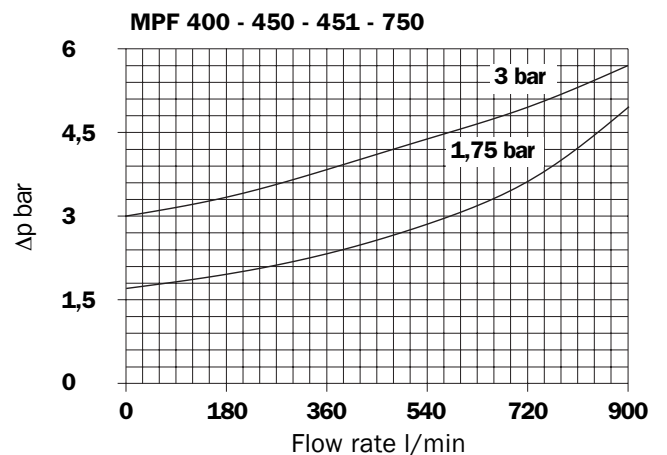
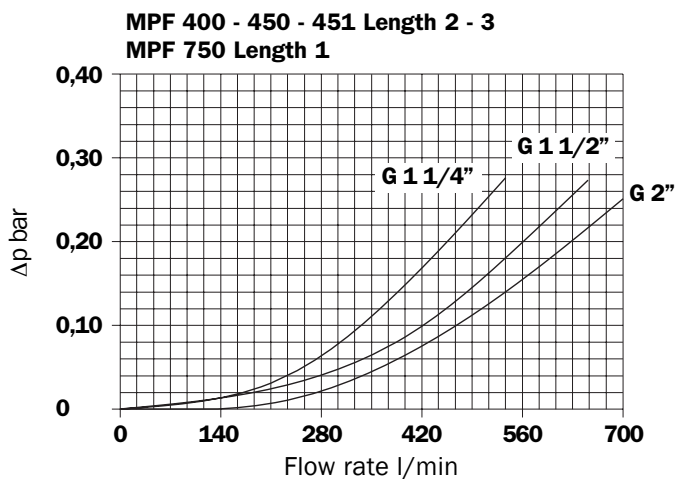
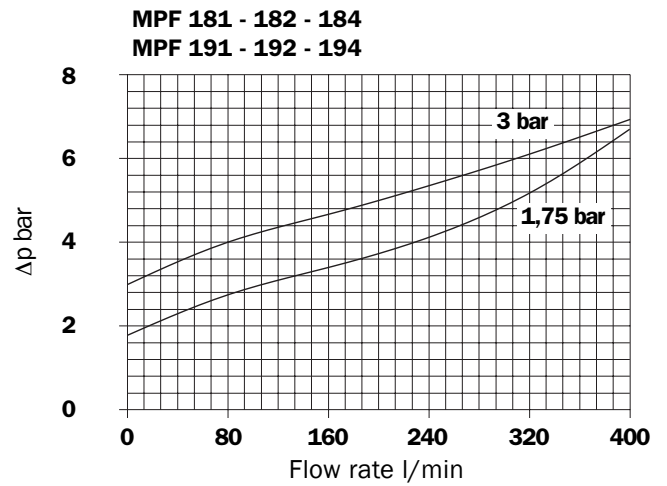
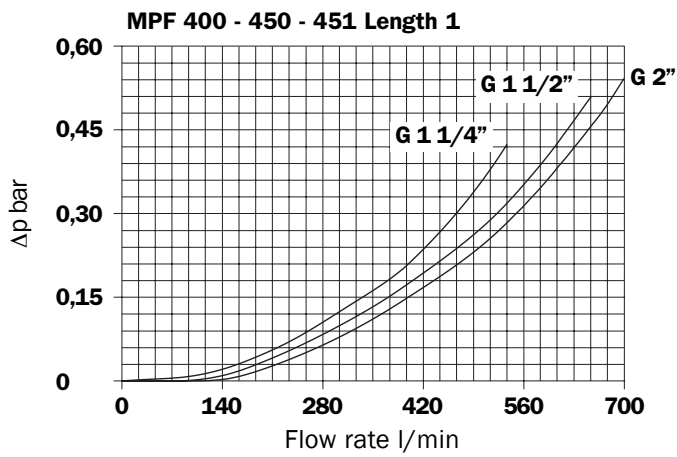
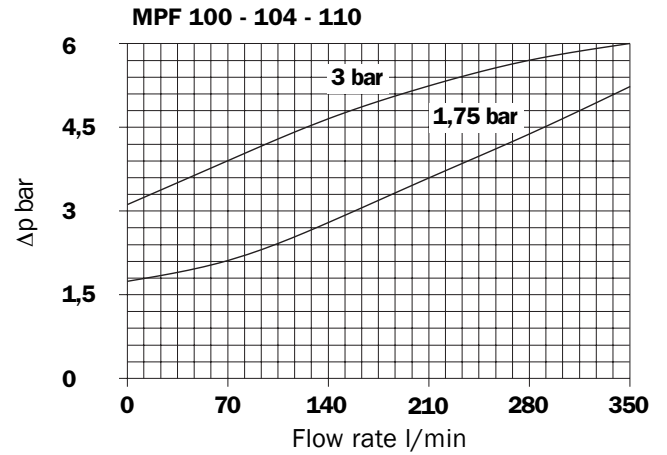
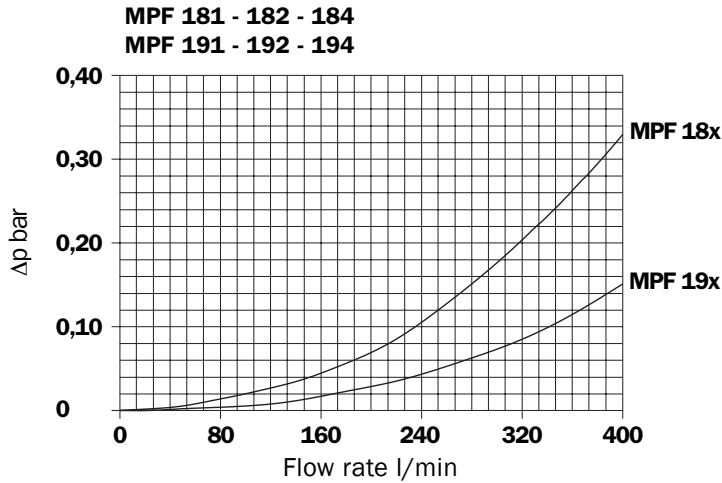
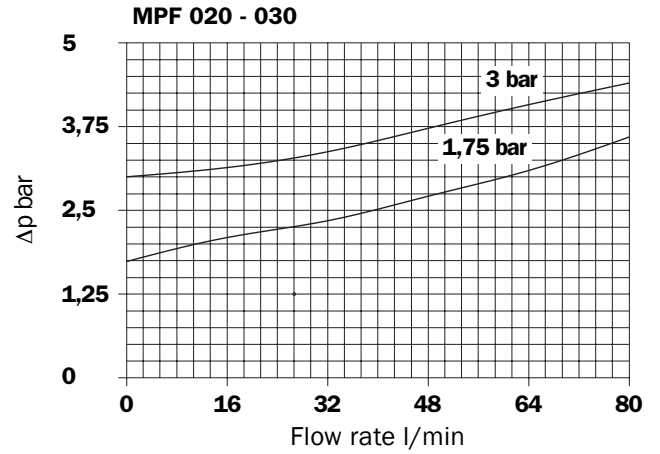

Dimensions

MPF 020

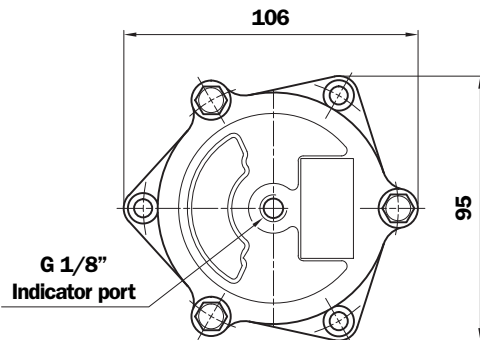
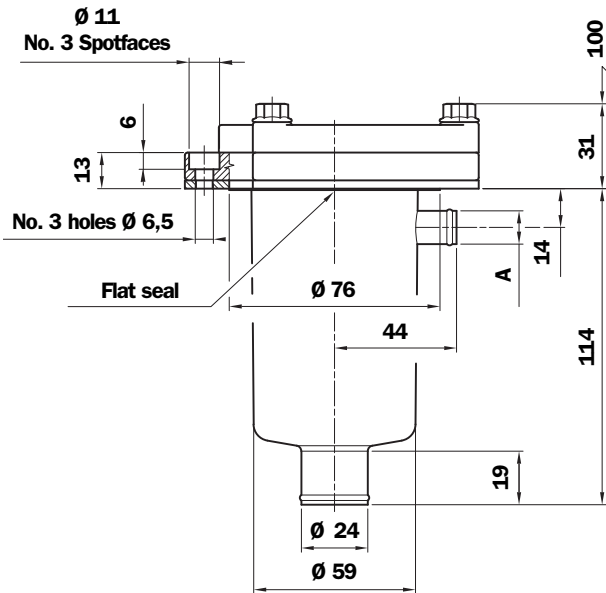

Holes on the tank

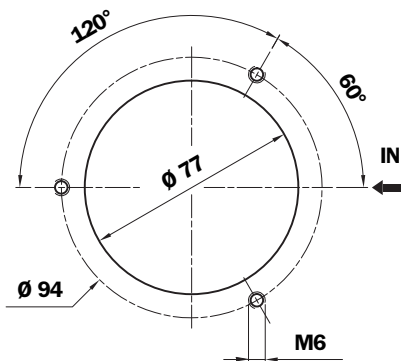

MPF 020 Connection

Type	A
P1	Hose barb - $\varnothing 12$

MPF 030

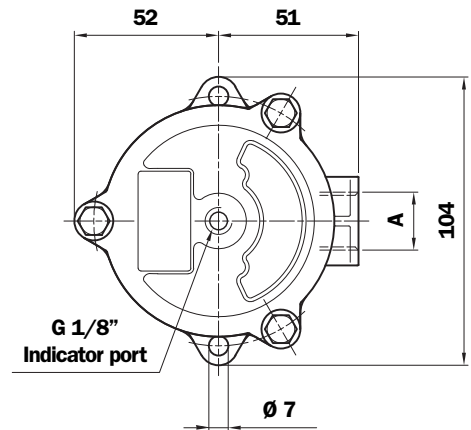
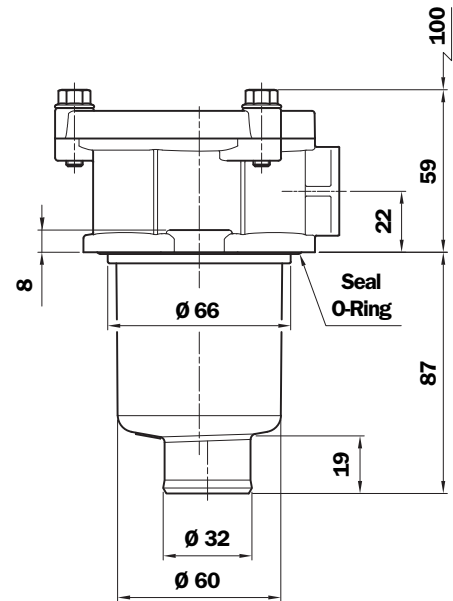

Holes on the tank

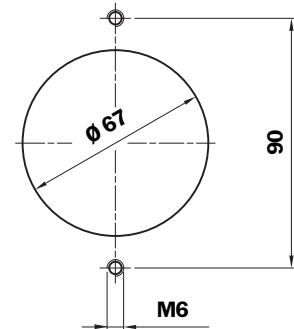

MPF 030 Thread connections

Type	A
G1	G 1/2"
G4	1/2" NPT
G7	SAE 8 - 3/4" - 16 UNF

MPF 100

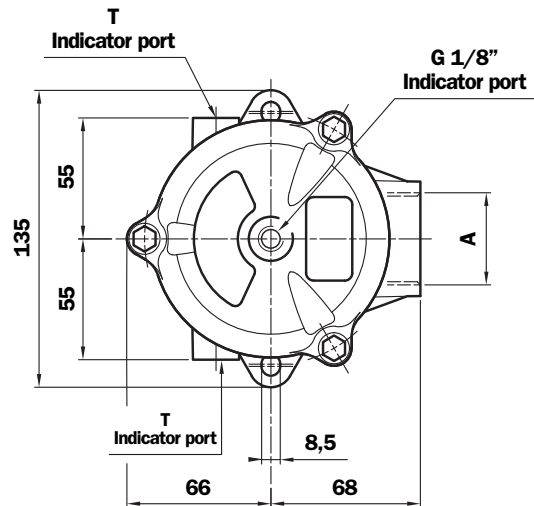
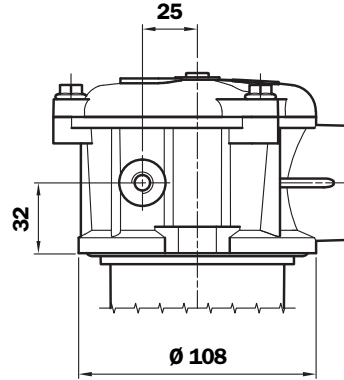
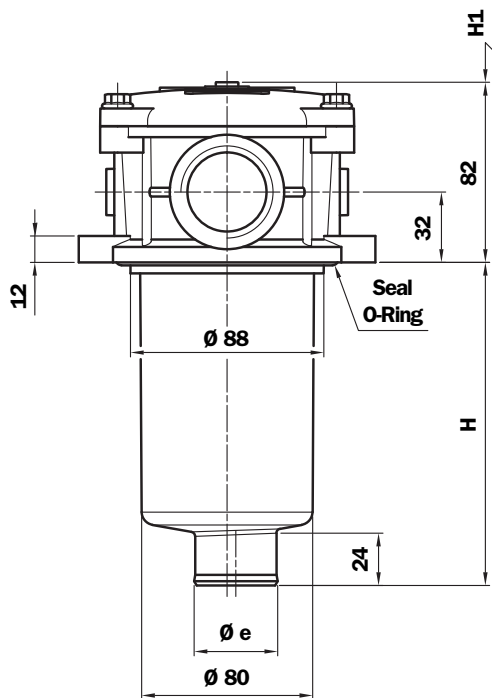

Holes on the tank

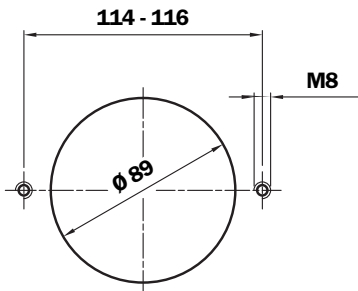

Filter Length	H mm	H1 mm	Ø e mm
1	99	120	38
2	146	170	38
3	224	250	46,5
4	326	350	46,5

T indicator port
G 1/4" - 1/4" NPT
ON REQUEST

Thread connections

Type 1	T	Type 2	T	A
G1	Indicator port not machined	C1	G 1/8"	G 1/2"
G2		C2	G 1/8"	G 3/4"
G3		C3	G 1/8"	G 1"
G10		C10	G 1/8"	G 1 1/4"
G4		C4	1/8" NPT	1/2" NPT
G5		C5	1/8" NPT	3/4" NPT
G6		C6	1/8" NPT	1" NPT
G11		C11	1/8" NPT	1 1/4" NPT
G7		C7	1/8" NPT	SAE 8 - 3/4" - 16 UNF
G8		C8	1/8" NPT	SAE 12 - 1 1/16" - 12 UN
G9		C9	1/8" NPT	SAE 16 - 1 5/16" - 12 UN
G12		C12	1/8" NPT	SAE 20 - 1 5/8" - 12 UN

MPF 104

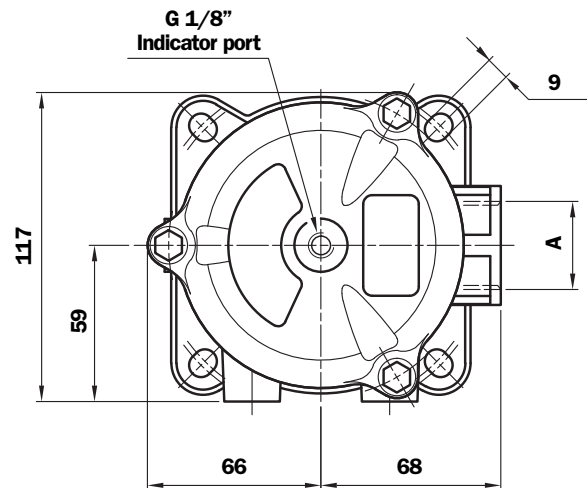
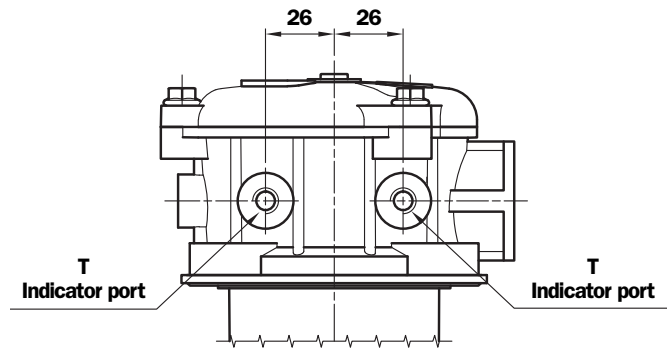
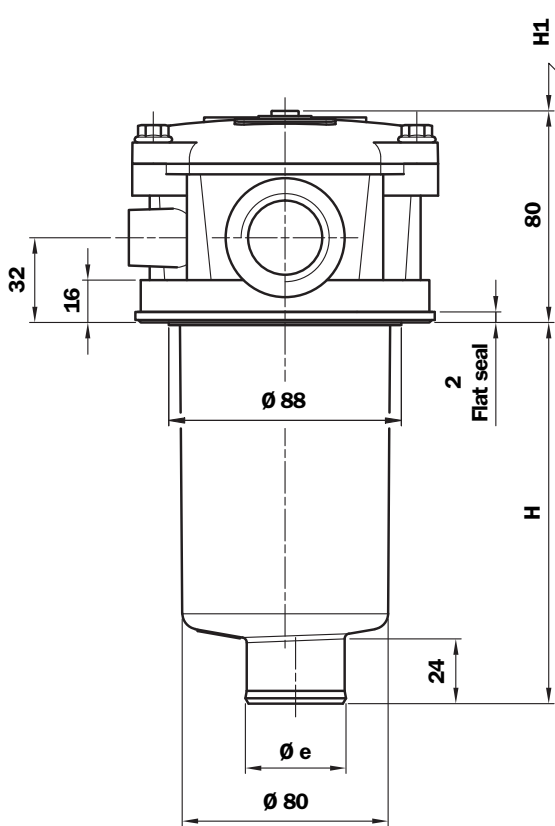

Holes on the tank

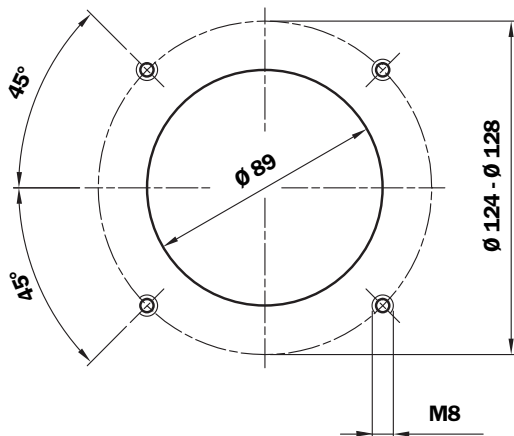

Filter Length	H mm	H1 mm	Ø e mm
1	103	120	38
2	150	170	38
3	228	250	46,5
4	330	350	46,5

Thread connections

Type 1	T	Type 2	T	A
G1	Indicator port not machined	C1	G 1/8"	G 1/2"
G2		C2	G 1/8"	G 3/4"
G3		C3	G 1/8"	G 1"
G4		C4	1/8" NPT	1/2" NPT
G5		C5	1/8" NPT	3/4" NPT
G6		C6	1/8" NPT	1" NPT
G7		C7	1/8" NPT	SAE 8 - 3/4" - 16 UNF
G8		C8	1/8" NPT	SAE 12 - 1 1/16" - 12 UN
G9		C9	1/8" NPT	SAE 16 - 1 5/16" - 12 UN

MPF 110



Multiport
Standard
Single In Port



Multiport
Double In Port
Option: Double Indicator Port



Multiport
Double In Port
Drain Port
Option: Indicator Port



Multiport
Double In Port
Double Drain Port

MPF 110

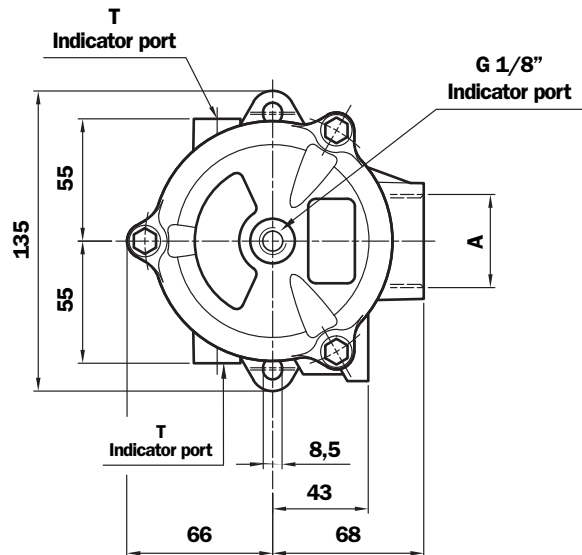
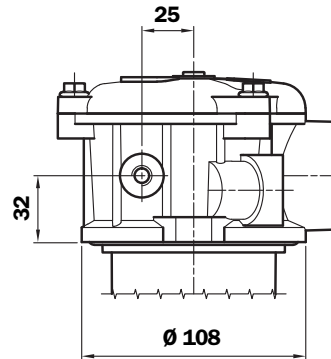
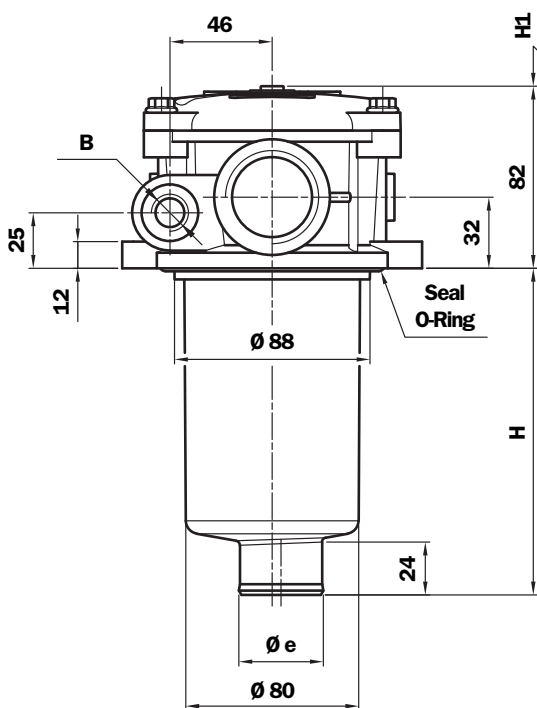

Holes on the tank

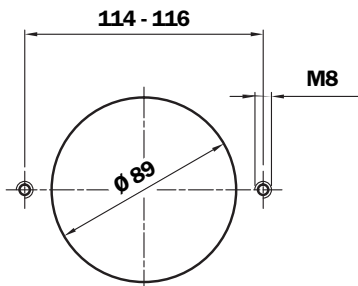

Thread connections A

Type	T	A
G1	G 1/8"	G 1/2"
G2	G 1/8"	G 3/4"
G3	G 1/8"	G 1"
G10	G 1/8"	G 1 1/4"
G4	1/8" NPT	1/2" NPT
G5	1/8" NPT	3/4" NPT
G6	1/8" NPT	1" NPT
G11	1/8" NPT	1 1/4" NPT
G7	1/8" NPT	SAE 8 - 3/4" - 16 UNF
G8	1/8" NPT	SAE 12 - 1 1/16" - 12 UN
G9	1/8" NPT	SAE 16 - 1 5/16" - 12 UN
G12	1/8" NPT	SAE 20 - 1 5/8" - 12 UN

Filter Length	H mm	H1 mm	Ø e mm
1	99	120	38
2	146	170	38
3	224	250	46,5
4	326	350	46,5

T indicator port
G 1/4" - 1/4" NPT
ON REQUEST

Thread connections A	Thread connections B	
	1	2
G1 - G2 - G3 - G10	G 3/8"	G 1/2"
G4 - G5 - G6 - G11	3/8" NPT	1/2" NPT
G7 - G8 - G9 - G12	SAE 8 - 9/16" - 18 UNF	SAE 8 - 3/4" - 16 UNF

MPF 181 - 191



MPF 182 - 192

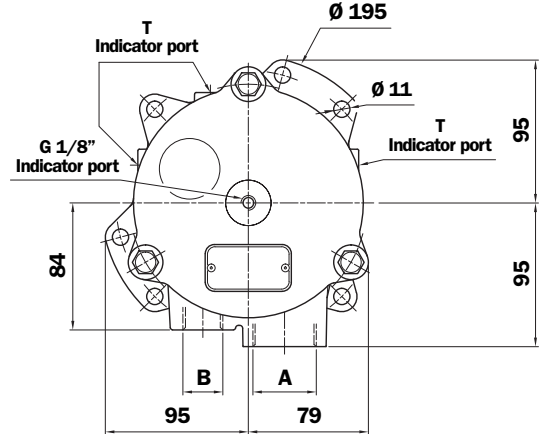
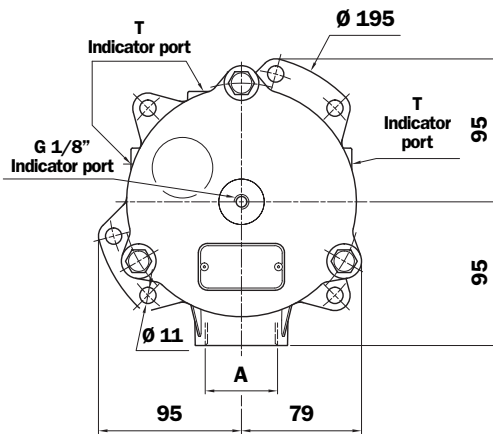
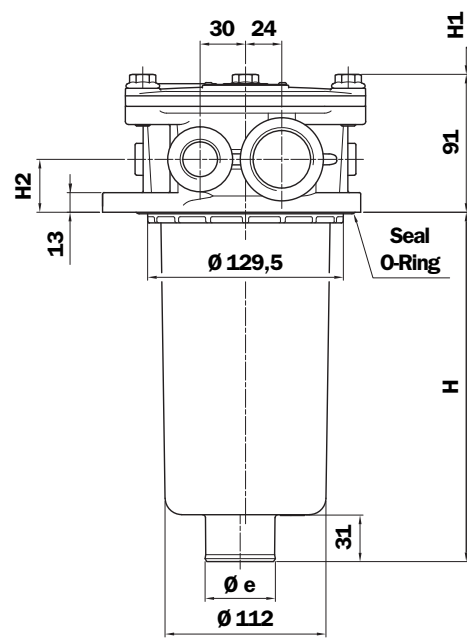
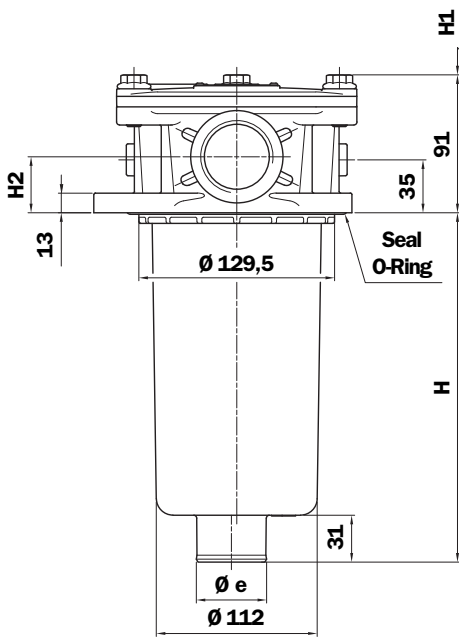

2 option holes on the tank

MPF	Filter Length	H mm	H1 mm	$\varnothing e$ mm
181 - 182	1	233	255	47
	2	445	475	47
191 - 192	2	445	475	50

MPF 181 - 191 Thread connections A

Type 1	T	Type 2	T	A	H2
G1	Indicator port not machined	C1	G 1/8"	G 1 1/4"	35
G4		C4	1/8" NPT	1 1/4" NPT	35
G7		C7	1/8" NPT	SAE 20 - 1 5/8" - 12 UN	35
G2	Indicator port not machined	C2	G 1/8"	G 1 1/2"	37
G5		C5	1/8" NPT	1 1/2" NPT	37
G8		C8	1/8" NPT	SAE 24 - 1 7/8" - 12 UN	37

MPF 182 - 192 Thread connections A

Type 1	T	Type 2	T	A	H2
G1	Ind. port not mach.	C1	G 1/8"	G 1 1/4"	35
G4		C4	1/8" NPT	1 1/4" NPT	35
G7		C7	1/8" NPT	SAE 20 - 1 5/8" - 12 UN	35

3 holes assembly

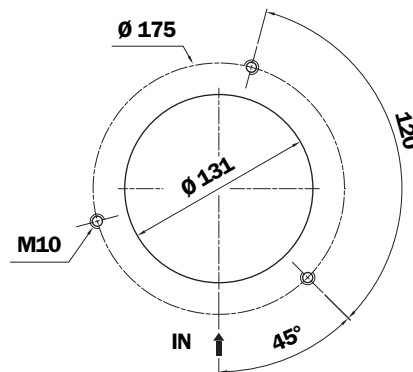

4 holes assembly

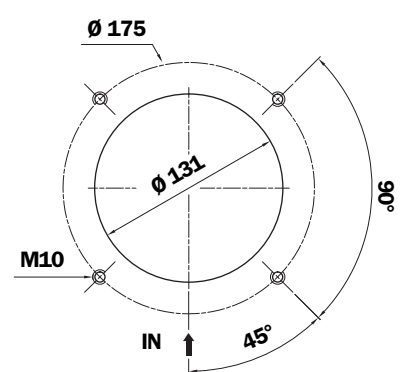

Thread connections A	Thread connections B (only for MPF 182 - 192)	
	1	2
G1 - C1	G 1/2"	G 3/4"
G4 - C4	1/2 NPT	3/4" NPT
G7 - C7	SAE 8 - 3/4" - 16 UNF	SAE 12 - 1 1/16" - 12 UN

T indicator port
G 1/4" - 1/4" NPT
ON REQUEST

MPF 184 - 194

1 connection port



MPF 184 - 194

2 connection port

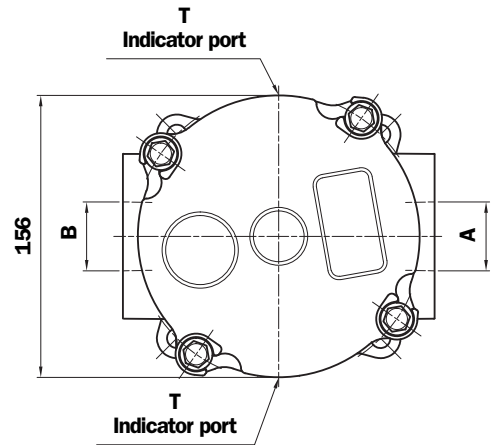
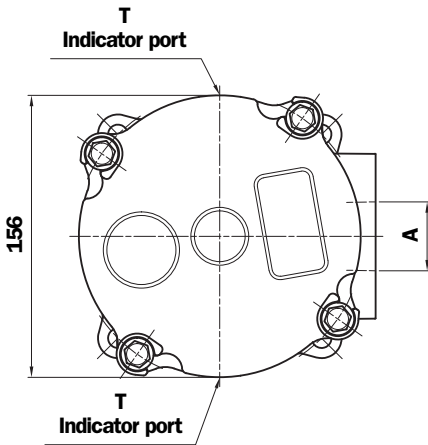
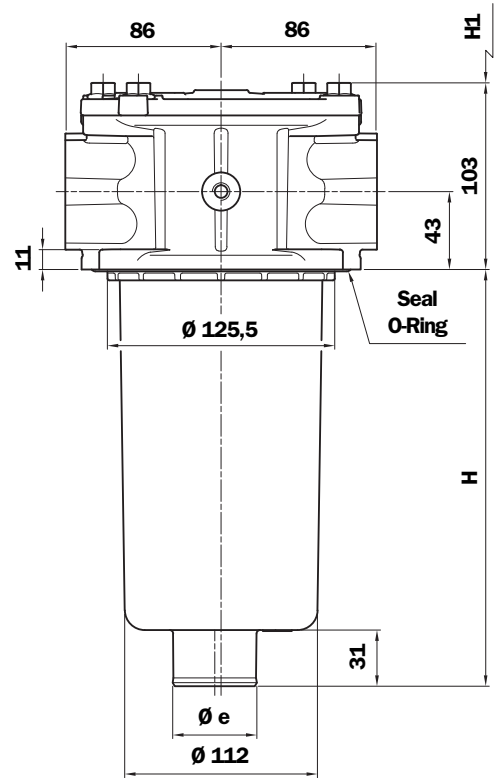
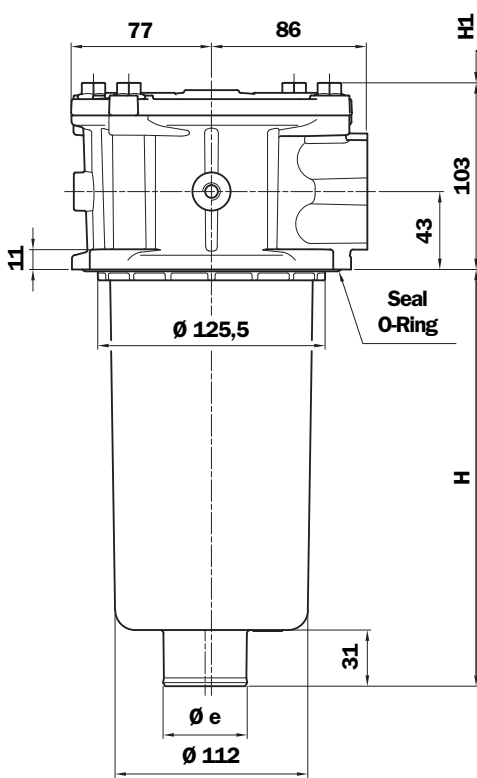

Holes on the tank

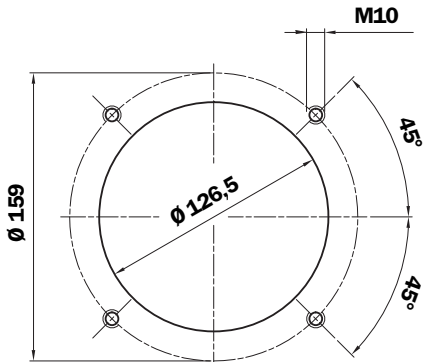

MPF	Filter Length	H mm	H1 mm	Ø e mm
184	1	230	260	47
	2	442	480	47
194	2	441	480	50

Thread connections

Type	A		T
G1	G 1 1/4"	-	G 1/8"
G13	G 1 1/2"	-	G 1/8"
G4	1 1/4" NPT	-	1/8" NPT
G15	1 1/2" NPT	-	1/8" NPT
G7	SAE 20 - 15/8" - 12 UN	-	1/8" NPT
G10	SAE 24 - 17/8" - 12 UN	-	1/8" NPT

Type	A	B	T
G2	G 1 1/4"	G 1 1/4"	G 1/8"
G14	G 1 1/2"	G 1 1/4"	G 1/8"
G5	1 1/4" NPT	1 1/4" NPT	1/8" NPT
G16	1 1/2" NPT	1 1/4" NPT	1/8" NPT
G8	SAE 20 - 15/8" - 12 UN	SAE 20 - 15/8" - 12 UN	1/8" NPT
G11	SAE 24 - 17/8" - 12 UN	SAE 20 - 15/8" - 12 UN	1/8" NPT

Flange connections*

Type	A		T
F1	1 1/2" SAE 3000 psi/M	-	G 1/8"
F2	1 1/2" SAE 3000 psi/UNC	-	1/8" NPT

Type	A	B	T
F3	1 1/2" SAE 3000 psi/M	1 1/2" SAE 3000 psi/M	G 1/8"
F4	1 1/2" SAE 3000 psi/UNC	1 1/2" SAE 3000 psi/UNC	1/8" NPT

*Connections table "DN - SAE flange" see page 5

MPF 400

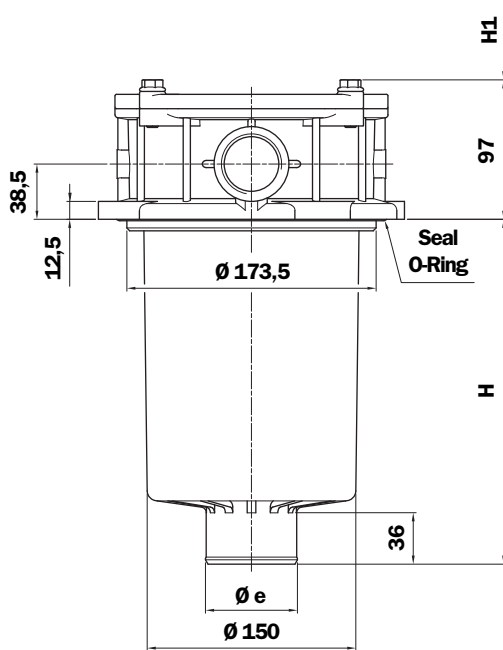

MPF 450 - 451

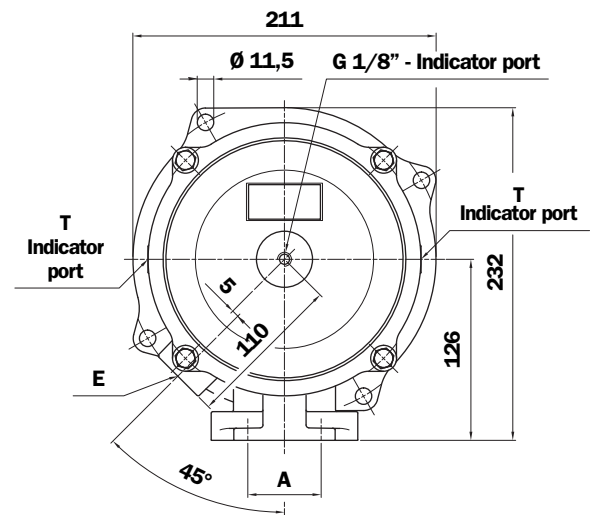
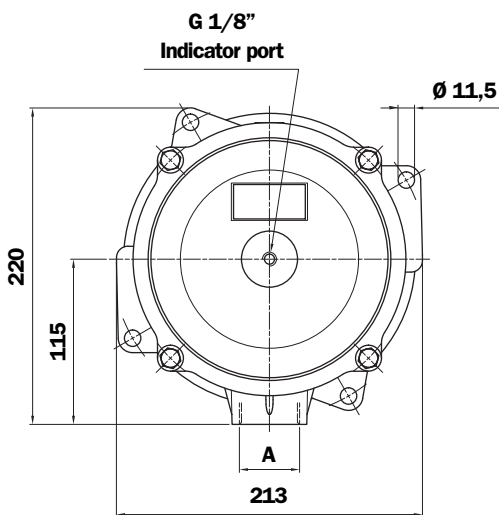
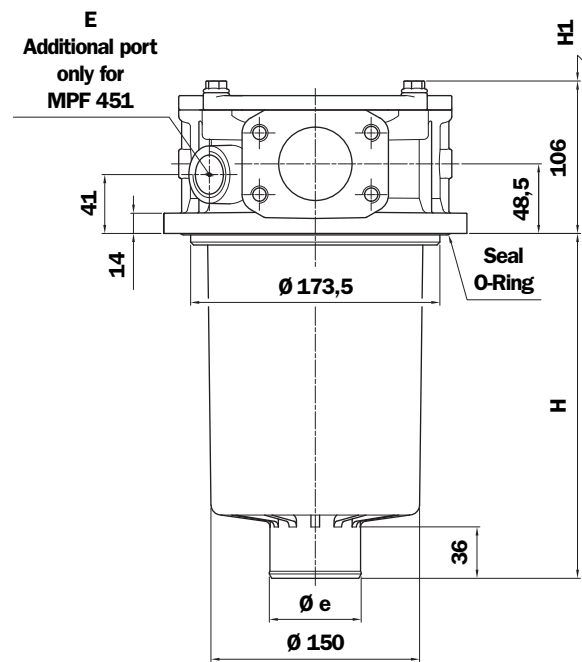

Holes on the tank

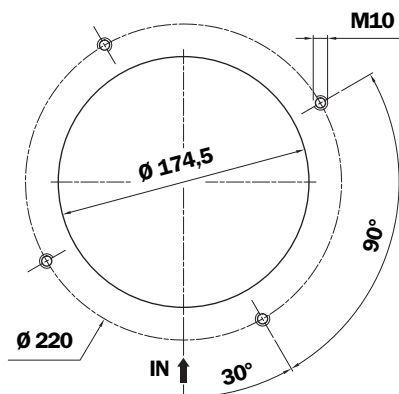

MPF 400

Thread connections

Type	A
G1	G 1 1/4"
G2	G 1 1/2"
G3	G 2"
G4	1 1/4" NPT
G5	1 1/2" NPT
G6	2" NPT
G7	SAE 20 - 1 5/8" - 12 UN
G8	SAE 24 - 1 7/8" - 12 UN
G9	SAE 32 - 2 1/2" - 12 UN

MPF 400 - 450 - 451

Filter Length	H mm	H1 mm	Ø e mm
1	180	210	51
2	240	270	64
3	290	315	64

MPF 450 - 451

Thread connections

Type	A	E ⁽¹⁾	T
G1	G 2"	G 3/4"	G 1/8"
G4	2" NPT	3/4" NPT	1/8" NPT
G7	SAE 32 - 2 1/2" - 12 UN	SAE 12	1/8" NPT

Flange connections MPF 450 - 451⁽²⁾

Type	A	E ⁽¹⁾	T
F1	2" SAE 3000 psi/M	G 3/4"	G 1/8"
F2	2" SAE 3000 psi/UNC	3/4" NPT	1/8" NPT

(1) Additional port only for MPF 451

(2) Connections table "DN - SAE flange" see page 5

MPF 750

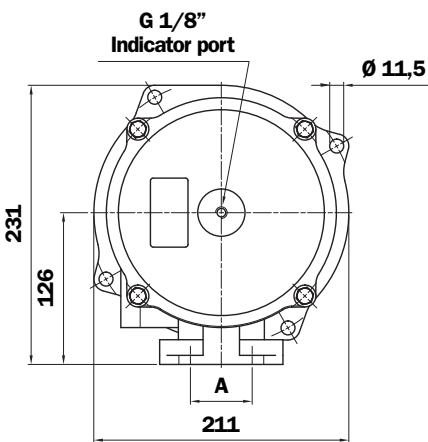
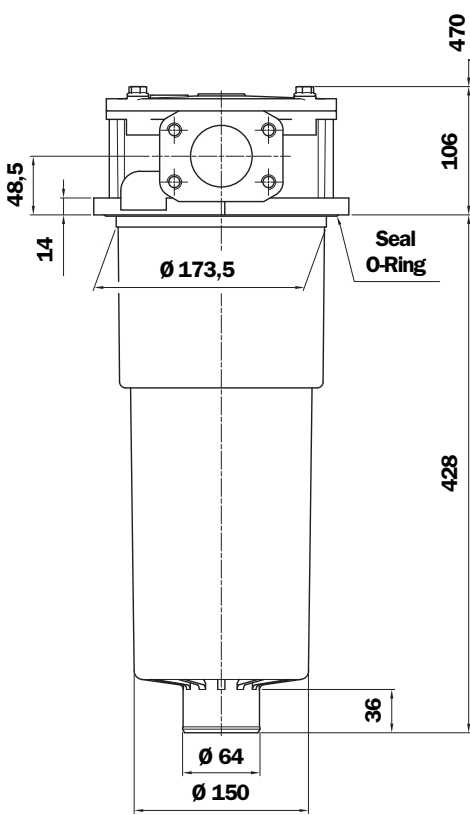

Holes on the tank

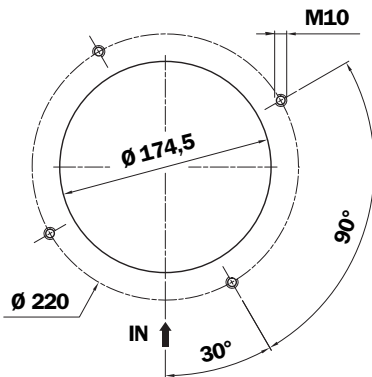

Thread connections

Type	A
G1	G 2"
G4	2" NPT
G7	SAE 32 - 2 1/2" - 12 UN

Flange connections*

Type	A
F1	2" SAE 3000 psi/M
F2	2" SAE 3000 psi/UNC

*Connections table "DN - SAE flange" see page 5

Spare parts

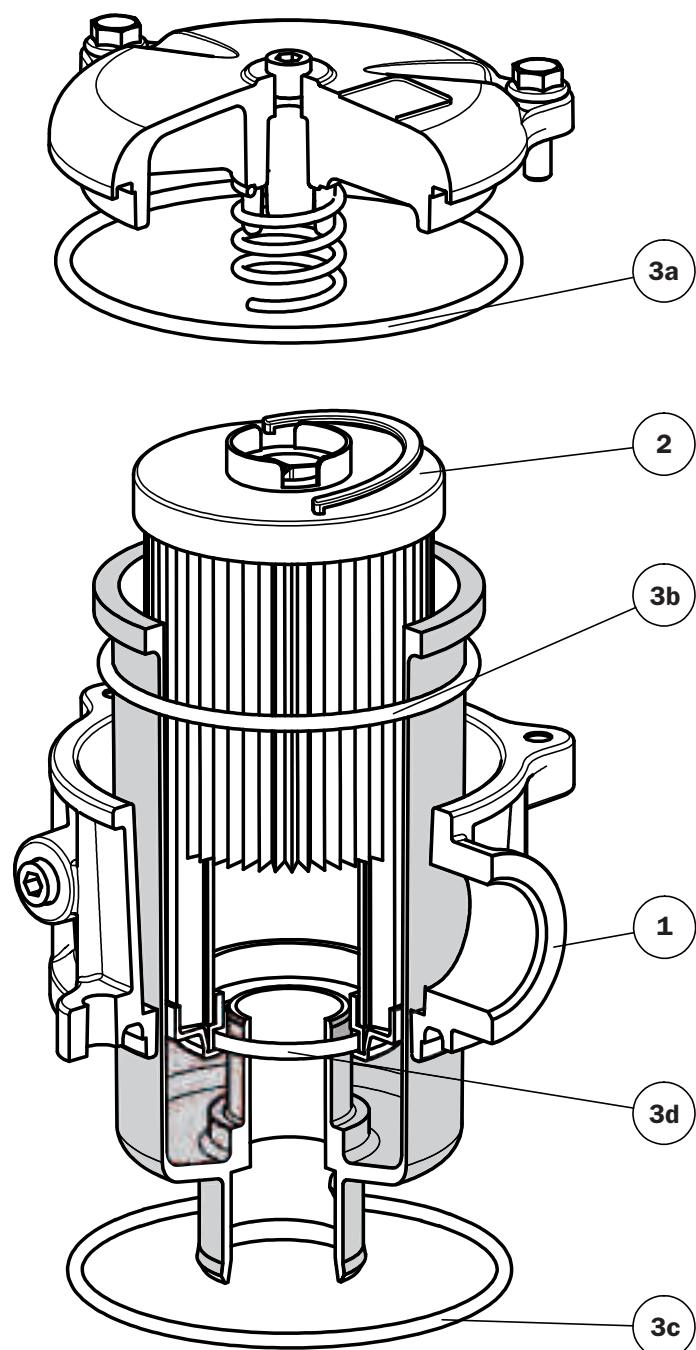

Spare parts

Item	Description	Q.ty	FILTER Series MPF							
			020		030		100 - 110		104	
1	Filter assembly	1	See order table							
2	Filter element	1	See order table							
3	Seal Kit	1	NBR 02050438	FPM 02050439	NBR 02050055	FPM 02050056	NBR 02050057	FPM 02050058	NBR 02050350	FPM 02050408
3a	Cover seal	1	O-R 174 Ø 71,44 x 3,53		O-R 174 Ø 71,44 x 3,53		O-R 4387 Ø 98,02 x 3,53		O-R 4387 Ø 98,02 x 3,53	
3b	Bowl seal	1	-		O-R 3225 Ø 56,82 x 2,62		O-R 4312 Ø 78,97 x 3,53		O-R 4312 Ø 78,97 x 3,53	
3c	Head seal	1	01026335	01026336	O-R 3275 Ø 69,52 x 2,62		O-R 6362 Ø 91,44 x 5,34		01026256	01026286
3d	Filter element seal	1	O-R 3093 Ø 23,47 x 2,62		O-R 3093 Ø 23,47 x 2,62		Length 1-2 O-R 4112 Ø 28,17 x 3,53		Length 1-2 O-R 4112 Ø 28,17 x 3,53	
							Length 3-4 O-R 4162 Ø 40,86 x 3,53		Length 3-4 O-R 4162 Ø 40,86 x 3,53	

Item	Description	Q.ty	FILTER Series MPF							
			181 - 182		184		191 - 192		194	
1	Filter assembly	1	See order table							
2	Filter element	1	See order table							
3	Seal Kit	1	NBR 02050059	FPM 02050060	NBR 02050455	FPM 02050456	NBR 02050457	FPM 02050458	NBR 02050459	FPM 02050460
3a	Cover seal	1	O-R 4537 Ø 136,10 x 3,53		O-R 4512 Ø 129,80 x 3,53		O-R 4537 Ø 136,10 x 3,53		O-R 4512 Ø 129,80 x 3,53	
3b	Bowl seal	1	O-R 4425 Ø 107,50 x 3,53		O-R 4425 Ø 107,50 x 3,53		O-R 4425 Ø 107,50 x 3,53		O-R 4425 Ø 107,50 x 3,53	
3c	Head seal	1	O-R 6535 Ø 135,89 x 5,34		O-R 210 Ø 133,40 x 5,34		O-R 6535 Ø 135,89 x 5,34		O-R 210 Ø 133,40 x 5,34	
3d	Filter element seal	1	O-R 4162 Ø 40,86 x 3,53		O-R 4162 Ø 40,86 x 3,53		O-R Metric Ø 50 x 4		O-R Metric Ø 50 x 4	

Item	Description	Q.ty	FILTER Series MPF					
			400		450 - 451		750	
1	Filter assembly	1	See order table					
2	Filter element	1	See order table					
3	Seal Kit	1	NBR 02050061	FPM 02050062	NBR 02050461	FPM 02050462	NBR 02050106	FPM 02050107
3a	Cover seal	1	O-R 4675 Ø 171 x 3,53		O-R 4675 Ø 171 x 3,53		O-R 4675 Ø 171 x 3,53	
3b	Bowl seal	1	O-R 221 Ø 149,20 x 5,34		O-R 221 Ø 149,20 x 5,34		O-R 221 Ø 149,20 x 5,34	
3c	Head seal	1	O-R 233 Ø 181 x 6,99		O-R 233 Ø 181 x 6,99		O-R 6720 Ø 183,51 x 5,34	
3d	Filter element seal	1	Length 1 O-R 155 Ø 50,80 x 3,53	Length 1 O-R 155 Ø 50,80 x 3,53	Length 1 O-R 155 Ø 50,80 x 3,53	Length 1 O-R 155 Ø 50,80 x 3,53	O-R 168 Ø 65,09 x 3,53	
			Length 2-3 O-R 168 Ø 65,09 x 3,53	Length 2-3 O-R 168 Ø 65,09 x 3,53	Length 2-3 O-R 168 Ø 65,09 x 3,53	Length 2-3 O-R 168 Ø 65,09 x 3,53		

Ordering information MPF 020-030-104

Filter assembly

MPF

	1	2	3	4	5	6	8	9
MPF	<input type="checkbox"/>	<input type="checkbox"/>	<input type="checkbox"/>	<input type="checkbox"/>	<input type="checkbox"/>	<input type="checkbox"/>	<input type="checkbox"/>	<input type="checkbox"/>
Example 1: MPF	104	2	A	G3	A06	H	E	P01
Example 2: MPF	030	1	A	G1	A10	H	B	P01

Filter element

MF

	1	2	5	6	7	8	9
MF	<input type="checkbox"/>	<input type="checkbox"/>	<input type="checkbox"/>	<input type="checkbox"/>	<input type="checkbox"/>	<input type="checkbox"/>	<input type="checkbox"/>
Example 1: MF	100	2	A06	H	B	E	P01
Example 2: MF	030	1	A10	H	B	B	P01

1 - Style

Filter	Filter element
<input type="checkbox"/> 020	<input type="checkbox"/> 030
<input type="checkbox"/> 030	<input type="checkbox"/> 030
<input type="checkbox"/> 104	<input type="checkbox"/> 100

2 - Filter length

<input type="checkbox"/> 020	<input type="checkbox"/> 1				
<input type="checkbox"/> 030	<input type="checkbox"/> 1				
<input type="checkbox"/> 104	<input type="checkbox"/> 1	<input type="checkbox"/> 2	<input type="checkbox"/> 3	<input type="checkbox"/> 4	

3 - Filter seals & Treatment

<input type="checkbox"/> A	NBR
<input type="checkbox"/> V	FPM
<input type="checkbox"/> W*	NBR, head anodized
<input type="checkbox"/> Z*	FPM, head anodized

4 - Connections

MPF 020

Type	A
P1	Hose barb - Ø 12

MPF 030

Type	A
G1	G 1/2"
G4	1/2" NPT
G7	SAE 8 - 3/4" - 16 UNF

MPF 104

Type 1	T	Type 2	T	A
G1	Indicator port not machined	C1	G 1/8"	G 1/2"
G2		C2	G 1/8"	G 3/4"
G3		C3	G 1/8"	G 1"
G4		C4	1/8" NPT	1/2" NPT
G5		C5	1/8" NPT	3/4" NPT
G6		C6	1/8" NPT	1" NPT
G7		C7	1/8" NPT	SAE 8 - 3/4" - 16 UNF
G8		C8	1/8" NPT	SAE 12 - 1 1/16" - 12 UN
G9		C9	1/8" NPT	SAE 16 - 1 5/16" - 12 UN

5 - Filter element

<input type="checkbox"/> A03	Inorganic microfibre 3 µ	Absolute filtration βx(c) ≥ 1000
<input type="checkbox"/> A06	Inorganic microfibre 6 µ	
<input type="checkbox"/> A10	Inorganic microfibre 10 µ	
<input type="checkbox"/> A16	Inorganic microfibre 16 µ	
<input type="checkbox"/> A25	Inorganic microfibre 25 µ	
<input type="checkbox"/> M25	Wire mesh	Nominal Filtration
<input type="checkbox"/> M60	Wire mesh	
<input type="checkbox"/> M90	Wire mesh	
<input type="checkbox"/> P10	Resin impregnated paper	Nominal Filtration
<input type="checkbox"/> P25	Resin impregnated paper	

6 - Δp Filter element

<input type="checkbox"/> N	Δp 10 bar (only for filter element type Pxx and Mxx)
<input type="checkbox"/> H	Δp 10 bar (only for filter element type Axx)
<input type="checkbox"/> W*	Δp 10 bar (only for filter element type Axx and Mxx)

7 - Filter element seals

<input type="checkbox"/> B	NBR
<input type="checkbox"/> V	FPM

8 - By-pass valve

<input type="checkbox"/> E	3 bar
<input type="checkbox"/> B	1.75 bar (Omit in the element code - only for 1.75 bar)

9 - Option

<input type="checkbox"/> P01	MP Filtri standard
------------------------------	--------------------

* Compatible with fluid HFA, HFB, HFC

MP Filtri - The filter functions as described in this bulletin are valid exclusively for original MP Filtri filter elements and replacement parts. All rights reserved

The data in this publication are purely guideline. MP Filtri reserves the right to make changes to the models described herein at any time it deems fit in relation to technical or commercial requirements. The colours of the products shown on the cover are purely guideline. Copyright. All rights reserved.

Ordering information MPF 100-110

Filter assembly

MPF

	1	2	3	4	5	6	7	9	10
Example 1: MPF	110	2	A	G3	1	A06	H	E	P01
Example 2: MPF	100	1	W	G1		A10	W	B	P01

Filter element

MF

	1	2	6	7	8	9	10
Example 1: MF	100	2	A06	H	B	E	P01
Example 2: MF	100	1	A10	W	B		P01

1 - Style

Filter	Filter element
100	100
110	100

2 - Filter length

100	1	2	3	4
110	1	2	3	4

3 - Filter seals & Treatment

A	NBR
V	FPM
W*	NBR, head anodized
Z*	FPM, head anodized

4 - Connections A

MPF 100

Type 1	T	Type 2	T	A
G1	Indicator port not machined	C1	G 1/8"	G 1/2"
G2		C2	G 1/8"	G 3/4"
G3		C3	G 1/8"	G 1"
G10		C10	G 1/8"	G 1 1/4"
G4		C4	1/8" NPT	1/2" NPT
G5		C5	1/8" NPT	3/4" NPT
G6		C6	1/8" NPT	1" NPT
G11		C11	1/8" NPT	1 1/4" NPT
G7		C7	1/8" NPT	SAE 8 - 3/4" - 16 UNF
G8		C8	1/8" NPT	SAE 12 - 1 1/16" - 12 UN
G9		C9	1/8" NPT	SAE 16 - 1 5/16" - 12 UN
G12		C12	1/8" NPT	SAE 20 - 1 5/8" - 12 UN

MPF 110

Type	T	A
G1	G 1/8"	G 1/2"
G2	G 1/8"	G 3/4"
G3	G 1/8"	G 1"
G10	G 1/8"	G 1 1/4"
G4	1/8" NPT	1/2" NPT
G5	1/8" NPT	3/4" NPT
G6	1/8" NPT	1" NPT
G11	1/8" NPT	1 1/4" NPT
G7	1/8" NPT	SAE 8 - 3/4" - 16 UNF
G8	1/8" NPT	SAE 12 - 1 1/16" - 12 UN
G9	1/8" NPT	SAE 16 - 1 5/16" - 12 UN
G12	1/8" NPT	SAE 20 - 1 5/8" - 12 UN

5 - Connections B (only for MPF 110)

Type	Connections A		
	G1 - G2 - G3 - G10	G4 - G5 - G6 - G11	G7 - G8 - G9 - G12
1	G 3/8"	3/8" NPT	SAE 6 - 9/16" 18 UNF
2	G 1/2"	1/2" NPT	SAE 8 - 3/4" 16 UNF

6 - Filter element

A03	Inorganic microfibre 3 µ	Absolute filtration βx (c) ≥ 1000
A06	Inorganic microfibre 6 µ	
A10	Inorganic microfibre 10 µ	
A16	Inorganic microfibre 16 µ	
A25	Inorganic microfibre 25 µ	
M25	Wire mesh	Nominal Filtration
M60	Wire mesh	
M90	Wire mesh	
P10	Resin impregnated paper	Nominal Filtration
P25	Resin impregnated paper	

7 - Δp Filter element

N	Δp 10 bar (only for filter element type Pxx and Mxx)
H	Δp 10 bar (only for filter element type Axx)
W*	Δp 10 bar (only for filter element type Axx and Mxx)

8 - Filter element seals

B	NBR
V	FPM

9 - By-pass valve

E	3 bar
B	1.75 bar (Omit in the element code - only for 1.75 bar)

10 - Option

P01	MP Filtri standard
------------	--------------------

* Compatible with fluid HFA, HFB, HFC

MP Filtri - The filter functions as described in this bulletin are valid exclusively for original MP Filtri filter elements and replacement parts. All rights reserved

The data in this publication are purely guideline. MP Filtri reserves the right to make changes to the models described herein at any time it deems fit in relation to technical or commercial requirements. The colours of the products shown on the cover are purely guideline. Copyright. All rights reserved.

Ordering information NEW MPF 181-182-191-192

Filter assembly	1	2	3	4	5	6	7	9	10 a
MPF	<input type="checkbox"/>	<input type="checkbox"/>	<input type="checkbox"/>	<input type="checkbox"/>	<input type="checkbox"/>	<input type="checkbox"/>	<input type="checkbox"/>	<input type="checkbox"/>	<input type="checkbox"/>
Example 1: MPF	181	1	A	G2		A06	H	E	P01
Example 2: MPF	192	2	A	G1	2	P10	N	B	P01

Filter element	1	2	6	7	8	9	10 b
MF	<input type="checkbox"/>	<input type="checkbox"/>	<input type="checkbox"/>	<input type="checkbox"/>	<input type="checkbox"/>	<input type="checkbox"/>	<input type="checkbox"/>
Example 1: MF	180	1	A06	H	B	E	P01
Example 2: MF	190	2	P10	N	B		P01

1 - Style

Filter	Filter element
<input type="checkbox"/> 181	<input type="checkbox"/> 180
<input type="checkbox"/> 182	<input type="checkbox"/> 180
<input type="checkbox"/> 191	<input type="checkbox"/> 190
<input type="checkbox"/> 192	<input type="checkbox"/> 190

2 - Filter length

<input type="checkbox"/> 181	<input type="checkbox"/> 1	<input type="checkbox"/> 2
<input type="checkbox"/> 182	<input type="checkbox"/> 1	<input type="checkbox"/> 2
<input type="checkbox"/> 191		<input type="checkbox"/> 2
<input type="checkbox"/> 192		<input type="checkbox"/> 2

3 - Filter seals & Treatment

<input type="checkbox"/> A	NBR
<input type="checkbox"/> V	FPM
<input type="checkbox"/> W*	NBR, head anodized
<input type="checkbox"/> Z*	FPM, head anodized
<input type="checkbox"/> B	NBR, flat seal on head
<input type="checkbox"/> D	FPM, flat seal on head
<input type="checkbox"/> L	NBR, flat seal on head, head anodized
<input type="checkbox"/> M	FPM, flat seal on head, head anodized

4 - Connections A

MPF 181 - 191

Type 1	T	Type 2	T	A
G1	Indicator port not machined	C1	G 1/8"	G 1 1/4"
G4		C4	1/8" NPT	1 1/4" NPT
G7		C7	1/8" NPT	SAE 20 - 15/8" - 12 UN
G2		C2	G 1/8"	G 1 1/2"
G5		C5	1/8" NPT	1 1/2" NPT
G8		C8	1/8" NPT	SAE 24 - 17/8" - 12 UN

MPF 182 - 192

Type 1	T	Type 2	T	A
G1	Ind. port not mach.	C1	G 1/8"	G 1 1/4"
G4		C4	1/8" NPT	1 1/4" NPT
G7		C7	1/8" NPT	SAE 20 - 15/8" - 12 UN

5 - Connections B (only for MPF 182 - 192)

Type	Connections A		
	G1 - C1	G4 - C4	G7 - C7
1	G 1/2"	1/2" NPT	SAE 8 - 3/4" - 18 UNF
2	G 3/4"	3/4" NPT	SAE 12 - 11/16" - 12 UN

6 - Filter element

<input type="checkbox"/> A03	Inorganic microfibre 3 µ	} Absolute filtration β _x (c) ≥ 1000
<input type="checkbox"/> A06	Inorganic microfibre 6 µ	
<input type="checkbox"/> A10	Inorganic microfibre 10 µ	
<input type="checkbox"/> A16	Inorganic microfibre 16 µ	
<input type="checkbox"/> A25	Inorganic microfibre 25 µ	
<input type="checkbox"/> M25	Wire mesh	} Nominal Filtration
<input type="checkbox"/> M60	Wire mesh	
<input type="checkbox"/> M90	Wire mesh	
<input type="checkbox"/> P10	Resin impregnated paper	} Nominal Filtration
<input type="checkbox"/> P25	Resin impregnated paper	

7 - Δp Filter element

<input type="checkbox"/> N	Δp 10 bar (only for filter element type Pxx and Mxx)
<input type="checkbox"/> H	Δp 10 bar (only for filter element type Axx)
<input type="checkbox"/> W*	Δp 10 bar (only for filter element type Axx and Mxx)

8 - Filter element seals

<input type="checkbox"/> B	NBR
<input type="checkbox"/> V	FPM

9 - By-pass valve

<input type="checkbox"/> E	3 bar
<input type="checkbox"/> B	1.75 bar (Omit in the element code - only for 1.75 bar)

10 - Option

a) Filter	
<input type="checkbox"/> P01	MP Filtri standard
<input type="checkbox"/> Sxx	Filter assembly with steel extension tube mounted (only for MPF 191-192)
b) Filter element	
<input type="checkbox"/> P01	MP Filtri standard

* Compatible with fluid HFA, HFB, HFC

MP Filtri - The filter functions as described in this bulletin are valid exclusively for original MP Filtri filter elements and replacement parts. All rights reserved

The data in this publication are purely guideline. MP Filtri reserves the right to make changes to the models described herein at any time it deems fit in relation to technical or commercial requirements. The colours of the products shown on the cover are purely guideline. Copyright. All rights reserved.

Ordering information MPF 184-194-400-750

Filter assembly

MPF

	1	2	3	4	5	6	8	9a
Example 1: MPF	184	2	A	G2	A06	H	E	P01
Example 2: MPF	750	1	A	G4	P10	N	B	P01

Filter element

MF

	1	2	5	6	7	8	9b
Example 1: MF	180	2	A06	H	B	E	P01
Example 2: MF	750	1	P10	N	B		P01

1 - Style

Filter	Filter element
184	180
194	190
400 450 451	400
750	750

2 - Filter length

184	1	2
194		2
400 450 451	1	2 3
750	1	

3 - Filter seals & Treatment

A	NBR
V	FPM
W*	NBR, head anodized
Z*	FPM, head anodized

4 - Connections

MPF 184 - 194

Type	A	B
G1	G 1 1/4"	-
G13	G 1 1/2"	-
G4	1 1/4" NPT	-
G15	1 1/2" NPT	-
G7	SAE 20 - 1 5/8" - 12 UN	-
G10	SAE 24 - 1 7/8" - 12 UN	-
G2	G 1 1/4"	G 1 1/4"
G14	G 1 1/2"	G 1 1/4"
G5	1 1/4" NPT	1 1/4" NPT
G16	1 1/2" NPT	1 1/4" NPT
G8	SAE 20 - 1 5/8" - 12 UN	SAE 20 - 1 5/8" - 12 UN
G11	SAE 24 - 1 7/8" - 12 UN	SAE 20 - 1 5/8" - 12 UN
F1	1 1/2" SAE 3000 psi/M	-
F2	1 1/2" SAE 3000 psi/UNC	-
F3	1 1/2" SAE 3000 psi/M	1 1/2" SAE 3000 psi/M
F4	1 1/2" SAE 3000 psi/UNC	1 1/2" SAE 3000 psi/UNC

MPF 400

Type	A	Type	A
G1	G 1 1/4"	G6	2" NPT
G2	G 1 1/2"	G7	SAE 20 - 1 5/8" - 12 UN
G3	G 2"	G8	SAE 24 - 1 7/8" - 12 UN
G4	1 1/4" NPT	G9	SAE 32 - 2 1/2" - 12 UN
G5	1 1/2" NPT	-	-

MPF 450 - 451 - 750

Type	A	E(1)
G1	G 2"	G 3/4"
G4	2" NPT	3/4" NPT
G7	SAE 32 - 2 1/2" - 12 UN	SAE 12
F1	2" SAE 3000 psi/M	G 3/4"
F2	2" SAE 3000 psi/UNC	3/4" NPT

(1) Additional port only for MPF 451

5 - Filter element

A03	Inorganic microfibre	3 μ	Absolute filtration βx (c) ≥ 1000
A06	Inorganic microfibre	6 μ	
A10	Inorganic microfibre	10 μ	
A16	Inorganic microfibre	16 μ	
A25	Inorganic microfibre	25 μ	
M25	Wire mesh		Nominal Filtration
M60	Wire mesh		
M90	Wire mesh		
P10	Resin impregnated paper		Nominal Filtration
P25	Resin impregnated paper		

6 - Δp Filter element

N	Δp 10 bar (only for filter element type Pxx and Mxx)
H	Δp 10 bar (only for filter element type Axx)
W*	Δp 10 bar (only for filter element type Axx and Mxx)

7 - Filter element seals

B	NBR
V	FPM

8 - By-pass valve

E	3 bar
B	1.75 bar (Omit in the element code - only for 1.75 bar)

9 - Option

a) Filter	
P01	MP Filtri standard
Sxx	Filter assembly with steel extension tube mounted (only for MPF 194-400-450-451-750)
b) Filter element	
P01	MP Filtri standard

* Compatible with fluid HFA, HFB, HFC

MP Filtri - The filter functions as described in this bulletin are valid exclusively for original MP Filtri filter elements and replacement parts. All rights reserved

The data in this publication are purely guideline. MP Filtri reserves the right to make changes to the models described herein at any time it deems fit in relation to technical or commercial requirements. The colours of the products shown on the cover are purely guideline. Copyright. All rights reserved.

MPH



Maximum pressure 10 bar
Flow rates to 3000 l/min

Filter housing (Materials)

- Head: Aluminium: MPH 104-110-114-120-250
Anodised Aluminium: MPH 630-850
Painted Aluminium: MPH 660
- Cover: Nylon: MPH 104-110-114-120
Aluminium: MPH 250
Anodised Aluminium: MPH 630
Painted Aluminium: MPH 660
Steel: MPH 850
- Insert assembly: Nylon (only for: MPH 104-110-114-120)
Aluminium (all the other)
- Diffuser: Zinc Plated Steel (excluded MPH 850)
Tinned Steel: MPH 850
- Valve: Phosphated Steel

Pressure

- Working pressure: 10 bar

Temperature

- From -25 °C to +110 °C

Bypass valve

- Opening pressure 1,75 bar ±10%
- Opening pressure 2,5 bar ±10% (excluded for MPH 850)

Δp Elements type

- Series MR elements: 10 bar
- Oil flow from inside to outside.

Seals

- Standard NBR series A
- Optional FPM series V

MPH FILTERS ARE PROVIDED FOR VERTICAL MOUNTING

Weights (kg)

Length	1	2	3	4	5
• MPH 104-110	1,60	1,70	1,80	2,20	2,60
• MPH 114-120	1,60	1,70	1,80	2,20	2,60
• MPH 250	3,60	3,90	4,20	5,60	-
• MPH 630	6,50	7,00	7,40	8,50	10,50
• MPH 660	-	-	-	11,5	14
• MPH 850	32	35	38	42	-

Volumes (dm³)

Length	1	2	3	4	5
• MPH 104-110	1,60	1,70	1,80	2,20	2,60
• MPH 114-120	1,60	1,70	1,80	2,20	2,60
• MPH 250	4,40	4,40	5,40	8,00	-
• MPH 630	7,30	9,00	11,0	13	19,2
• MPH 660	-	-	-	14,6	21
• MPH 850	13	16,5	21	25	-

Compatibility (to ISO 2943)

- Housings/Diffuser compatible with:
Mineral oils, synthetic fluids.
Aqueous emulsions, water and glycol (series W required).
- The filter elements are compatible with:
Mineral oils, synthetic fluids.
Aqueous emulsions, water and glycol (series W required).
- NBR seals series A, compatible with:
Mineral oils, synthetic fluids.
Aqueous emulsions, water and glycol.
- FPM seals V series, compatible with:
Synthetic fluids type HS-HFDR-HFDS-HFDU

Filter housings Δp pressure drop

The curves are plotted utilising mineral oil with density of 0.86 kg/dm³ to ISO 3968.

Δp varies proportionally with density.

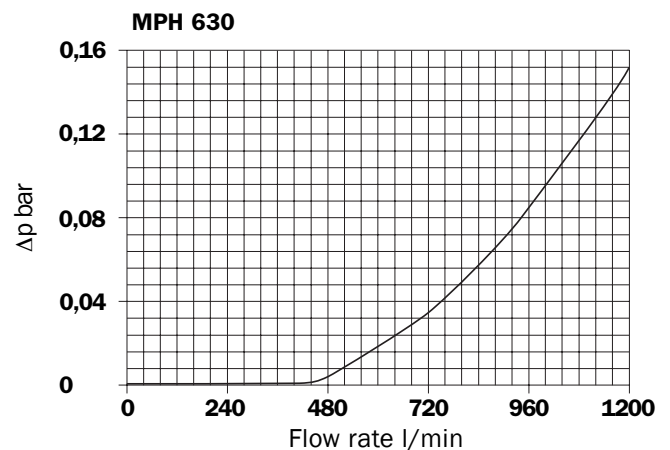
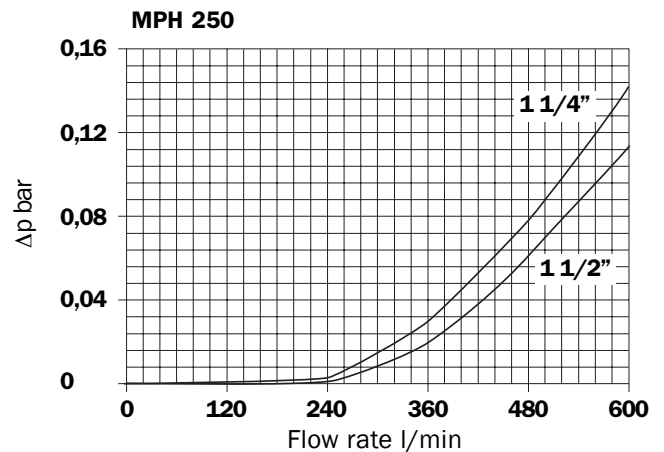
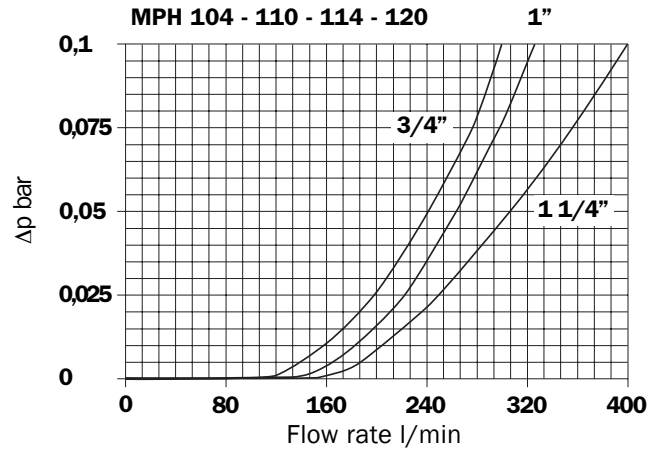

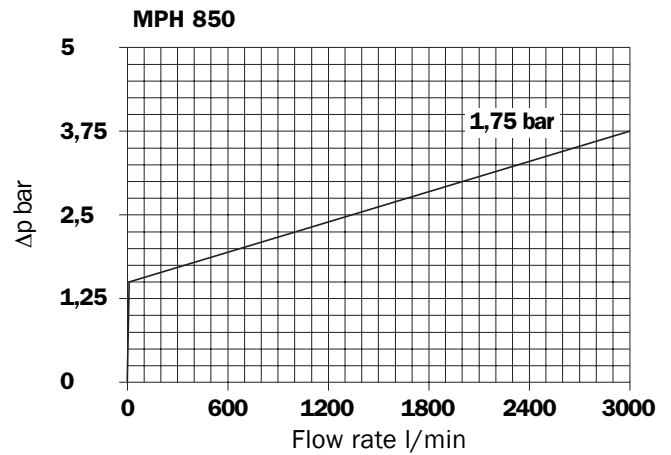
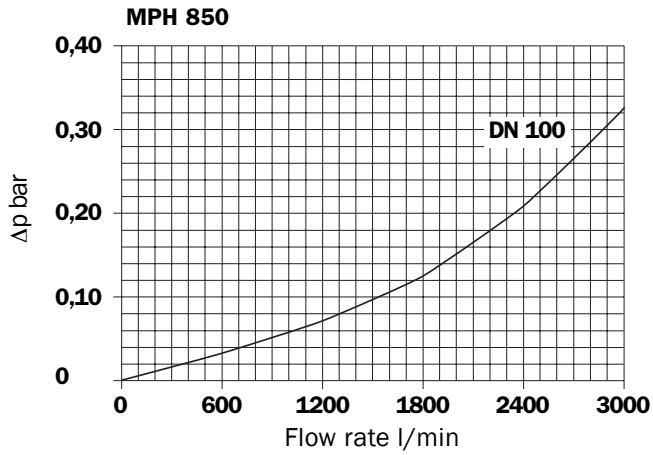
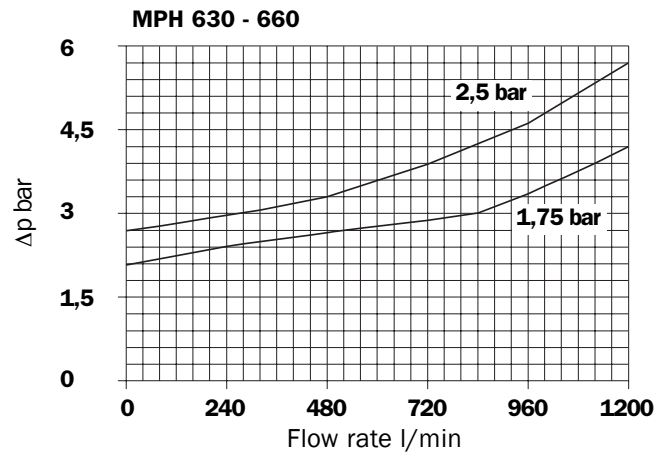
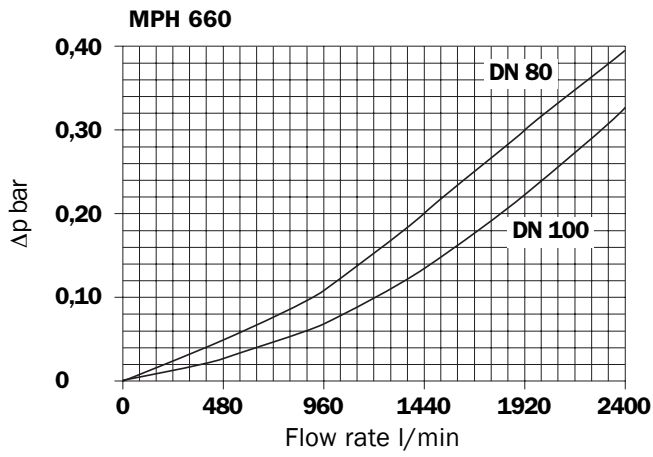

Valves

Bypass valve pressure drop

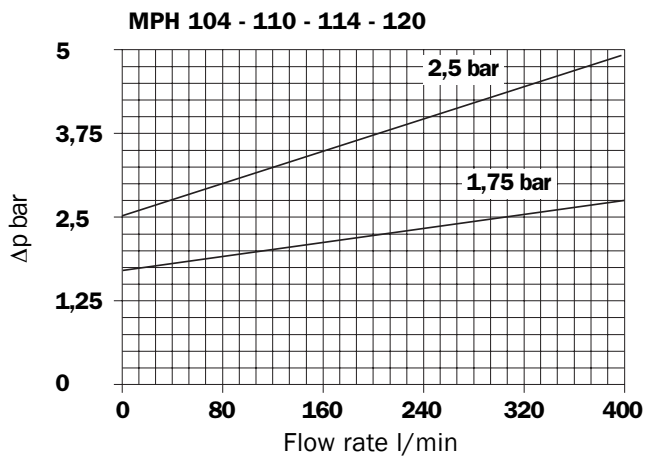

Air breather

Pressure drop

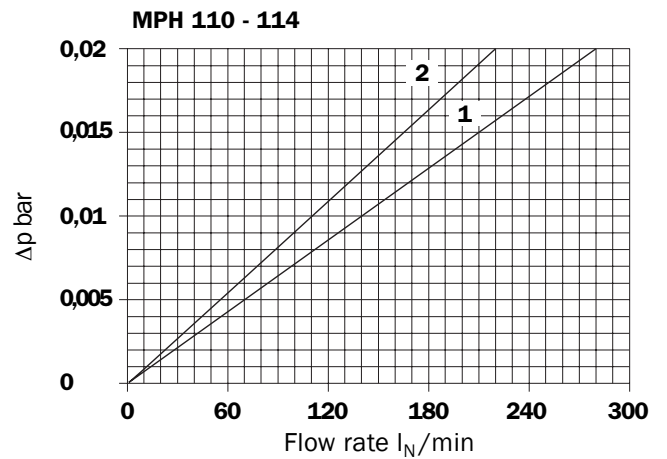

- 1: C With air breather 10 μ
- 2: D With anti-splash and SAP50 10 μ

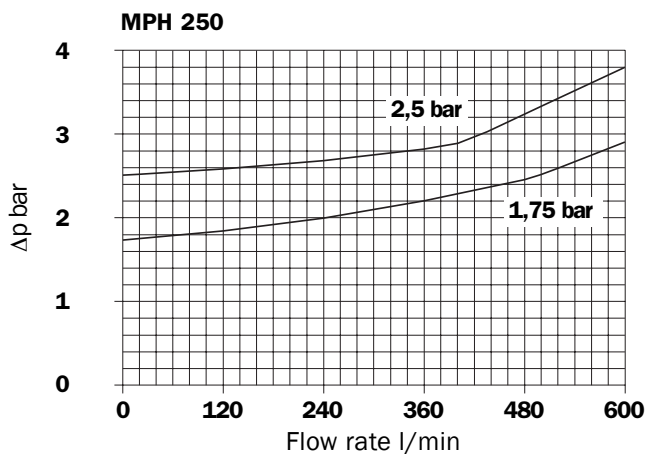

Recommended maximum flow rate

- Pressure drop of filter assembly equal to Δp 0,5 bar.
- Oil kinematic viscosity 30 mm²/s (cSt).
- Density 0,86 kg/dm³.

Filtration

	Length	A03	A06	A10	A16	A25	P10	P25	M25 - M60 - M90
MPH 104-110 114-120	1	26	29	72	80	106	160	185	280
	2	42	45	110	115	160	164	187	300
	3	63	72	130	155	175	215	245	300
	4	89	98	180	198	215	265	300	300
	5	115	125	200	218	240	280	300	300
MPH 250	1	92	100	205	245	300	330	370	700
	2	120	145	310	410	420	462	517	700
	3	185	215	415	440	500	550	616	700
	4	255	295	550	615	750	825	700	700
MPH 630	1	160	198	360	410	510	561	628	1200
	2	235	250	555	600	1025	1128	1200	1200
	3	325	370	730	770	1200	1200	1200	1200
	4	370	400	870	990	1200	1200	1200	1200
	5	610	690	1180	1200	1200	1200	1200	1200
MPH 660	4	370	400	890	1030	1400	1540	1700	1700
	5	620	699	1280	1340	1700	1700	1700	1700
MPH 850	1	770	1030	1240	1550	2230	2600	2650	3000
	2	1170	1520	1680	1740	2440	2684	2900	3000
	3	1480	1910	1990	2010	3000	3000	3000	3000
	4	1660	2080	2300	2360	3000	3000	3000	3000

Flow rate l/min

Dimensions

MPH 104 Without air breather

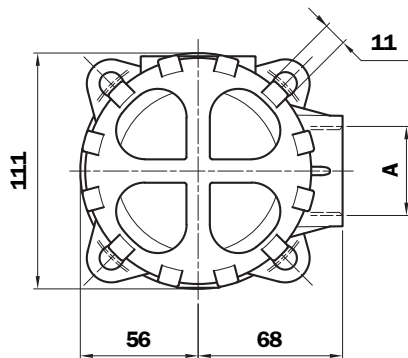
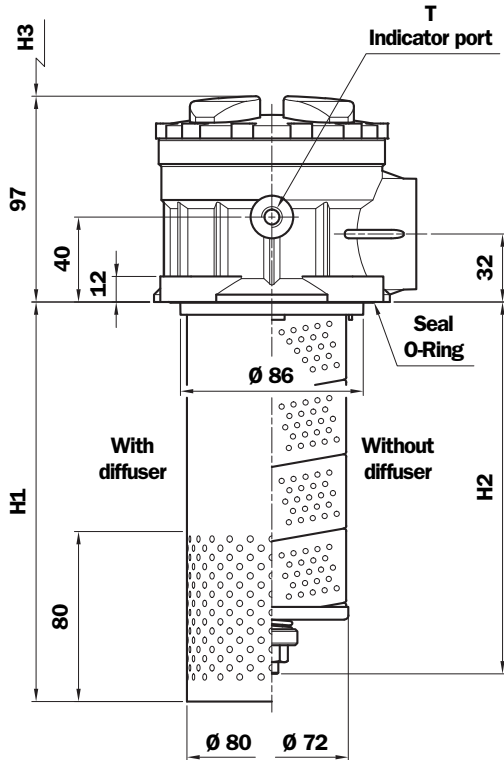

Holes on the tank

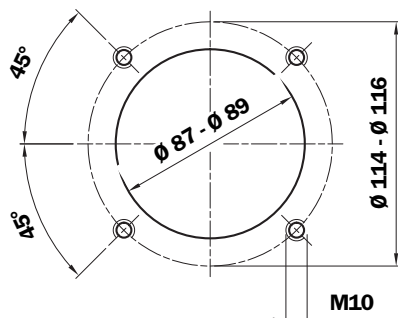

Thread connections

Type	A	T
G1	G 3/4"	G 1/8"
G2	G 1"	G 1/8"
G3	G 1 1/4"	G 1/8"
G4	3/4" NPT	1/8" NPT
G5	1" NPT	1/8" NPT
G6	1 1/4" NPT	1/8" NPT
G7	SAE 12 - 1 1/6" - 12 UN	1/8" NPT
G8	SAE 16 - 1 5/16" - 12 UN	1/8" NPT
G9	SAE 20 - 1 5/8" - 12 UN	1/8" NPT

Filter Length	H1 mm	H2 mm	H3 mm
1	190	131	255
2	190	175	255
3	240	225	305
4	340	325	405
5	440	425	505

MPH 110

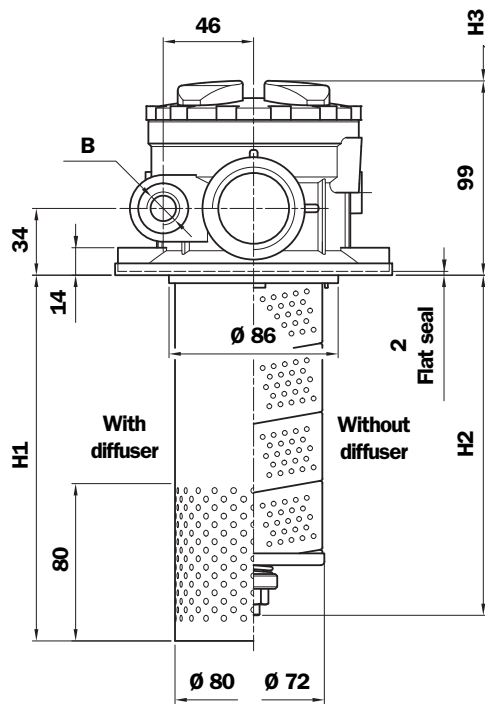

Version "S"
Without air breather

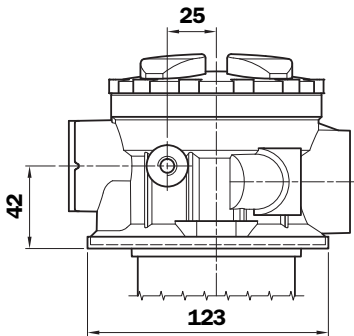

Version "C"
With air breather

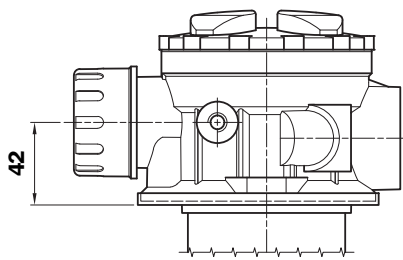

Version "D" and "P"
Anti-splash and SAP50

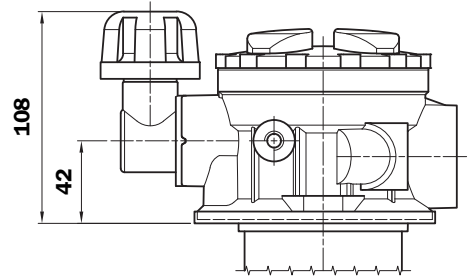

T Indicator port

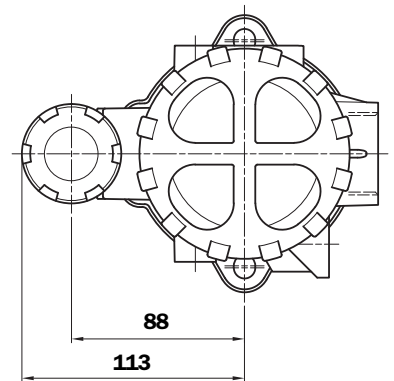
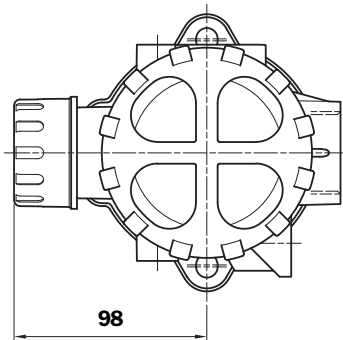
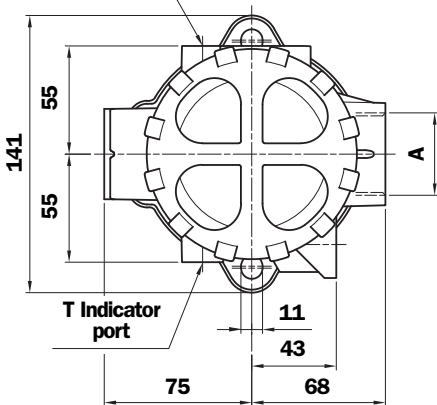

T indicator port
G 1/4" - 1/4" NPT
ON REQUEST

Holes on the tank

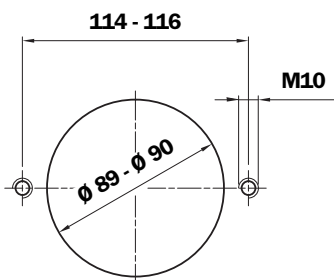

Thread connections A

Type	A	T
G1	G 3/4"	G 1/8"
G2	G 1"	G 1/8"
G3	G 1 1/4"	G 1/8"
G4	3/4" NPT	1/8" NPT
G5	1" NPT	1/8" NPT
G6	1 1/4" NPT	1/8" NPT
G7	SAE 12 - 1 1/16" - 12 UN	1/8" NPT
G8	SAE 16 - 1 5/16" - 12 UN	1/8" NPT
G9	SAE 20 - 1 5/8" - 12 UN	1/8" NPT

Filter Length	H1 mm	H2 mm	H3 mm
1	188	129	255
2	188	173	255
3	238	223	305
4	338	323	405
5	438	423	505

Thread connections A	Thread connections B		
	0	1	2
G1 - G2 - G3	not machined	G 3/8"	G 1/2"
G4 - G5 - G6	not machined	3/8" NPT	1/2" NPT
G7 - G8 - G9	not machined	SAE 6 - 9/16" - 18 UNF	SAE 8 - 3/4" - 16 UNF

MPH 114

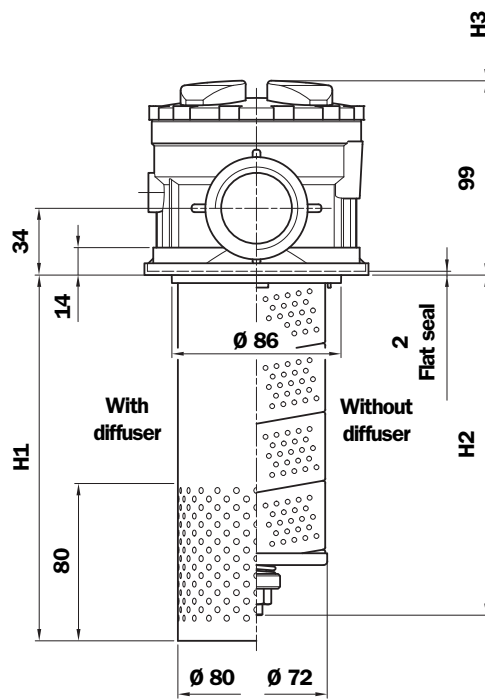

Version "S"
Without air breather

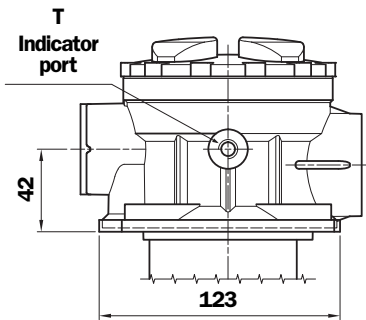

Version "C"
With air breather

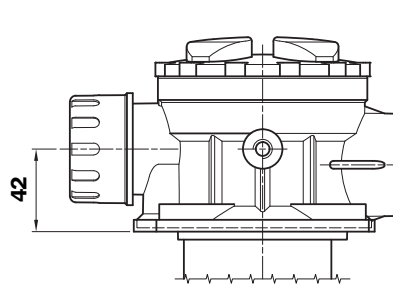

Version "D" and "P"
Anti-splash and SAP50

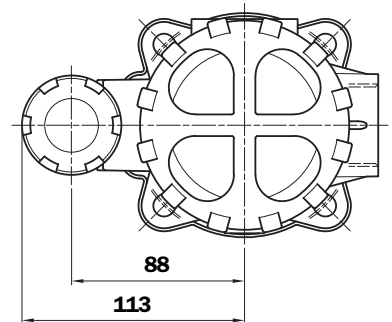
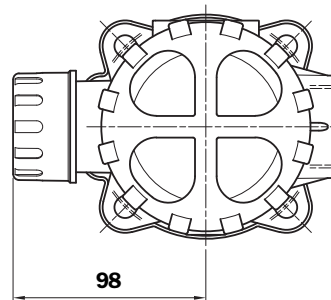
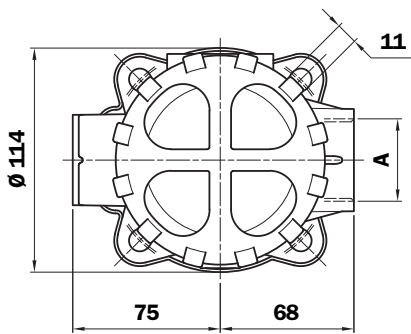
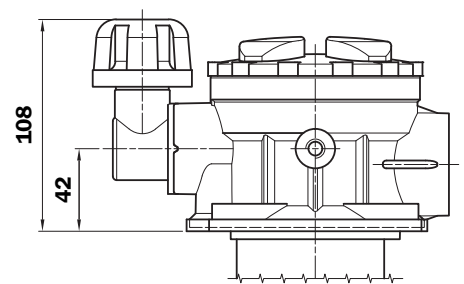

Holes on the tank

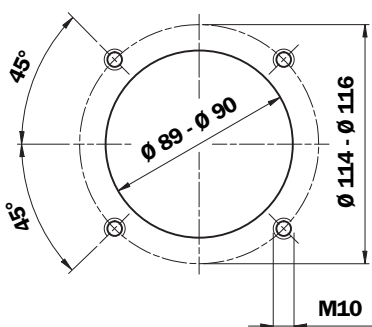

T indicator port
G 1/4" - 1/4" NPT
ON REQUEST

Filter Length	H1 mm	H2 mm	H3 mm
1	188	129	255
2	188	173	255
3	238	223	305
4	338	323	405
5	438	423	505

Thread connections A

Type	A	T
G1	G 3/4"	G 1/8"
G2	G 1"	G 1/8"
G3	G 1 1/4"	G 1/8"
G4	3/4" NPT	1/8" NPT
G5	1" NPT	1/8" NPT
G6	1 1/4" NPT	1/8" NPT
G7	SAE 12 - 1 1/16" - 12 UN	1/8" NPT
G8	SAE 16 - 1 5/16" - 12 UN	1/8" NPT
G9	SAE 20 - 1 5/8" - 12 UN	1/8" NPT

MPH 120

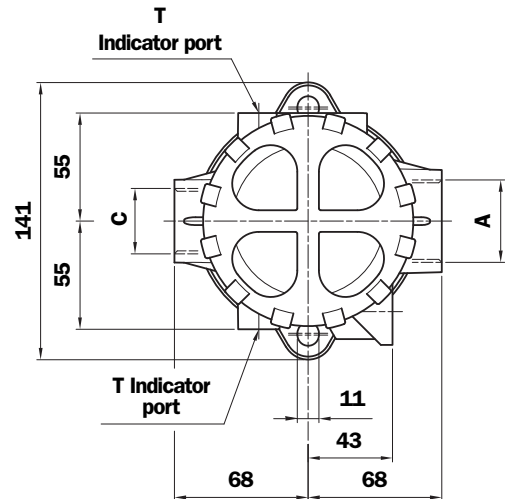
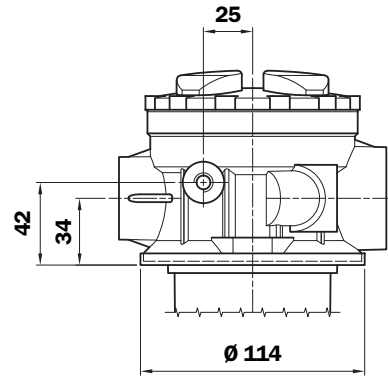
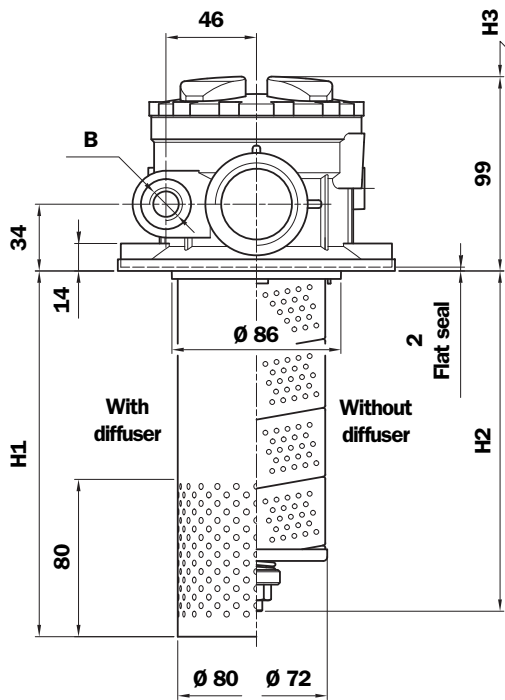

Holes on the tank

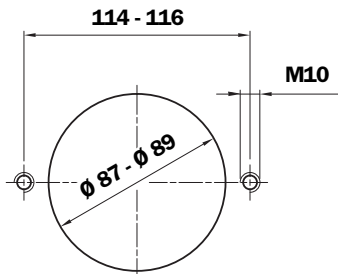

Thread connections A and C

Type	A	C	T
G1	G 3/4"	G 3/4"	G 1/8"
G2	G 1"	G 1"	G 1/8"
G3	G 1 1/4"	G 3/4"	G 1/8"
G4	3/4" NPT	3/4" NPT	1/8" NPT
G5	1" NPT	1" NPT	1/8" NPT
G6	1 1/4" NPT	3/4" NPT	1/8" NPT
G7	SAE 12 - 1 1/16" - 12 UN	SAE 12 - 1 1/16" - 12 UN	1/8" NPT
G8	SAE 16 - 1 5/16" - 12 UN	SAE 16 - 1 5/16" - 12 UN	1/8" NPT
G9	SAE 20 - 1 5/8" - 12 UN	SAE 12 - 1 1/16" - 12 UN	1/8" NPT

Filter Length	H1 mm	H2 mm	H3 mm
1	188	129	255
2	188	173	255
3	238	223	305
4	338	323	405
5	438	423	505

T indicator port
G 1/4" - 1/4" NPT
ON REQUEST

Thread connections A	Thread connections B		
	0	1	2
G1 - G2 - G3	not machined	G 3/8"	G 1/2"
G4 - G5 - G6	not machined	3/8" NPT	1/2" NPT
G7 - G8 - G9	not machined	SAE 6 - 9/16" - 18 UNF	SAE 8 - 3/4" - 16 UNF

MPH 250

1 connection port

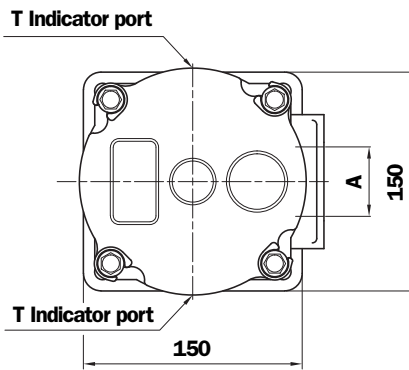
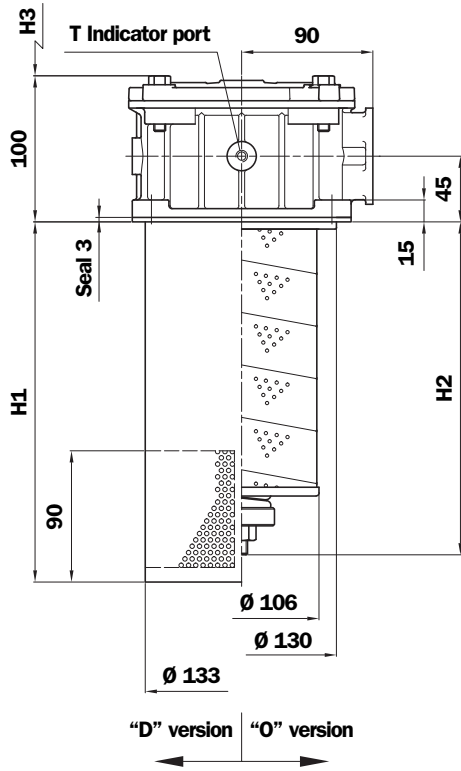

Holes on the tank

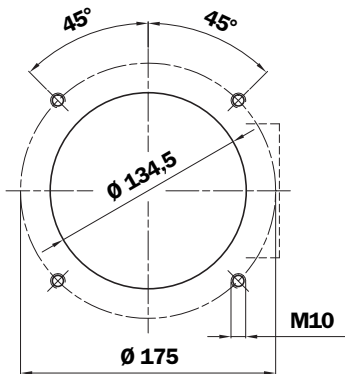

MPH 250

2 connection port

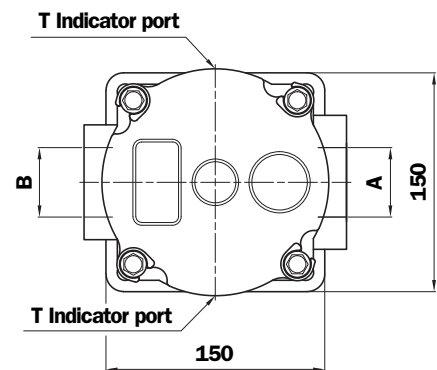
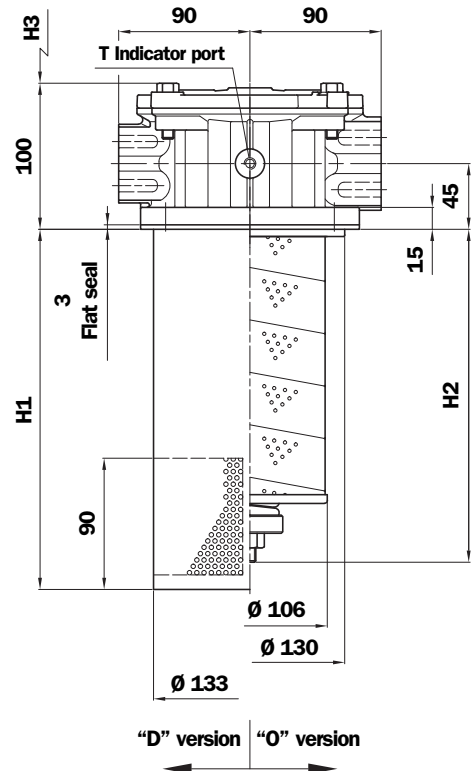

Holes on the tank

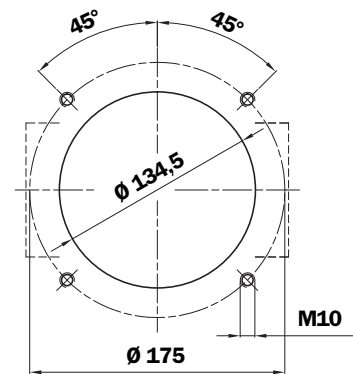

Thread connections

Type	A	B	T
G1	G 1 1/2"	-	G 1/8"
G2	G 1 1/2"	G 1 1/4"	G 1/8"
G4	1 1/2" NPT	-	1/8" NPT
G5	1 1/2" NPT	1 1/4" NPT	1/8" NPT
G7	SAE 24 - 1 7/8" - 12 UN	-	1/8" NPT
G8	SAE 24 - 1 7/8" - 12 UN	SAE 20 - 1 5/8" - 12 UN	1/8" NPT

Filter Length	H1 mm	H2 mm	H3 mm
1	247	182	255
2	247	231	305
3	317	302	375
4	507	502	580

Flange connections*

Type	A	B	T
F1	1 1/2" SAE 3000 psi/M	-	G 1/8"
F2	1 1/2" SAE 3000 psi/M	1 1/4" SAE 3000 psi/M	G 1/8"
F3	1 1/2" SAE 3000 psi/UNC	-	1/8" NPT
F4	1 1/2" SAE 3000 psi/UNC	1 1/4" SAE 3000 psi/UNC	1/8" NPT

*Connections table "DN - SAE flange" see page 5

MPH 630

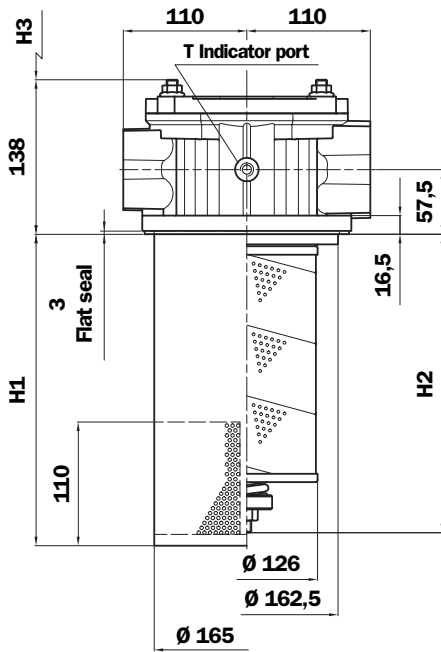

“D” version “O” version

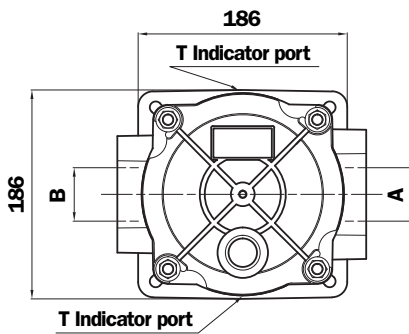

Holes on the tank

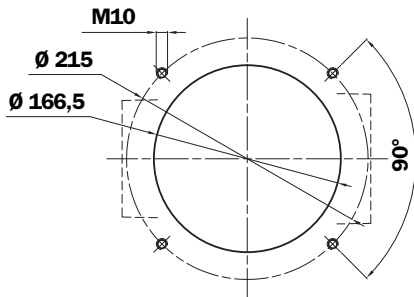

MPH 660

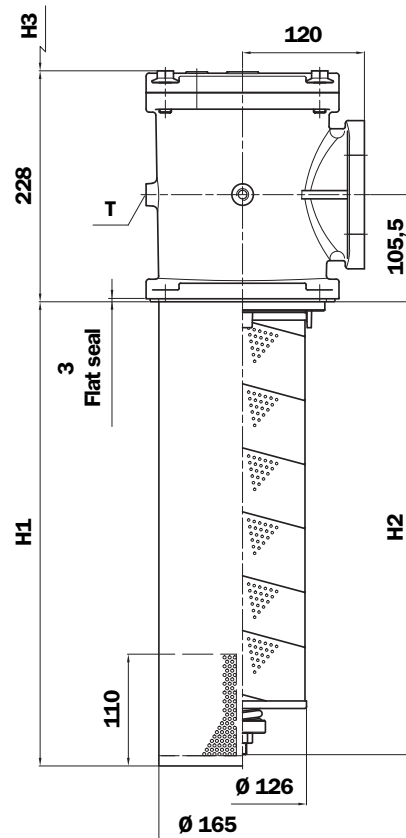

“D” version “O” version

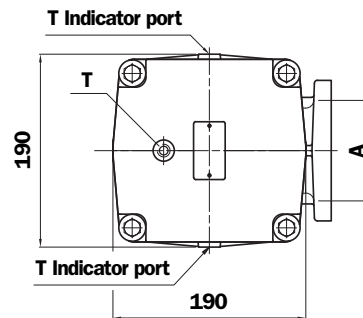

Holes on the tank

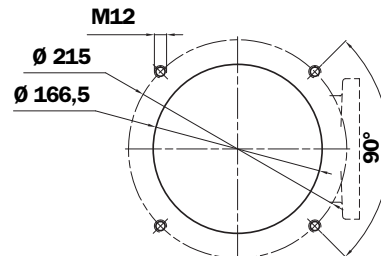

MPH 660

Filter Length	H1 mm	H2 mm	H3 mm
4	548	538	610
5	848	838	910

MPH 660

Flange connections*

Type	A	T
F1	3" SAE 3000 psi/M	G 1/8"
F2	4" SAE 3000 psi/M	G 1/8"

*Connections table "DN - SAE flange" see page 5

MPH 630

Filter Length	H1 mm	H2 mm	H3 mm
1	278	260	330
2	358	340	410
3	458	440	510
4	548	528	600
5	848	829	900

MPH 630

Flange connections*

Type	A	B	T
F1	2 1/2" SAE 3000 psi/M	not machined	G 1/8"
F2	2 1/2" SAE 3000 psi/M	2" SAE 3000 psi/M	G 1/8"
F3	2 1/2" SAE 3000 psi/UNC	not machined	1/8" NPT
F4	2 1/2" SAE 3000 psi/UNC	2" SAE 3000 psi/UNC	1/8" NPT

*Connections table "DN - SAE flange" see page 5

MPH 850

Connection type F1 - F3 (DN - SAE)

Connection type F5 - F6 - F7 - F8 (SAE - SAE)

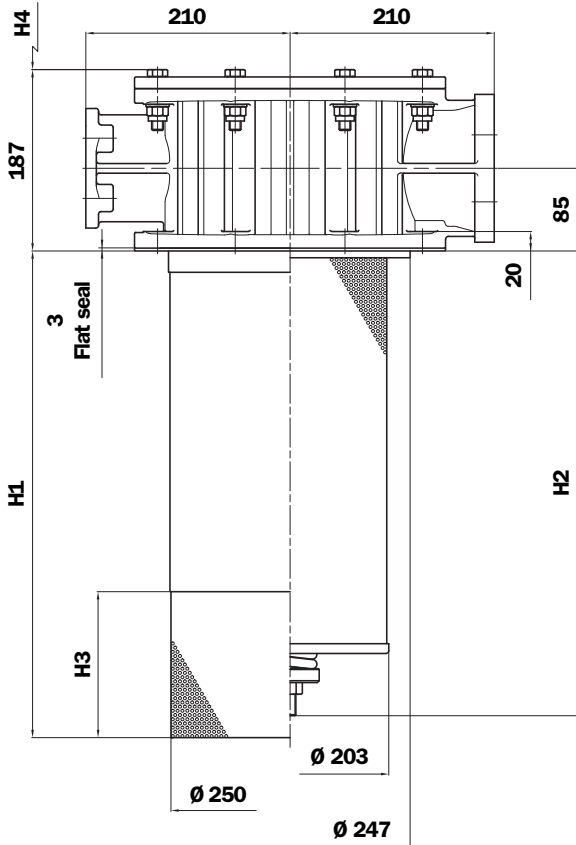

“D” version “O” version

Holes on the tank

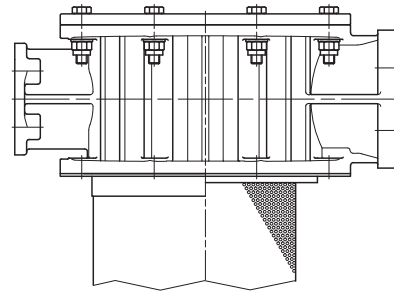
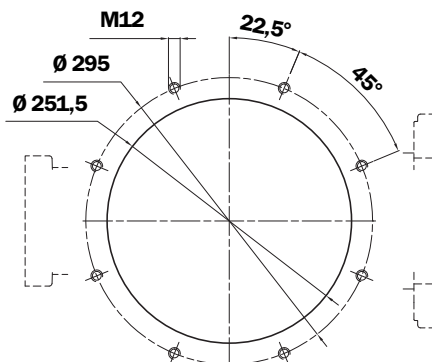

Indicative view for
connection DN - SAE

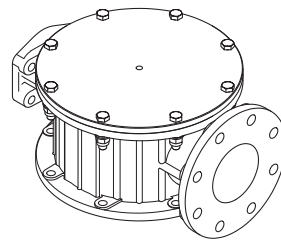

Indicative view for
connection SAE - SAE

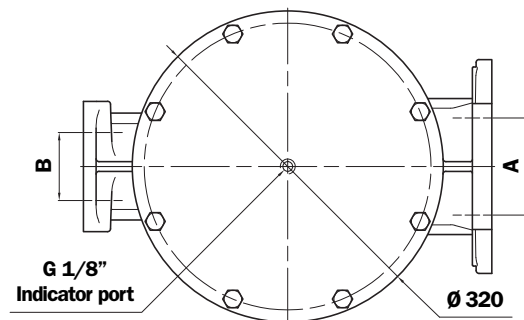

SAE - SAE Flange connections*

Type	A	B
F5	not machined	3" SAE 3000 psi/M
F6	not machined	3" SAE 3000 psi/UNC
F7	4" SAE 3000 psi/M	3" SAE 3000 psi/M
F8	4" SAE 3000 psi/UNC	3" SAE 3000 psi/UNC

*Connections table “DN - SAE flange” see page 5

DN - SAE Flange connections*

Type	A	B
F1	DN 100 PN 10/16 UNI 2223	3" SAE 3000 psi/M
F3	DN 100 PN 10/16 UNI 2223	3" SAE 3000 psi/UNC

Filter Length	H1 mm	H2 mm	H3 mm	H4 mm
1	419	383	150	515
2	634	598	150	730
3	914	878	250	1010
4	1179	1143	250	1275

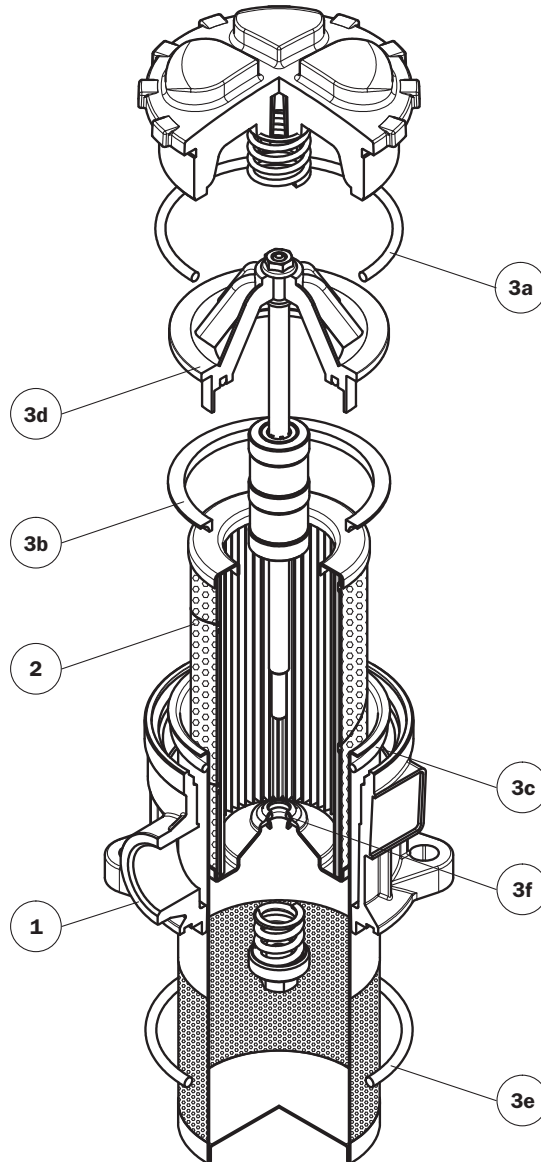

Item	Description	Q.ty	FILTER Series MPH 104	
1	Filter assembly	1	See order table	
2	Filter element	1	See order table	
3	Seal Kit	1	NBR 02050390	FPM 02050409
3a	Cover seal	1	O-R Metric Ø 90 x 4	
3b	External seal for insert assembly with diffuser	1	01026554	01026560
	External seal for insert assembly without diffuser	1	O-R 4275 Ø 69,44 x 3,53	
3c	Diffuser seal	1	O-R 4312 Ø 78,97 x 3,53	
3d	Insert assembly	1	02019052	02019053
3e	Head seal without air breather	1	O-R Metric Ø 90 x 4	
3f	Filter element seal	1	O-R Metric Ø 7,5 x 3	

Spare parts

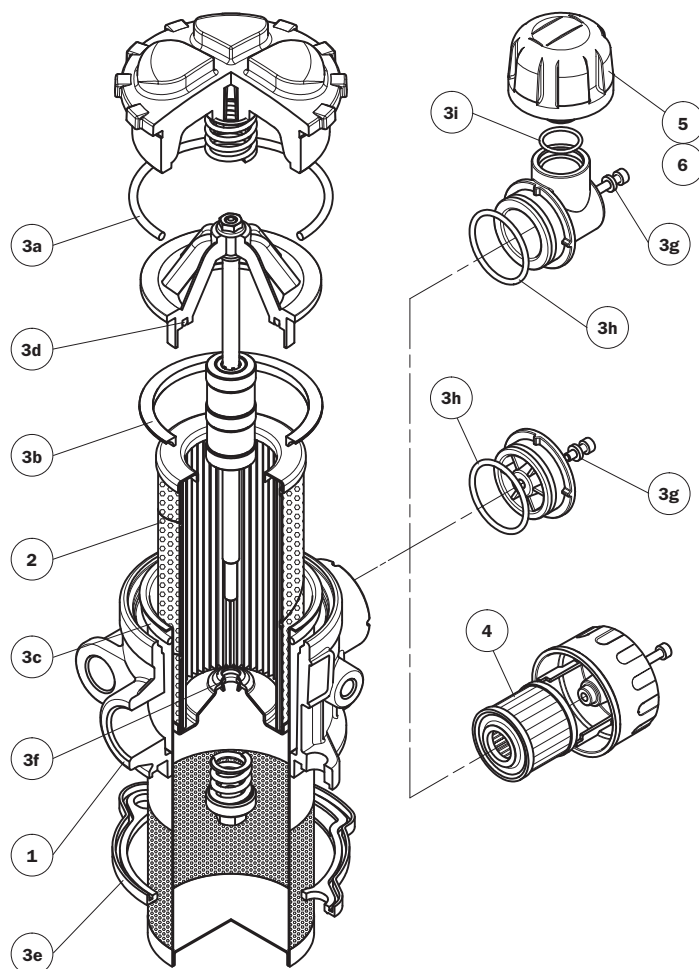

Item	Description	Q.ty	FILTER Series MPH 110		FILTER Series MPH 114	
			NBR 02050565	FPM 02050566	NBR 02050582	FPM 02050583
1	Filter assembly	1	See order table		See order table	
2	Filter element	1	See order table		See order table	
3	Seal Kit	1	NBR 02050565	FPM 02050566	NBR 02050582	FPM 02050583
3a	Cover seal	1	O-R Metric Ø 90 x 4		O-R Metric Ø 90 x 4	
3b	External seal for insert assembly with diffuser	1	01026554	01026560	01026554	01026560
	External seal for insert assembly without diffuser	1	O-R 4275 Ø 69,44 x 3,53		O-R 4275 Ø 69,44 x 3,53	
3c	Diffuser seal	1	O-R 4312 Ø 78,97 x 3,53		O-R 4312 Ø 78,97 x 3,53	
3d	Insert assembly internal seal	1	01026295	01026296	01026295	01026296
3e	Head seal	1	01026351	01026352	01026371	01026372
3f	Filter element seal	1	O-R Metric Ø 7,5 x 3		O-R Metric Ø 7,5 x 3	
3g	Air breather screw seal	1	01026346	01026347	01026346	01026347
3h	Plug - Anti-splash seal	1	O-R 3131 Ø 32,99 x 2,62		O-R 3131 Ø 32,99 x 2,62	
3i	SAP50 seal	1	O-R 2068 Ø 17,17 x 1,78		O-R 2068 Ø 17,17 x 1,78	
4	Air breather filter element "C" version	1	10 micron A3L03		10 micron A3L03	
5	Air breather filter element "D" version	1	10 micron SAP50G3L03A0P01		10 micron SAP50G3L03A0P01	
6	Air breather filter element "P" version	1	10 micron SAP50G3L03A1P01		10 micron SAP50G3L03A1P01	

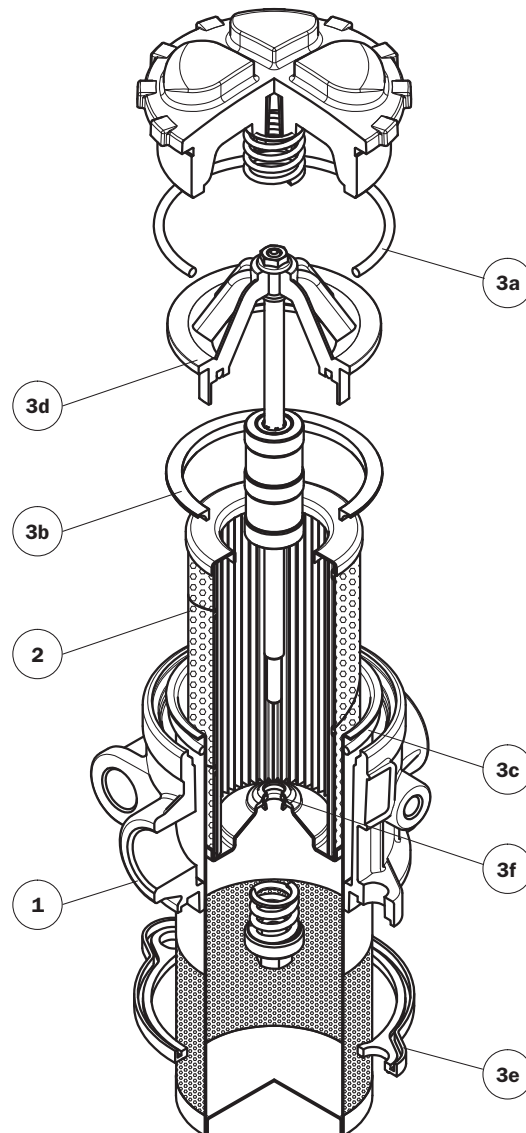

Item	Description	Q.ty	FILTER Series MPH 120	
1	Filter assembly	1	See order table	
2	Filter element	1	See order table	
3	Seal Kit	1	NBR 02050567	FPM 02050568
3a	Cover seal	1	O-R Metric Ø 90 x 4	
3b	External seal for insert assembly with diffuser	1	01026554	01026560
	External seal for insert assembly without diffuser	1	O-R 4275 Ø 69,44 x 3,53	
3c	Diffuser seal	1	O-R 4312 Ø 78,97 x 3,53	
3d	Insert assembly internal seal	1	01026295	01026296
3e	Head seal	1	01026361	01026362
3f	Filter element seal	1	O-R Metric Ø 7,5 x 3	

Spare parts

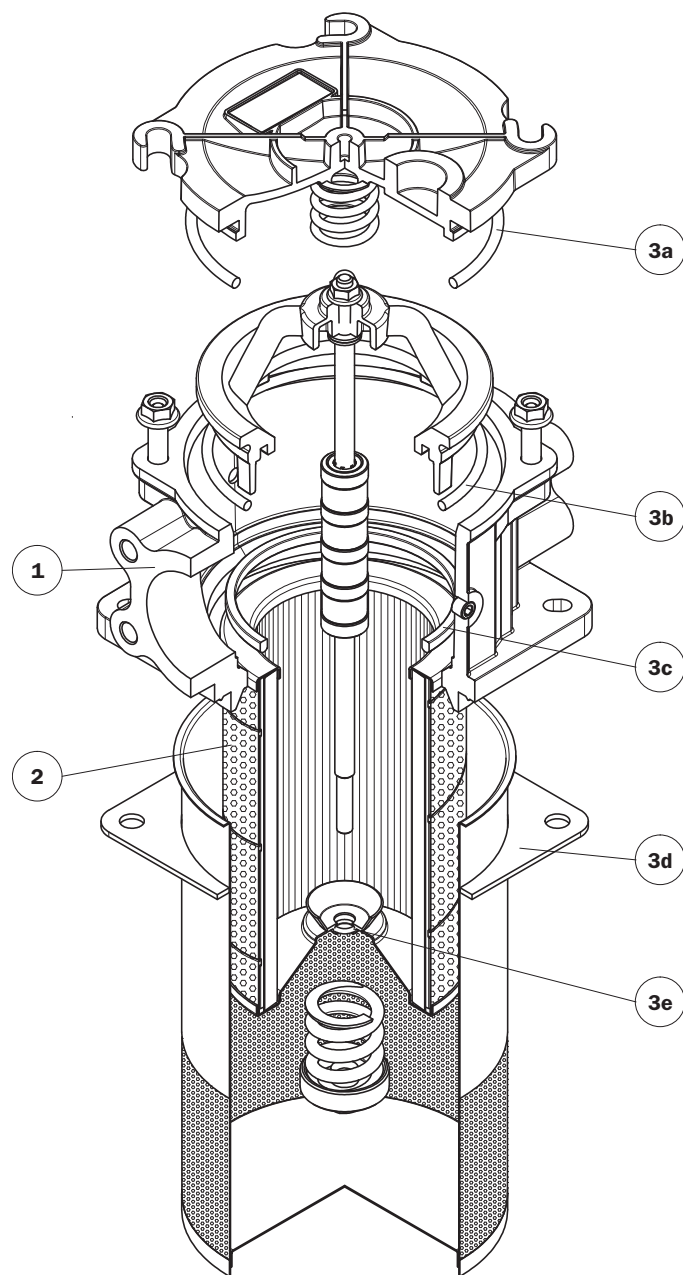

Item	Description	Q.ty	FILTER Series			
			MPH 250		MPH 630	
1	Filter assembly	1	See order table			
2	Filter element	1	See order table			
3	Seal Kit	1	NBR 02050151	FPM 02050152	NBR 02050153	FPM 02050154
3a	Cover seal	1	O-R Metric Ø 119 x 5,7		O-R Metric Ø 149,3 x 5,7	
3b	Insert assembly external seal	1	O-R 4437 Ø 110,70 x 3,53		O-R 210 Ø 133,40 x 5,34	
3c	Insert assembly internal seal	1	01026217	01026220	01026228	01026229
3d	Head seal	1	01026549	01026561	01026545	01026562
3e	Filter element seal	1	O-R 112 Ø 9,92 x 2,62		O-R 112 Ø 9,92 x 2,62	

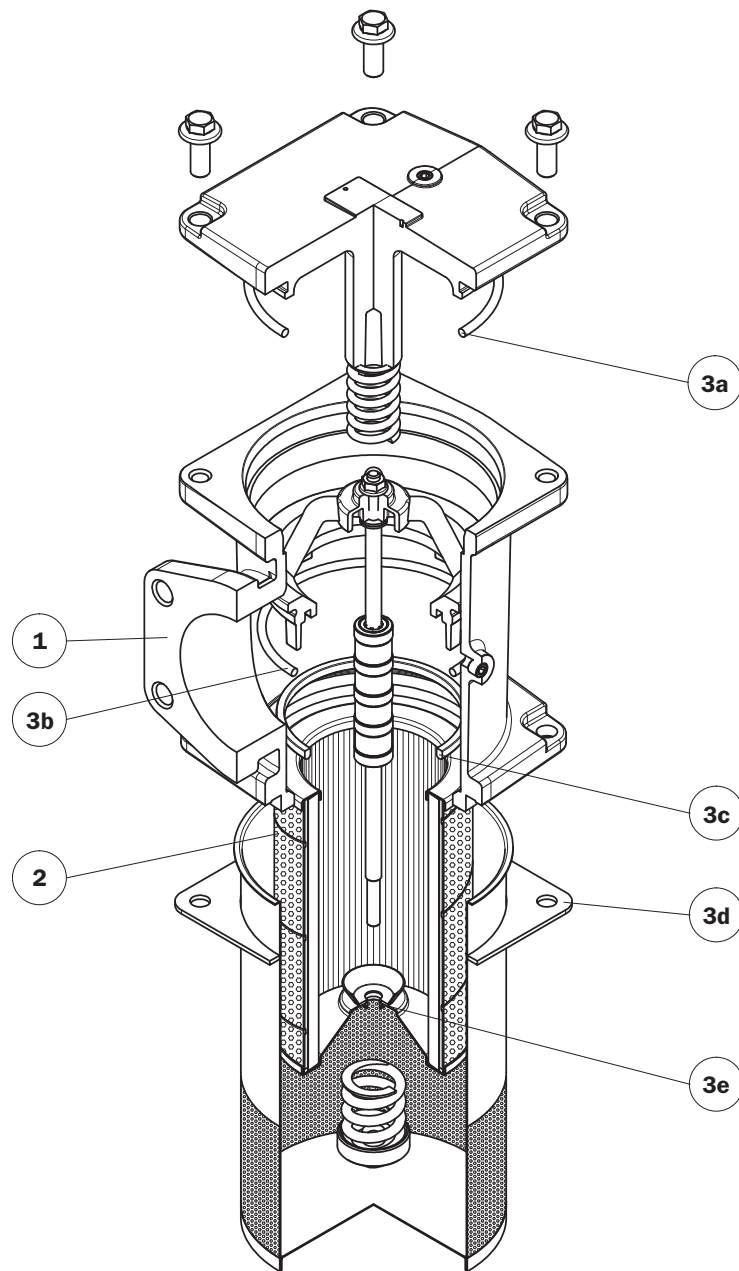

Item	Description	Q.ty	FILTER Series MPH 660	
1	Filter assembly	1	See order table	
2	Filter element	1	See order table	
3	Seal Kit	1	NBR 02050153	FPM 02050154
3a	Cover seal	1	O-R Metric Ø 149,30 x 5,7	
3b	Insert assembly external seal	1	O-R 210 Ø 133,40 x 5,34	
3c	Insert assembly internal seal	1	01026228	01026229
3d	Head seal	1	01026545	01026562
3e	Filter element seal	1	O-R 112 Ø 9,92 x 2,62	

Spare parts

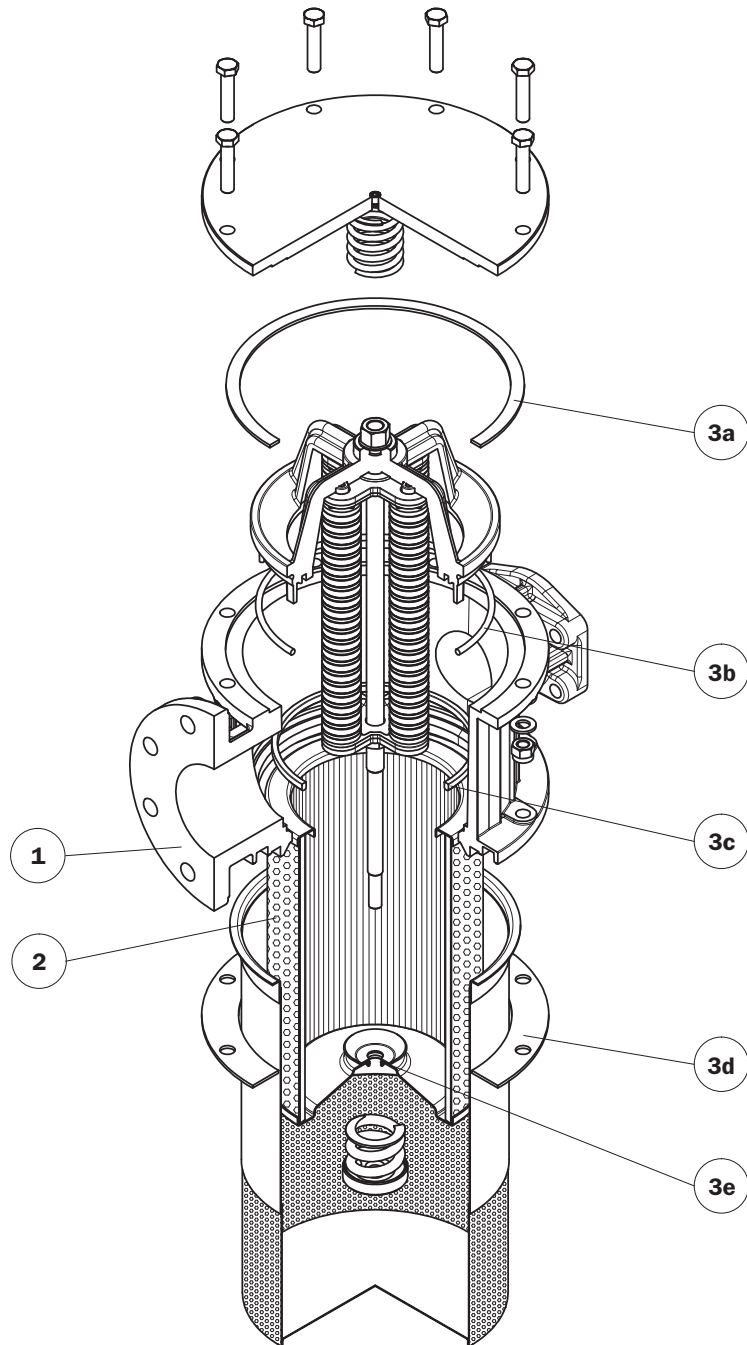

Item	Description	Q.ty	FILTER Series MPH 850	
1	Filter assembly	1	See order table	
2	Filter element	1	See order table	
3	Seal Kit	1	NBR 02050155	FPM 02050156
3a	Cover seal	1	01026185	01026564
3b	Insert assembly external seal	1	O-R Metric Ø 209,30 x 5,70	
3c	Insert assembly internal seal	1	01026248	01026249
3d	Head seal	1	01026325	01026563
3e	Filter element seal	1	O-R 117 Ø 13,10 x 2,62	

Ordering information MPH 104-114

Filter assembly	1	2	3	4	5	6	7	8	9
MPH	<input type="checkbox"/>	<input type="checkbox"/>	<input type="checkbox"/>	<input type="checkbox"/>	<input type="checkbox"/>	<input type="checkbox"/>	<input type="checkbox"/>	<input type="checkbox"/>	<input type="checkbox"/>

Example 1: MPH **104 1 C D S A G1 A25 P01**
 Example 2: MPH **114 3 E D C A G2 M60 P01**

Filter element	1	2	8	6	9
MR	<input type="checkbox"/>	<input type="checkbox"/>	<input type="checkbox"/>	<input type="checkbox"/>	<input type="checkbox"/>

Example 1: MR **100 1 A25 A P01**
 Example 2: MR **100 3 M60 A P01**

1 - Style

Filter	Filter element
<input type="checkbox"/> 104	<input type="checkbox"/> 100
<input type="checkbox"/> 114	<input type="checkbox"/> 100

2 - Filter length

<input type="checkbox"/> 104	<input type="checkbox"/> 1	<input type="checkbox"/> 2	<input type="checkbox"/> 3	<input type="checkbox"/> 4	<input type="checkbox"/> 5
<input type="checkbox"/> 114	<input type="checkbox"/> 1	<input type="checkbox"/> 2	<input type="checkbox"/> 3	<input type="checkbox"/> 4	<input type="checkbox"/> 5

3 - By-pass valve

<input type="checkbox"/> S	Without bypass
<input type="checkbox"/> C	1,75 bar
<input type="checkbox"/> E	2,5 bar

4 - Execution

<input type="checkbox"/> O	Without diffuser and with magnetic column
* <input type="checkbox"/> D	With diffuser and with magnetic column
<input type="checkbox"/> E	Without diffuser and without magnetic column
* <input type="checkbox"/> F	With diffuser and without magnetic column

5 - Air breather

<input type="checkbox"/> S	Without air breather
<input type="checkbox"/> C	(1) With air breather 10 μ
<input type="checkbox"/> D	(1) Anti-splash and SAP50 10 μ air breather
<input type="checkbox"/> P	(1) Anti-splash, SAP50 10 μ air breather and pressurization 0,5 bar

(1) Excluded MPH 104

6 - Filter seals & Treatment

<input type="checkbox"/> A	NBR
<input type="checkbox"/> V	FPM
<input type="checkbox"/> W	NBR, Head anodized - filter element compatible with fluid HFA, HFB, HFC (only for filter element type Axx and Mxx)
<input type="checkbox"/> Z	FPM, Head anodized - filter element compatible with fluid HFA, HFB, HFC (only for filter element type Axx and Mxx)

* Use of diffuser recommended

7 - Connections

MPH 104 - 114

Type	A
G1	G 3/4"
G2	G 1"
G3	G 1 1/4"
G4	3/4" NPT
G5	1" NPT
G6	1 1/4" NPT
G7	SAE 12 - 1 1/6" - 12 UN
G8	SAE 16 - 1 5/16" - 12 UN
G9	SAE 20 - 1 5/8" - 12 UN

8 - Filter element

<input type="checkbox"/> A03	Inorganic microfibre 6 μ	Absolute filtration βx (c) ≥ 1000
<input type="checkbox"/> A10	Inorganic microfibre 10 μ	
<input type="checkbox"/> A25	Inorganic microfibre 25 μ	
<input type="checkbox"/> M25	Wire mesh	Nominal Filtration
<input type="checkbox"/> M60	Wire mesh	
<input type="checkbox"/> M90	Wire mesh	
<input type="checkbox"/> P10	Resin impregnated paper	Nominal Filtration
<input type="checkbox"/> P25	Resin impregnated paper	

9 - Option

<input type="checkbox"/> P01	MP Filtri standard
------------------------------	--------------------

MP Filtri - The filter functions as described in this bulletin are valid exclusively for original MP Filtri filter elements and replacement parts. All rights reserved

The data in this publication are purely guideline. MP Filtri reserves the right to make changes to the models described herein at any time it deems fit in relation to technical or commercial requirements. The colours of the products shown on the cover are purely guideline. Copyright. All rights reserved.

Ordering information MPH 110-120

Filter assembly

MPH

	1	2	3	4	5	6	7	8	9	10
	<input type="checkbox"/>	<input type="checkbox"/>	<input type="checkbox"/>	<input type="checkbox"/>	<input type="checkbox"/>	<input type="checkbox"/>	<input type="checkbox"/>	<input type="checkbox"/>	<input type="checkbox"/>	<input type="checkbox"/>
Example 1: MPH	110	2	E	D	C	A	G2	1	A10	P01
Example 2: MPH	120	5	C	O		A	G3	2	A25	P01

Filter element

MR

	1	2	9	6	10
	<input type="checkbox"/>	<input type="checkbox"/>	<input type="checkbox"/>	<input type="checkbox"/>	<input type="checkbox"/>
Example 1: MR	100	2	A10	A	P01
Example 2: MR	100	5	A25	A	P01

1 - Style

Filter

110
120

Filter element

100
100

2 - Filter length

110
120

1	2	3	4	5
1	2	3	4	5

3 - By-pass valve

S	Without bypass
C	1,75 bar
E	2,5 bar

4 - Execution

O	Without diffuser and with magnetic column
* D	With diffuser and with magnetic column
E	Without diffuser and without magnetic column
* F	With diffuser and without magnetic column

5 - Air breather (omit for MPH 120)

S	Without air breather
C	With air breather 10 μ
D	Anti-splash and SAP50 10 μ air breather
P	Anti-splash and SAP50 10 μ air breather pressurization 0,5 bar

6 - Filter seals & Treatment

A	NBR
V	FPM
W	NBR, Head anodized - filter element compatible with fluid HFA, HFB, HFC (only for filter element type Axx and Mxx)
Z	FPM, Head anodized - filter element compatible with fluid HFA, HFB, HFC (only for filter element type Axx and Mxx)

7 - Connections A - C

MPH 110 Connections A MPH 120 Connections A and C

Type	A	C
G1	G 3/4"	G 3/4"
G2	G 1"	G 1"
G3	G 1 1/4"	G 3/4"
G4	3/4" NPT	3/4" NPT
G5	1" NPT	1" NPT
G6	1 1/4" NPT	3/4" NPT
G7	SAE 12 - 1 1/16" - 12 UN	SAE 12 - 1 1/16" - 12 UN
G8	SAE 16 - 1 5/16" - 12 UN	SAE 16 - 1 5/16" - 12 UN
G9	SAE 20 - 1 5/8" - 12 UN	SAE 12 - 1 1/16" - 12 UN

8 - Connections B

Type	Connections A		
	G1 - G2 - G3	G4 - G5 - G6	G7 - G8 - G9
0	not machined	not machined	not machined
1	G 3/8"	3/8" NPT	SAE 6 - 9/16" - 18 UNF
2	G 1/2"	1/2" NPT	SAE 8 - 3/4" - 16 UNF

9 - Filter element

A03	Inorganic microfibre 3 μ	Absolute filtration $\beta_x(c) \geq 1000$
A06	Inorganic microfibre 6 μ	
A10	Inorganic microfibre 10 μ	
A16	Inorganic microfibre 16 μ	
A25	Inorganic microfibre 25 μ	Nominal Filtration
M25	Wire mesh	
M60	Wire mesh	
M90	Wire mesh	Nominal Filtration
P10	Resin impregnated paper	
P25	Resin impregnated paper	

10 - Option

P01	MP Filtri standard
------------	--------------------

* Use of diffuser recommended

MP Filtri - The filter functions as described in this bulletin are valid exclusively for original MP Filtri filter elements and replacement parts. All rights reserved

The data in this publication are purely guideline. MP Filtri reserves the right to make changes to the models described herein at any time it deems fit in relation to technical or commercial requirements. The colours of the products shown on the cover are purely guideline. Copyright. All rights reserved.

Ordering information MPH 250-630-660-850

Filter assembly

MPH

Example: MPH

1	2	3	4	5	6	7	8	9
<input type="checkbox"/>	<input type="checkbox"/>	<input type="checkbox"/>	<input type="checkbox"/>	<input type="checkbox"/>	<input type="checkbox"/>	<input type="checkbox"/>	<input type="checkbox"/>	<input type="checkbox"/>
250	1	C	D	S	A	G1	A25	P01

Filter element

MR

Example: MR

1	2	8	6	9
<input type="checkbox"/>	<input type="checkbox"/>	<input type="checkbox"/>	<input type="checkbox"/>	<input type="checkbox"/>
250	1	A10	A	P01

1 - Style

Filter

250
630
660
850

Filter element

250
630
630
850

2 - Filter length

250
630
660
850

1	2	3	4	
1	2	3	4	5
			4	5
1	2	3	4	

3 - By-pass valve

S	Without bypass
C	1,75 bar
E	2,5 bar (not available for MPH 850)

4 - Execution

O	Without diffuser and with magnetic column
* D	With diffuser and with magnetic column
E	Without diffuser and without magnetic column
* F	With diffuser and without magnetic column

5 - Air breather

S	Without air breather
----------	----------------------

6 - Filter seals & Treatment

A	NBR
V	FPM
W	NBR, Head and Insert assembly anodized. Filter element compatible with fluid HFA, HFB, HFC (only for filter element type Axx and Mxx)
Z	FPM, Head and Insert assembly anodized. Filter element compatible with fluid HFA, HFB, HFC (only for filter element type Axx and Mxx)

7 - Connections

MPH 250

Type	A	B
G1	G 1 1/2"	-
G2	G 1 1/2"	G 1 1/4"
G4	1 1/2" NPT	-
G5	1 1/2" NPT	1 1/4" NPT
G7	SAE 24 - 1 7/8" 12 UN	-
G8	SAE 24 - 1 7/8" 12 UN	SAE 20 - 1 5/8" - 12 UN
F1	1 1/2" SAE 3000 psi/M	-
F2	1 1/2" SAE 3000 psi/M	1 1/4" SAE 3000 psi/M
F3	1 1/2" SAE 3000 psi/UNC	-
F4	1 1/2" SAE 3000 psi/UNC	1 1/4" SAE 3000 psi/UNC

MPH 630

Type	A	B
F1	2 1/2" SAE 3000 psi/M	not machined
F2	2 1/2" SAE 3000 psi/M	2" SAE 3000 psi/M
F3	2 1/2" SAE 3000 psi/UNC	not machined
F4	2 1/2" SAE 3000 psi/UNC	2" SAE 3000 psi/UNC

MPH 660

Type	A
F1	3" SAE 3000 psi/M
F2	4" SAE 3000 psi/M

MPH 850 DN-SAE

Type	A	B
F1	DN 100 PN 10/16 UNI 2223	3" SAE 3000 psi/M
F3	DN 100 PN 10/16 UNI 2223	3" SAE 3000 psi/UNC

MPH 850 SAE-SAE

Type	A	B
F5	not machined	3" SAE 3000 psi/M
F6	not machined	3" SAE 3000 psi/UNC
F7	4" SAE 3000 psi/M	3" SAE 3000 psi/M
F8	4" SAE 3000 psi/UNC	3" SAE 3000 psi/UNC

8 - Filter element

A03	Inorganic microfibre 6 μ	Absolute filtration $\beta_x(c) \geq 1000$
A10	Inorganic microfibre 10 μ	
A25	Inorganic microfibre 25 μ	
M25	Wire mesh	Nominal Filtration
M60	Wire mesh	
M90	Wire mesh	
P10	Resin impregnated paper	Nominal Filtration
P25	Resin impregnated paper	

9 - Option

P01	MP Filtri standard
------------	--------------------

* Use of diffuser recommended

MP Filtri - The filter functions as described in this bulletin are valid exclusively for original MP Filtri filter elements and replacement parts. All rights reserved

The data in this publication are purely guideline. MP Filtri reserves the right to make changes to the models described herein at any time it deems fit in relation to technical or commercial requirements. The colours of the products shown on the cover are purely guideline. Copyright. All rights reserved.

MPI



Maximum pressure 10 bar
Flow rates to 3000 l/min

Filter housing (Materials)

- Insert assembly: Nylon (only for: MPI 100)
Aluminium (all the other)
- Diffuser: Zinc Plated steel
- Valve: Steel

Pressure

- Working pressure: 10 bar (1 MPa)

Temperature

- From -25 °C to +110 °C

Bypass valve

- Opening pressure 1,75 bar ±10%
- Opening pressure 2,5 bar ±10% (excluded for MPI 850)

Δp Elements type

- Series MR elements: 10 bar
- Oil flow from inside to outside.

Seals

- Standard NBR series A
- Optional FPM series V

MPI FILTERS ARE PROVIDED FOR VERTICAL MOUNTING

Weights (kg)

Length	1	2	3	4
• MPI 100	0,90	1,00	1,20	1,50
• MPI 250	2,20	2,50	2,90	4,30
• MPI 630	3,40	3,90	4,30	5,40
• MPI 850	15,2	18,2	21,2	25,2

Recommended maximum flow rate

- Pressure drop of filter assembly equal to Δp 0,5 bar.
- Oil kinematic viscosity 30 mm²/s (cSt).
- Density 0,86 kg/dm³.

Volumes (dm³)

Length	1	2	3	4
• MPI 100	0,90	0,90	1,20	1,60
• MPI 250	3,50	3,50	4,50	7,00
• MPI 630	5,80	7,40	9,50	11,4
• MPI 850	8,80	12,2	16,7	20,8

Compatibility (to ISO 2943)

- Housings/Diffuser compatible with:
Mineral oils, synthetic fluids.
Aqueous emulsions, water and glycol
(series W required).
- The filter elements are compatible with:
Mineral oils, synthetic fluids.
Aqueous emulsions, water and glycol
(series W required).
- NBR seals series A, compatible with:
Mineral oils, synthetic fluids.
Aqueous emulsions, water and glycol.
- FPM seals V series, compatible with:
Synthetic fluids type HS-HFDR-HFDS-HFDU

Filtration

	Length	A03	A06	A10	A16	A25	P10	P25	M25 - M60 - M90
MPI 100	1	26	29	72	80	106	160	185	280
	2	42	45	110	115	160	164	187	300
	3	63	72	130	155	175	215	245	300
	4	89	98	180	198	215	265	300	300
	5	115	125	200	218	240	280	300	300
MPI 250	1	92	100	205	245	300	330	370	700
	2	120	145	310	410	420	462	517	700
	3	185	215	415	402	500	550	616	700
	4	255	295	550	615	750	825	700	700
MPI 630	1	160	198	360	410	510	561	628	1200
	2	235	250	555	600	1025	1128	1200	1200
	3	325	370	730	770	1200	1200	1200	1200
	4	370	400	870	990	1200	1200	1200	1200
	5	610	690	1180	1200	1200	1200	1200	1200
MPI 850	1	770	1030	1240	1550	2230	2600	2650	3000
	2	1170	1520	1680	1740	2440	2684	2900	3000
	3	1480	1910	1990	2010	3000	3000	3000	3000
	4	1660	2080	2300	2360	3000	3000	3000	3000

Flow rate l/min

Dimensions

MPI With diffuser

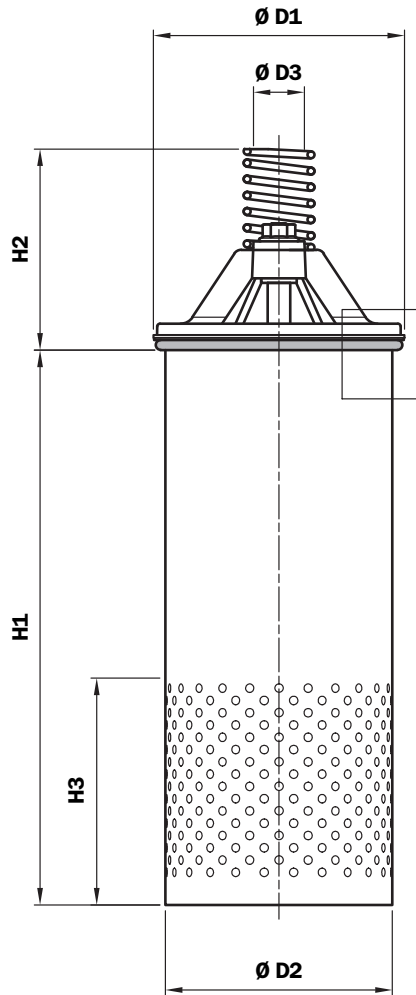

Version MPI 100

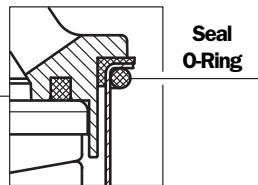

Version MPI 250 - 630 - 850

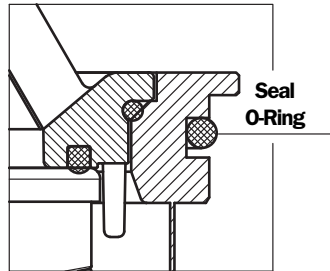

Type	H1 mm	H2 mm	H3 mm	H4 mm	H5 mm
MPI 100-1	198				
MPI 100-2	198				
MPI 100-3	248	62	80	4	12
MPI 100-4	348				
MPI 100-5	448				
MPI 250-1	266				
MPI 250-2	266	81	90	4	15
MPI 250-3	336				
MPI 250-4	524				
MPI 630-1	298				
MPI 630-2	378				
MPI 630-3	478	103	110	5	15
MPI 630-4	568				
MPI 630-5	868				
MPI 850-1	427		150		
MPI 850-2	642	145	150	5	17
MPI 850-3	922		250		
MPI 850-4	1187		250		

Type	Ø D1	Ø D2	Ø D3	Ø D4	Ø D5
MPI 100-1					
MPI 100-2					
MPI 100-3	88,5	80	18	81	90
MPI 100-4					
MPI 100-5					
MPI 250-1					
MPI 250-2	155	132	25	145	-
MPI 250-3					
MPI 250-4					
MPI 630-1					
MPI 630-2					
MPI 630-3	185	165	25	178	-
MPI 630-4					
MPI 630-5					
MPI 850-1					
MPI 850-2	260	250	40	250,5	-
MPI 850-3					
MPI 850-4					

Filter seat
MPI 100

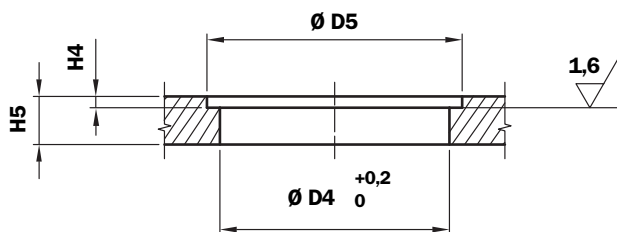

Filter seat
MPI 250 - 630 - 850

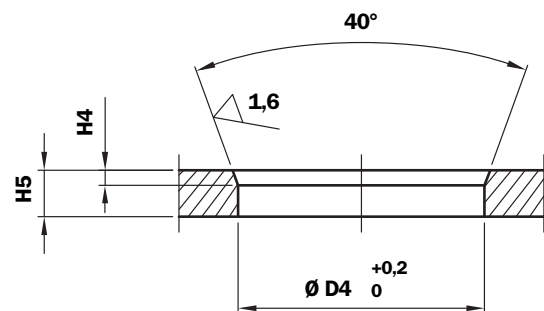

MPI

Without diffuser

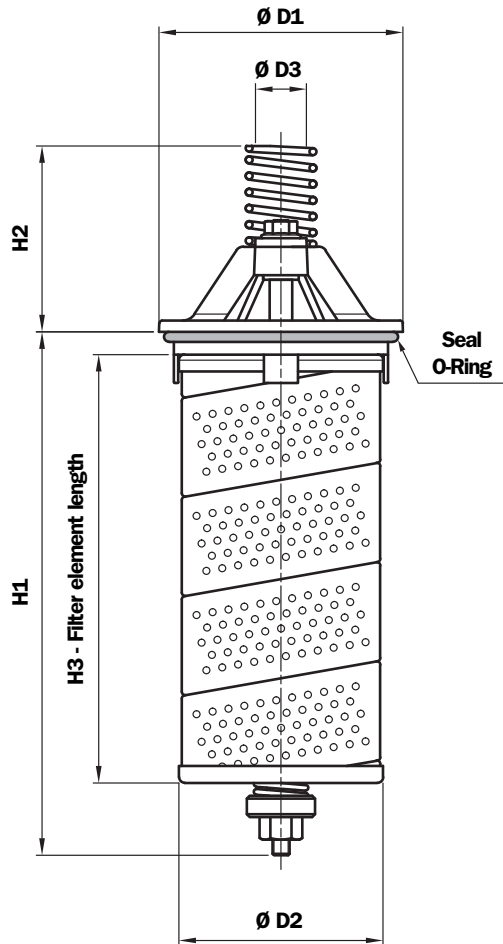

Filter seat

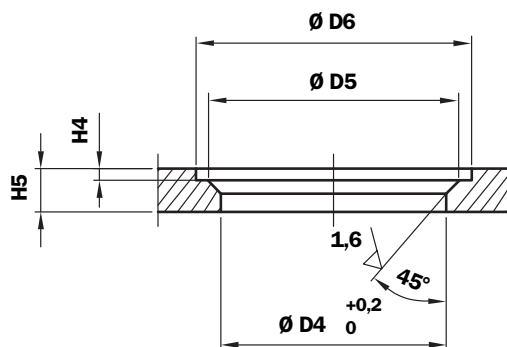

Type	H1 mm	H2 mm	H3 mm	H4 mm	H5 mm
MPI 100-1	141		110		
MPI 100-2	185		150		
MPI 100-3	235	57	200	4	12
MPI 100-4	335		300		
MPI 100-5	435		400		
MPI 250-1	193		140		
MPI 250-2	243	82	190	5	12
MPI 250-3	313		260		
MPI 250-4	516		463		
MPI 630-1	275		210		
MPI 630-2	355		290		
MPI 630-3	455	105	390	7	15
MPI 630-4	540		478		
MPI 630-5	841		779		
MPI 850-1	405		327		
MPI 850-2	620	145	542	8	15
MPI 850-3	900		819		
MPI 850-4	1165		1090		

Type	Ø D1	Ø D2	Ø D3	Ø D4	Ø D5	Ø D6
MPI 100-1						
MPI 100-2						
MPI 100-3	87	72	18	76	86	88
MPI 100-4						
MPI 100-5						
MPI 250-1						
MPI 250-2	125	106	25	117	123,5	126
MPI 250-3						
MPI 250-4						
MPI 630-1						
MPI 630-2						
MPI 630-3	150	126	25	139	149	151
MPI 630-4						
MPI 630-5						
MPI 850-1						
MPI 850-2	230	203	40	217	227	231
MPI 850-3						
MPI 850-4						

Spare parts

With diffuser

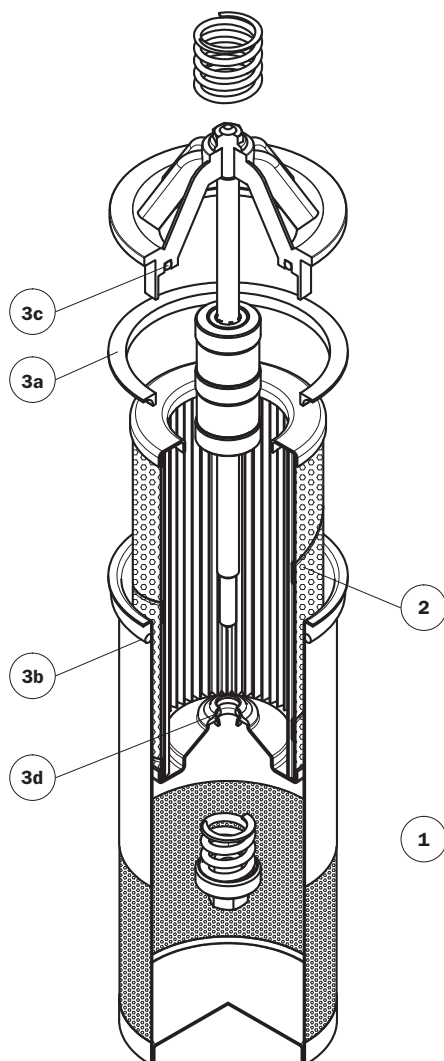

Without diffuser

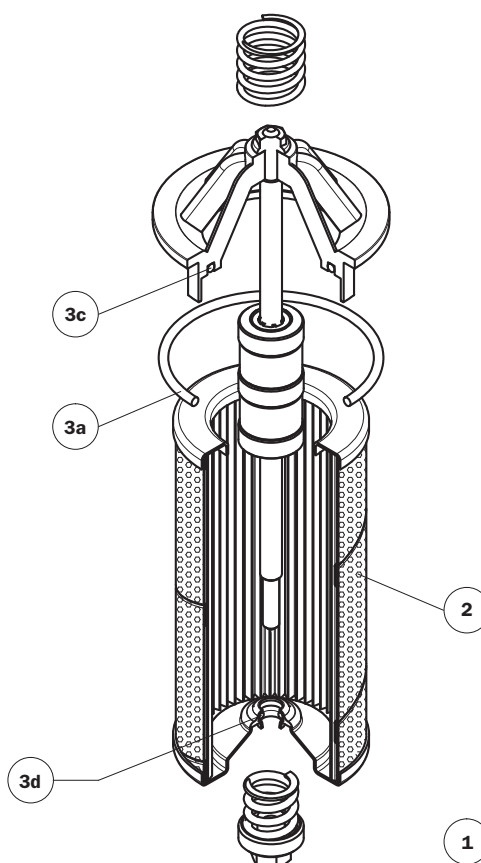

Item	Description	Q.ty	FILTER Series MPI 100	
1	Filter assembly	1	See order table	
2	Filter element	1	See order table	
3	Seal Kit	1	NBR 02050145	FPM 02050146
3a	Insert assembly external seal version with diffuser	1	01026554	01026560
	Insert assembly external seal version without diffuser	1	O-R 4275 Ø 69,44 x 3,53	
3b	Diffuser seal	1	O-R 4312 Ø 78,97 x 3,53	
3c	Insert assembly	1	02019052	02019053
3d	Filter element seal	1	O-R Metric Ø 7,5 x 3	

With diffuser

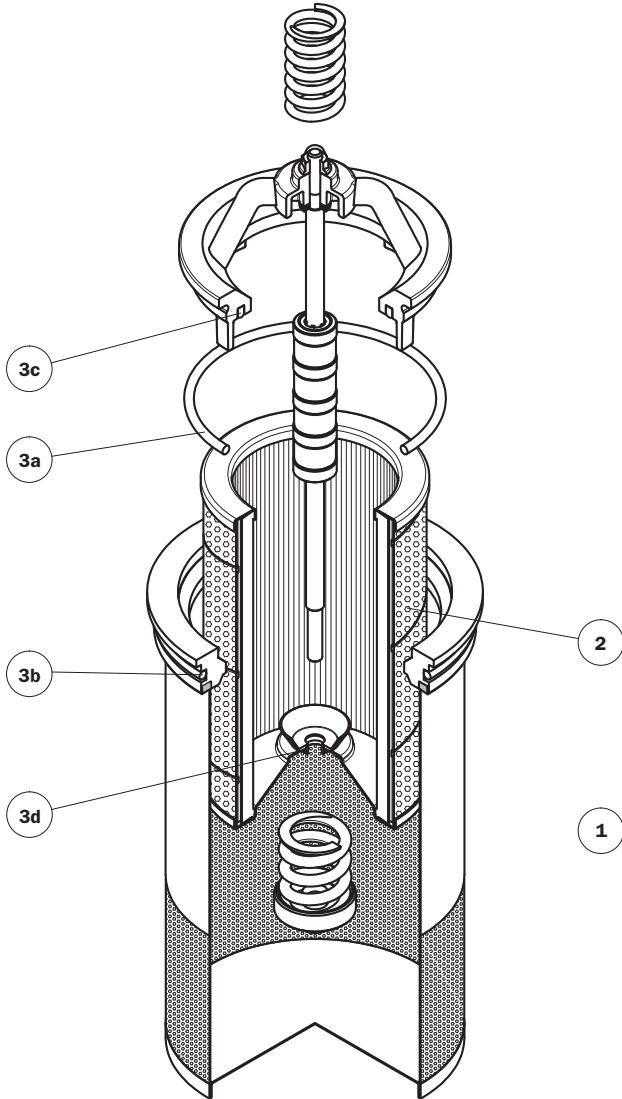

Without diffuser

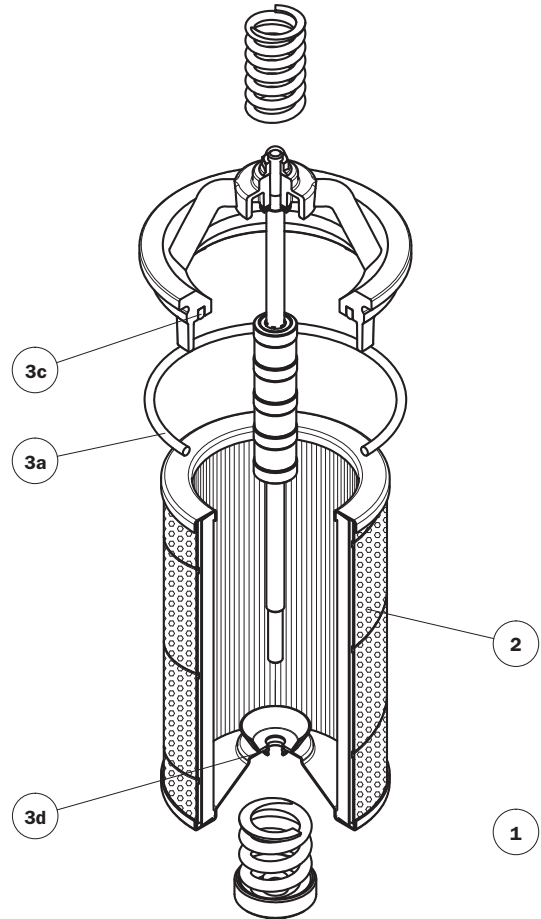

Item	Description	Q.ty	FILTER Series MPI 250		FILTER Series MPI 630	
			NBR	FPM	NBR	FPM
1	Filter assembly	1	See order table		See order table	
2	Filter element	1	See order table		See order table	
3	Seal Kit	1	02050147	02050148	02050112	02050113
3a	Insert assembly external seal	1	O-R 4437 Ø 110,70 x 3,53		O-R 210 Ø 133,40 x 5,34	
3b	Diffuser seal	1	O-R 210 Ø 133,40 x 5,34		O-R 6645 Ø 164,47 x 5,33	
3c	Insert assembly internal seal	1	01026217	01026220	01026228	01026229
3d	Filter element seal	1	O-R 112 Ø 9,92 x 2,62		O-R 112 Ø 9,92 x 2,62	

Spare parts

With diffuser

Without diffuser

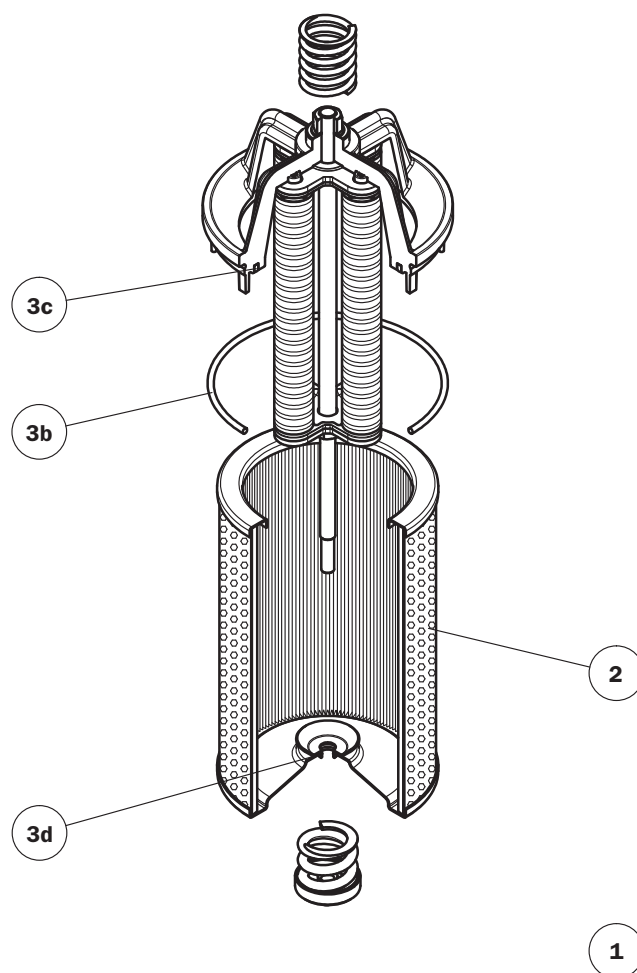
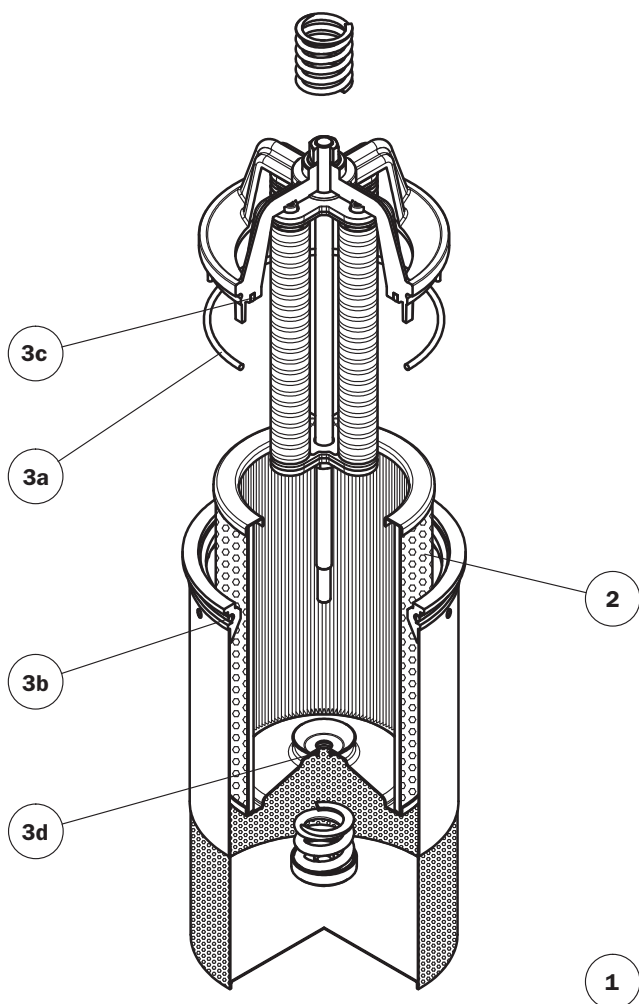

Item	Description	Q.ty	FILTER Series MPI 850	
1	Filter assembly	1	See order table	
2	Filter element	1	See order table	
3	Seal Kit	1	NBR 02050114	FPM 02050115
3a	Insert assembly external seal	1	O-R Metric Ø 209,30 x 5,7	
3b	Diffuser seal	1	O-R 8925 Ø 234,30 x 6,99	
3c	Insert assembly internal seal	1	01026248	01026249
3d	Filter element seal	1	O-R 117 Ø 13,10 x 2,62	

Ordering information MPI

Filter assembly

MPI

Example: MPI

1	2	3	4	5	6	7
<input type="text"/>	<input type="text"/>	<input type="text"/>	<input type="text"/>	<input type="text"/>	<input type="text"/>	<input type="text"/>
100	1	C	D	A	A25	P01

Filter element

MR

Example: MR

1	2	6	5	7
<input type="text"/>	<input type="text"/>	<input type="text"/>	<input type="text"/>	<input type="text"/>
100	1	A25	A	P01

1 - Style

Filter

Filter element

2 - Filter length

<input type="text" value="1"/>	<input type="text" value="2"/>	<input type="text" value="3"/>	<input type="text" value="4"/>	<input type="text" value="5"/>
<input type="text" value="1"/>	<input type="text" value="2"/>	<input type="text" value="3"/>	<input type="text" value="4"/>	
<input type="text" value="1"/>	<input type="text" value="2"/>	<input type="text" value="3"/>	<input type="text" value="4"/>	<input type="text" value="5"/>
<input type="text" value="1"/>	<input type="text" value="2"/>	<input type="text" value="3"/>	<input type="text" value="4"/>	

3 - By-pass valve

Without bypass
 1,75 bar
 2,5 bar (not available for filter MPI 850)

4 - Execution

Without diffuser and with magnetic column
 With diffuser and with magnetic column
 Without diffuser and without magnetic column
 With diffuser and without magnetic column

5 - Filter seals & Treatment

NBR
 FPM
 NBR, Insert assembly anodized.
 Filter element compatible with fluid HFA, HFB, HFC
 (only for filter element type Axx and Mxx)
 FPM, Insert assembly anodized.
 Filter element compatible with fluid HFA, HFB, HFC
 (only for filter element type Axx and Mxx)

6 - Filter element

<input type="text" value="A03"/>	Inorganic microfibre 6 μ	} Absolute filtration $\beta_x(c) \geq 1000$
<input type="text" value="A10"/>	Inorganic microfibre 10 μ	
<input type="text" value="A25"/>	Inorganic microfibre 25 μ	
<input type="text" value="M25"/>	Wire mesh	} Nominal Filtration
<input type="text" value="M60"/>	Wire mesh	
<input type="text" value="M90"/>	Wire mesh	
<input type="text" value="P10"/>	Resin impregnated paper	} Nominal Filtration
<input type="text" value="P25"/>	Resin impregnated paper	

7 - Option

MP Filtri standard

MPT

Multifunction

Multipoint



Maximum pressure 8 bar
Flow rates to 300 l/min

Filter housing (Materials)

- Head: Aluminium
- Cover: Nylon
- Bowl: Nylon

Pressure

- Working pressure: 8 bar

Temperature

- From -25 °C to +110 °C

Bypass valve

- Opening pressure 1.75 bar ±10%
- Opening pressure 3 bar ±10%

Δp Elements type

- Series N and H elements: 10 bar
- Oil flow from outside to inside.

Seals

- Standard NBR series A
- Optional FPM series V

MPT FILTERS ARE PROVIDED FOR VERTICAL MOUNTING

Weights (kg)

Length	1	2	3	4
• MPT 025	0,41	0,45	0,50	-
• MPT 027	0,44	0,48	0,55	-
• MPT 101	1,00	1,05	1,15	1,40
• MPT 104	1,10	1,15	1,25	1,50
• MPT 110-120	1,00	1,05	1,15	1,40
• MPT 114	1,10	1,15	1,25	1,50

Volumes (dm³)

Length	1	2	3	4
• MPT 025	0,24	0,35	0,42	-
• MPT 027	0,24	0,35	0,42	-
• MPT 101	0,72	0,93	1,28	1,74
• MPT 104	0,72	0,93	1,28	1,74
• MPT 110-120	0,72	0,93	1,28	1,74
• MPT 114	0,72	0,93	1,28	1,74

Compatibility (to ISO 2943)

- Housings compatible with:
Mineral oils, synthetic fluids.
Aqueous emulsions, water and glycol (series W required).
- The filter elements are compatible with:
Mineral oils, synthetic fluids.
Aqueous emulsions, water and glycol (series W required).
- NBR seals series A, compatible with:
Mineral oils, synthetic fluids.
Aqueous emulsions, water and glycol.
- FPM seals V series, compatible with:
Synthetic fluids type HS-HFDR-HFDS-HFDU

Filter housings Δp pressure drop

The curves are plotted utilising mineral oil with density of 0.86 kg/dm³ to ISO 3968.

Δp varies proportionally with density.

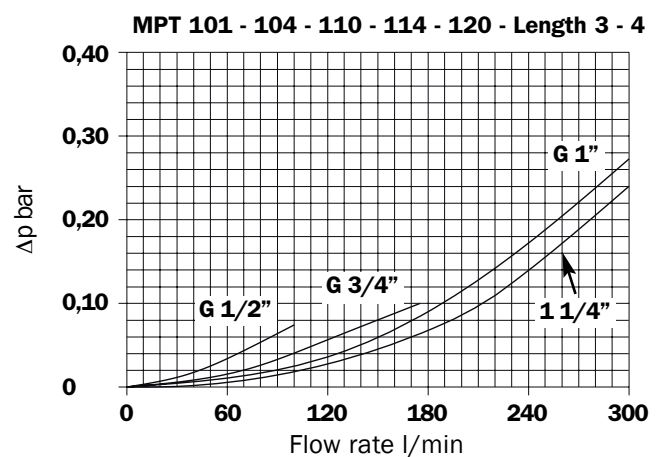
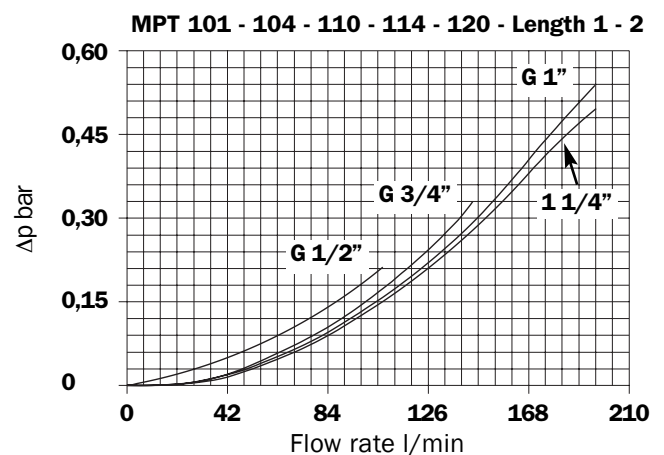
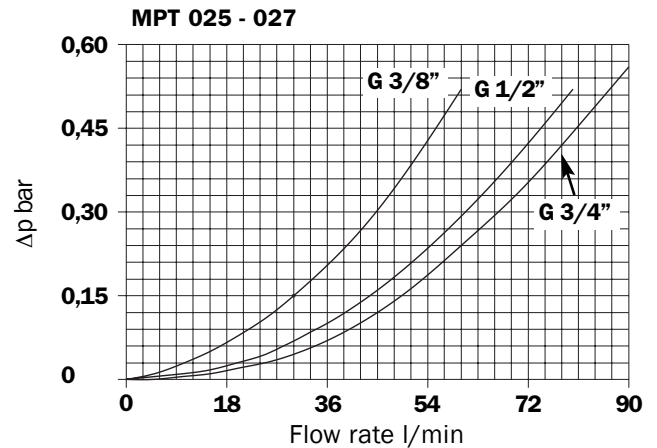

Valves

Bypass valve pressure drop

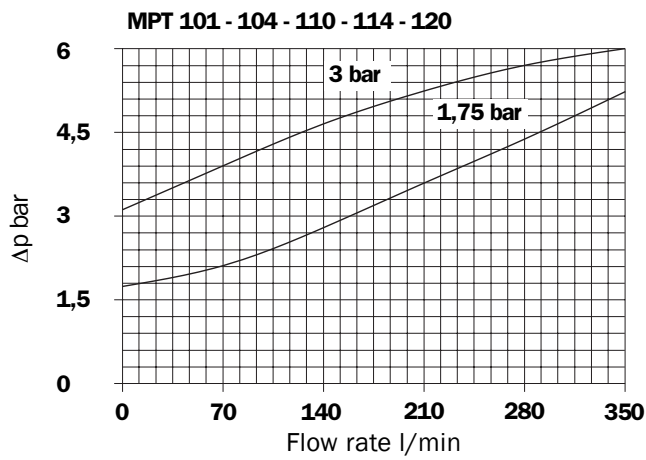
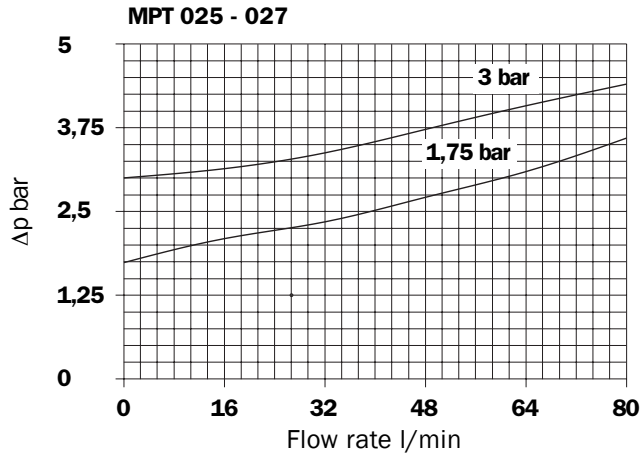

Air breather

Pressure drop

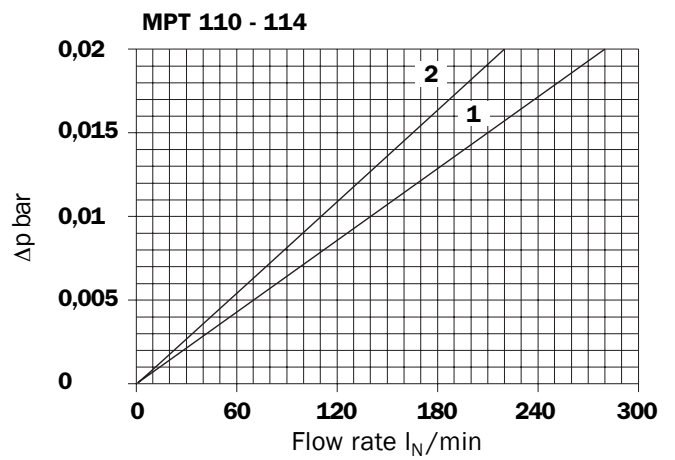
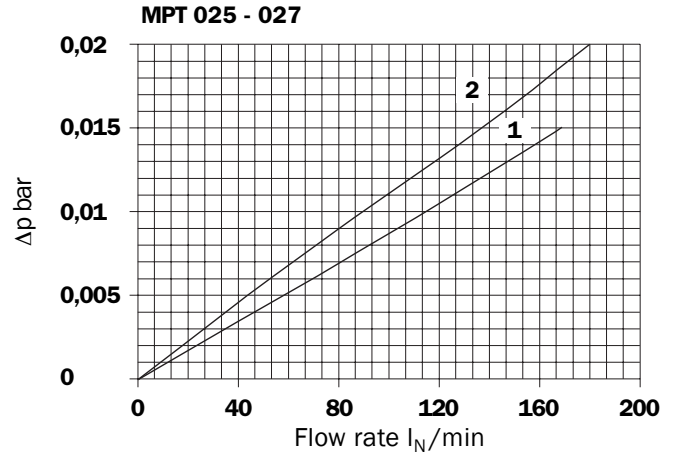

- 1: C With air breather 10 μ
- 2: D With anti-splash and SAP50 10 μ

Recommended maximum flow rate

- Pressure drop of filter assembly equal to Δp 0,5 bar.
- Oil kinematic viscosity 30 mm²/s (cSt).
- Density 0,86 kg/dm³.

Filtration

	Length	A03	A06	A10	A16	A25	P10	P25	M25 - M60 - M90	
MPT 025 - 027	1	6	9	23	28	42	50	54	110	
	2	16	19	45	48	55	64	67	110	
	3	21	24	50	55	59	70	75	110	
MPT 101 - 104	1	17	20	53	56	64	86	94	290	
	110 - 114	2	28	38	64	75	95	110	120	290
	120	3	47	53	125	135	168	220	250	290
		4	80	88	180	185	195	260	280	290

Flow rate l/min

MPT 110



Multiport - Multifunction
Standard
Single In Port



Multiport - Multifunction
Double In Port
Double Indicator Port



Multiport - Multifunction
Double In Port
Option: Drain Port
Indicator Port



Multiport - Multifunction
Double In Port
Option: Double Drain Port

MPT 120



Multiport - Multifunction
Triple In Port
Option: Double Drain Port

MPT 025 - 027



Multifunction
Air breather Port plugged
Indicator Port



Multifunction
Air breather standard
Indicator Port



Multifunction
Air breather anti-splash & pressurized
Double Indicator Port

Dimensions

MPT 025

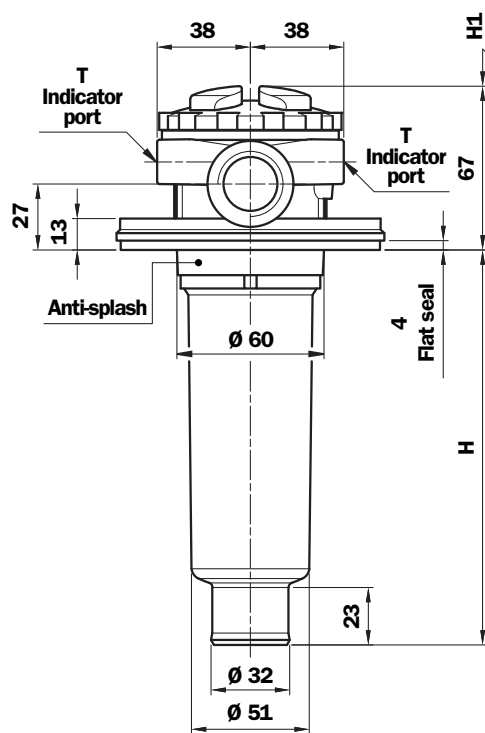

Version "S"
Without air breather

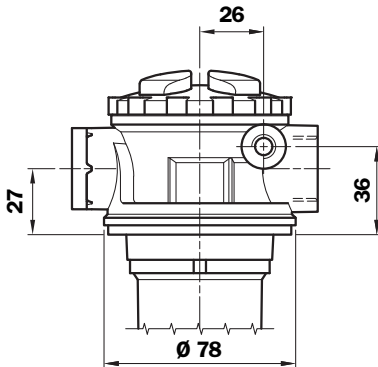

Version "C"
With air breather

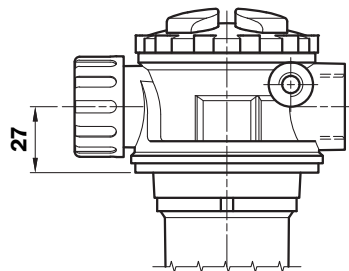

Version "D" and "P"
Anti-splash and SAP50

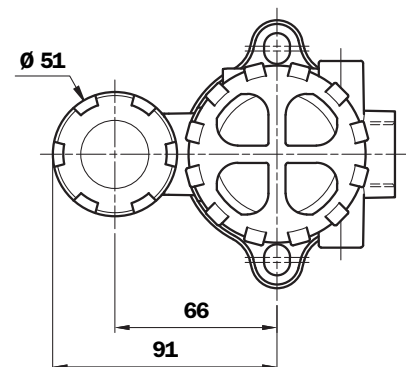
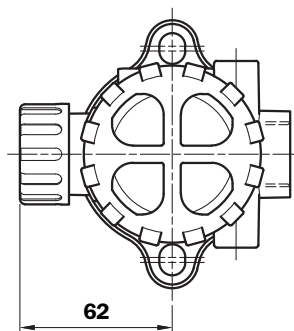
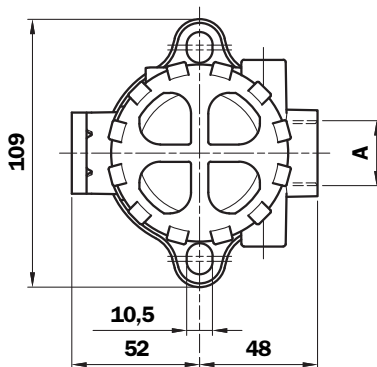
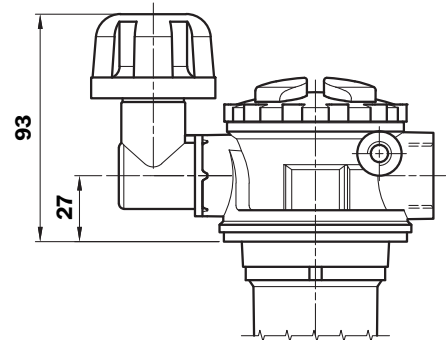

Holes on the tank

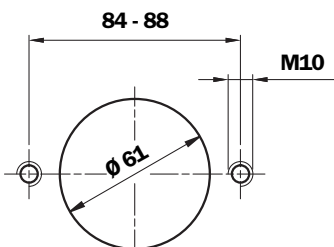

Thread connections

Type	A	T
G1	G 3/8"	G 1/8"
G2	G 1/2"	G 1/8"
G3	G 3/4"	G 1/8"
G4	3/8" NPT	1/8" NPT
G5	1/2" NPT	1/8" NPT
G6	3/4" NPT	1/8" NPT
G7	SAE 6 - 9/16" - 18 UNF	1/8" NPT
G8	SAE 8 - 3/4" - 16 UNF	1/8" NPT
G9	SAE 12 - 1 1/16" - 12 UN	1/8" NPT

Filter Length	H mm	H1 mm
1	99	130
2	163	195
3	202	230

MPT 027

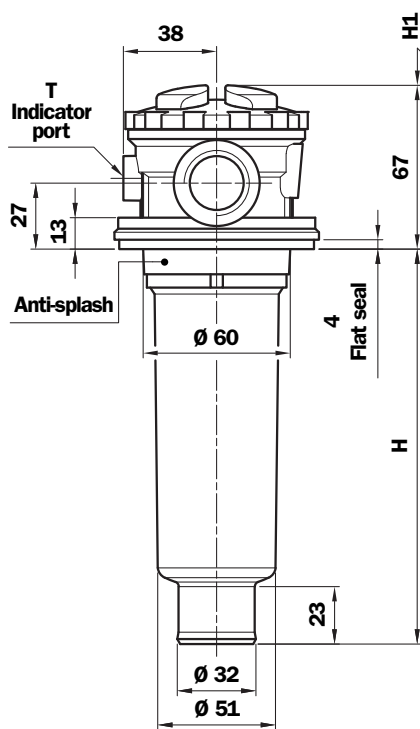

Version "S"
Without air breather

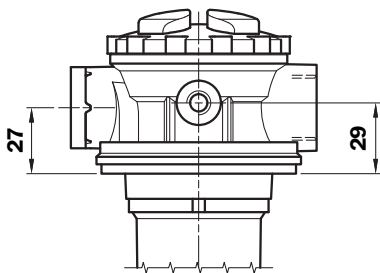

Version "C"
With air breather

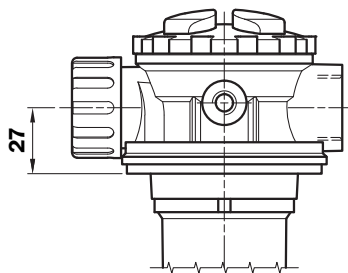

Version "D" and "P"
Anti-splash and SAP50

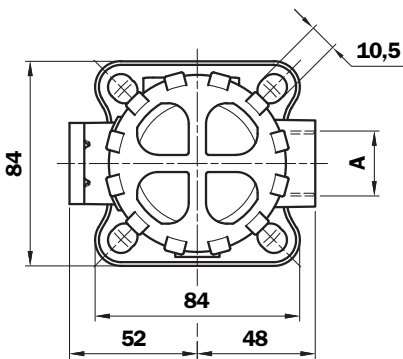
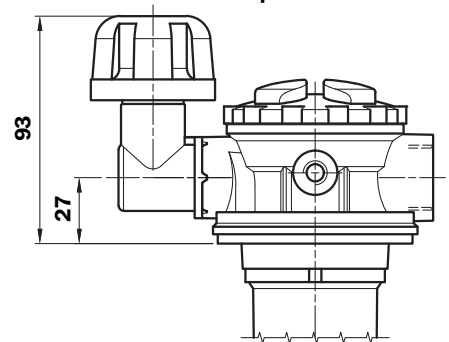

Holes on the tank

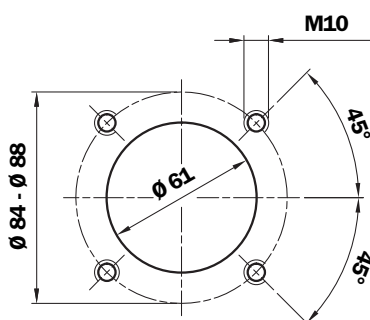
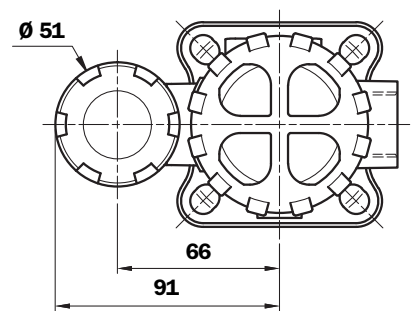
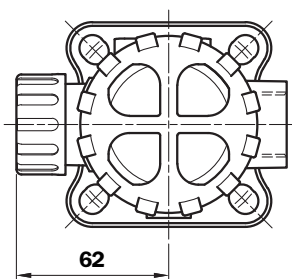

Thread connections

Type	A	T
G1	G 3/8"	G 1/8"
G2	G 1/2"	G 1/8"
G3	G 3/4"	G 1/8"
G4	3/8" NPT	1/8" NPT
G5	1/2" NPT	1/8" NPT
G6	3/4" NPT	1/8" NPT
G7	SAE 6 - 9/16" - 18 UNF	1/8" NPT
G8	SAE 8 - 3/4" - 16 UNF	1/8" NPT
G9	SAE 12 - 1 1/16" - 12 UN	1/8" NPT

Filter Length	H mm	H1 mm
1	99	130
2	163	195
3	202	230

MPT 101

Without air breather

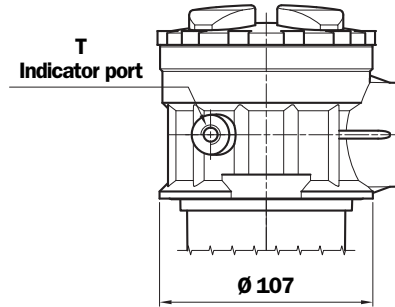
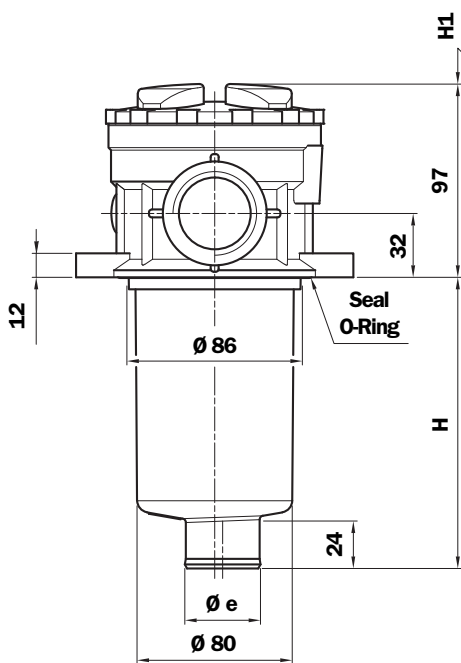

Holes on the tank

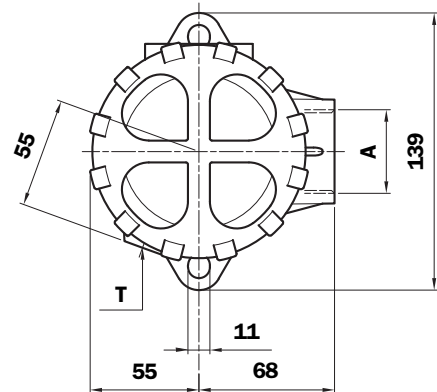
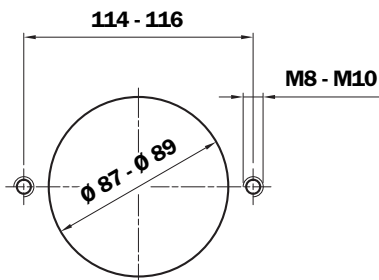

Thread connections

Type	A	T
G1	G 3/4"	G 1/8"
G2	G 1"	G 1/8"
G3	G 1 1/4"	G 1/8"
G4	3/4" NPT	1/8" NPT
G5	1" NPT	1/8" NPT
G6	1 1/4" NPT	1/8" NPT
G7	SAE 12 - 1 1/16" - 12 UN	1/8" NPT
G8	SAE 16 - 1 5/16" - 12 UN	1/8" NPT
G9	SAE 20 - 1 5/8" - 12 UN	1/8" NPT

T indicator port
G 1/4" - 1/4" NPT
ON REQUEST

Filter Length	H mm	H1 mm	Ø e mm
1	99	120	38
2	146	170	38
3	224	250	46,5
4	326	350	46,5

MPT 104

Without air breather

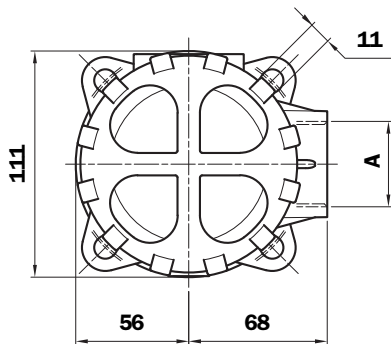
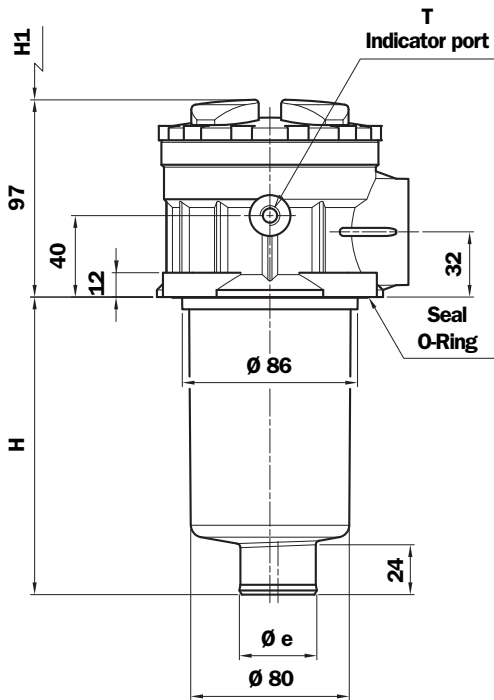

Holes on the tank

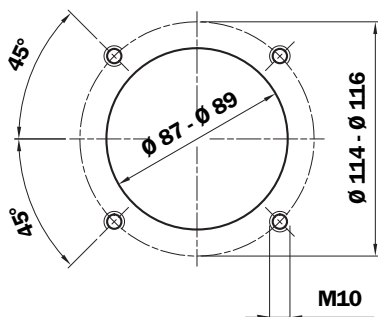

T indicator port
G 1/4" - 1/4" NPT
ON REQUEST

Thread connections

Type	A	T
G1	G 3/4"	G 1/8"
G2	G 1"	G 1/8"
G3	G 1 1/4"	G 1/8"
G4	3/4" NPT	1/8" NPT
G5	1" NPT	1/8" NPT
G6	1 1/4" NPT	1/8" NPT
G7	SAE 12-1 1/16" - 12 UN	1/8" NPT
G8	SAE 16-1 5/16" - 12 UN	1/8" NPT
G9	SAE 20-1 5/8" - 12 UN	1/8" NPT

Filter Length	H mm	H1 mm	Ø e mm
1	99	120	38
2	146	170	38
3	224	250	46,5
4	326	350	46,5

MPT 110

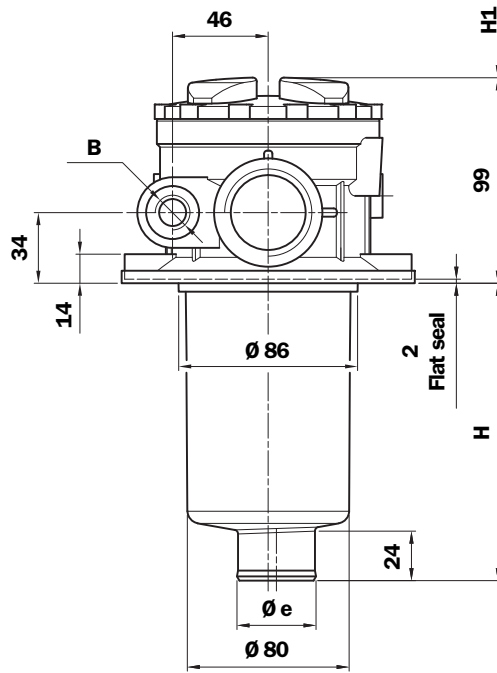

Version "S"
Without air breather

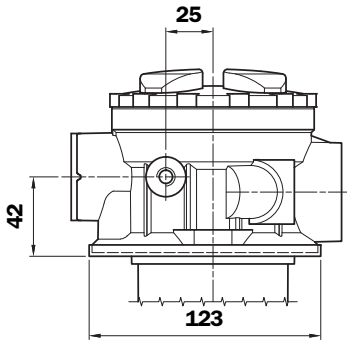

Version "C"
With air breather

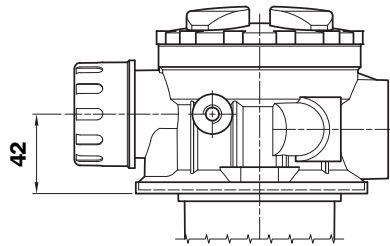

Version "D" and "P"
Anti-splash and SAP50

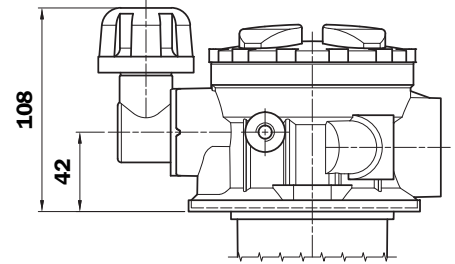

T Indicator port

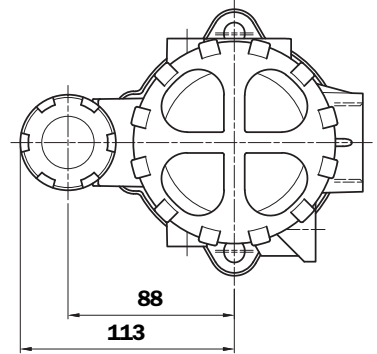
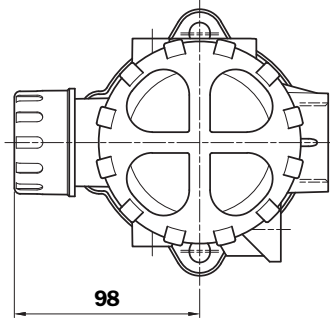
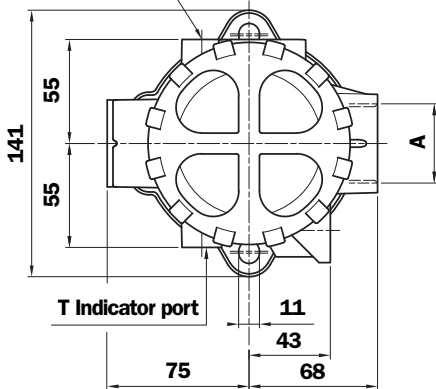

Holes on the tank

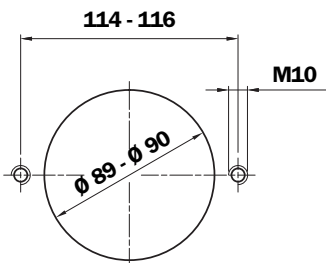

Filter Length	H mm	H1 mm	Ø e mm
1	97	120	38
2	144	170	38
3	222	250	46,5
4	324	350	46,5

T indicator port
G 1/4" - 1/4" NPT
ON REQUEST

Thread connections A	Thread connections B		
	0	1	2
G1 - G2 - G3	not machined	G 3/8"	G 1/2"
G4 - G5 - G6	not machined	3/8" NPT	1/2" NPT
G7 - G8 - G9	not machined	SAE 6 - 9/16" - 18 UNF	SAE 8 - 3/4" - 16 UNF

Thread connections A

Type	A	T
G1	G 3/4"	G 1/8"
G2	G 1"	G 1/8"
G3	G 1 1/4"	G 1/8"
G4	3/4" NPT	1/8" NPT
G5	1" NPT	1/8" NPT
G6	1 1/4" NPT	1/8" NPT
G7	SAE 12 - 1 1/16" - 12 UN	1/8" NPT
G8	SAE 16 - 1 5/16" - 12 UN	1/8" NPT
G9	SAE 20 - 1 5/8" - 12 UN	1/8" NPT

MPT 114

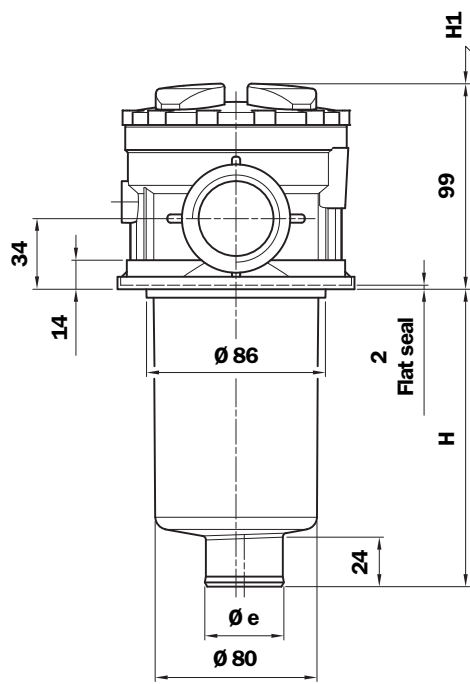

Version "S"
Without air breather

Version "C"
With air breather

Version "D" and "P"
Anti-splash and SAP50

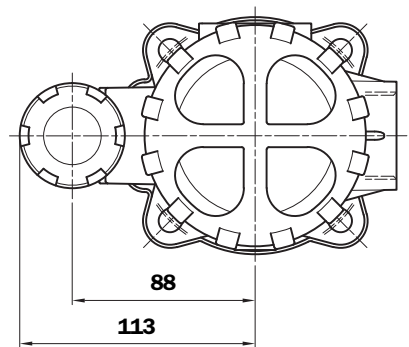
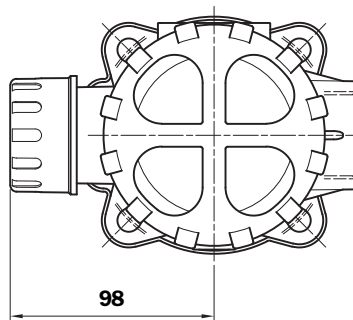
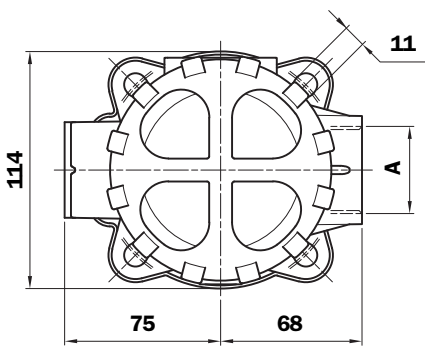
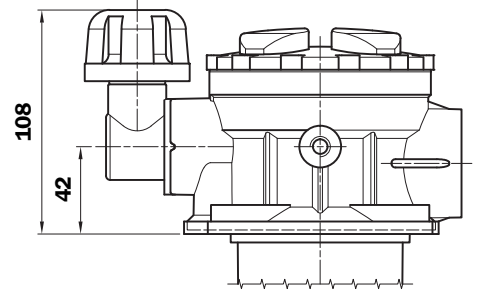
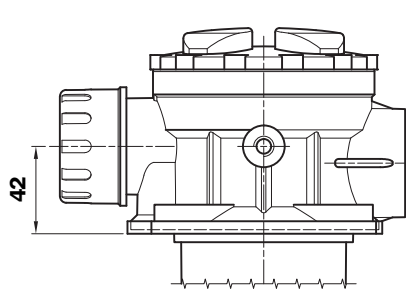
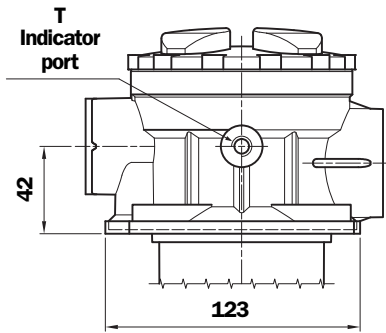

Holes on the tank

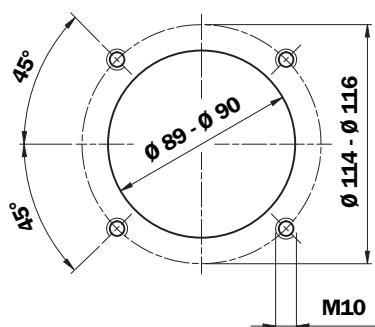

Filter Length	H mm	H1 mm	Ø e mm
1	97	120	38
2	144	170	38
3	222	250	46,5
4	324	350	46,5

T indicator port
G 1/4" - 1/4" NPT
ON REQUEST

Thread connections A

Type	A	T
G1	G 3/4"	G 1/8"
G2	G 1"	G 1/8"
G3	G 1 1/4"	G 1/8"
G4	3/4" NPT	1/8" NPT
G5	1" NPT	1/8" NPT
G6	1 1/4" NPT	1/8" NPT
G7	SAE 12 - 1 1/16" - 12 UN	1/8" NPT
G8	SAE 16 - 1 5/16" - 12 UN	1/8" NPT
G9	SAE 20 - 1 5/8" - 12 UN	1/8" NPT

MPT 120

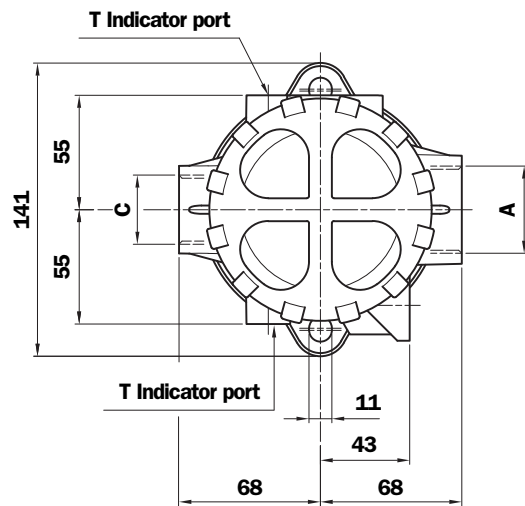
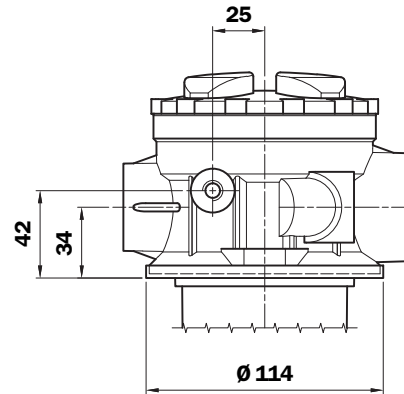
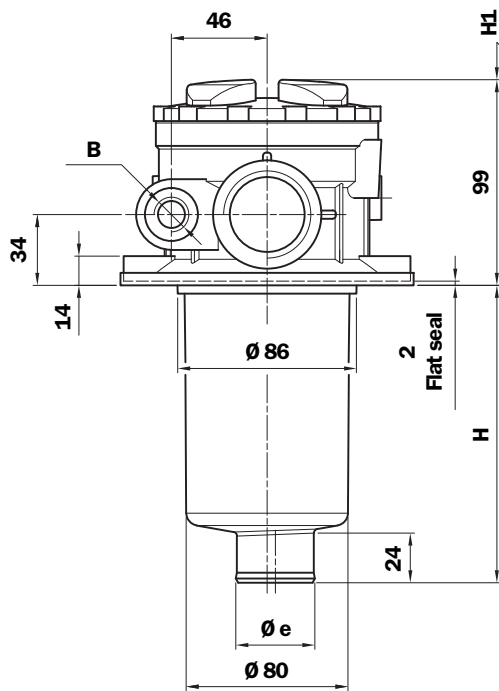

Holes on the tank

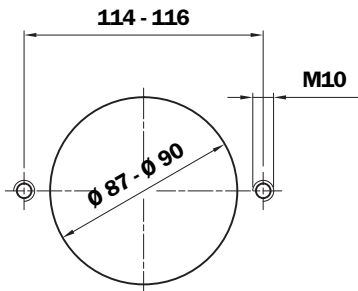

Thread connections A and C

Type	A	C	T
G1	G 3/4"	G 3/4"	G 1/8"
G2	G 1"	G 1"	G 1/8"
G3	G 1 1/4"	G 3/4"	G 1/8"
G4	3/4" NPT	3/4" NPT	1/8" NPT
G5	1" NPT	1" NPT	1/8" NPT
G6	1 1/4" NPT	3/4" NPT	1/8" NPT
G7	SAE 12 - 1 1/16" - 12 UN	SAE 12 - 1 1/16" - 12 UN	1/8" NPT
G8	SAE 16 - 1 5/16" - 12 UN	SAE 16 - 1 5/16" - 12 UN	1/8" NPT
G9	SAE 20 - 1 5/8" - 12 UN	SAE 12 - 1 1/16" - 12 UN	1/8" NPT

Filter Length	H mm	H1 mm	Ø e mm
1	97	120	38
2	144	170	38
3	222	250	46,5
4	324	350	46,5

T indicator port
G 1/4" - 1/4" NPT
ON REQUEST

Thread connections A	Thread connections B		
	0	1	2
G1 - G2 - G3	not machined	G 3/8"	G 1/2"
G4 - G5 - G6	not machined	3/8" NPT	1/2" NPT
G7 - G8 - G9	not machined	SAE 6 - 9/16" - 18 UNF	SAE 8 - 3/4" - 16 UNF

Spare parts

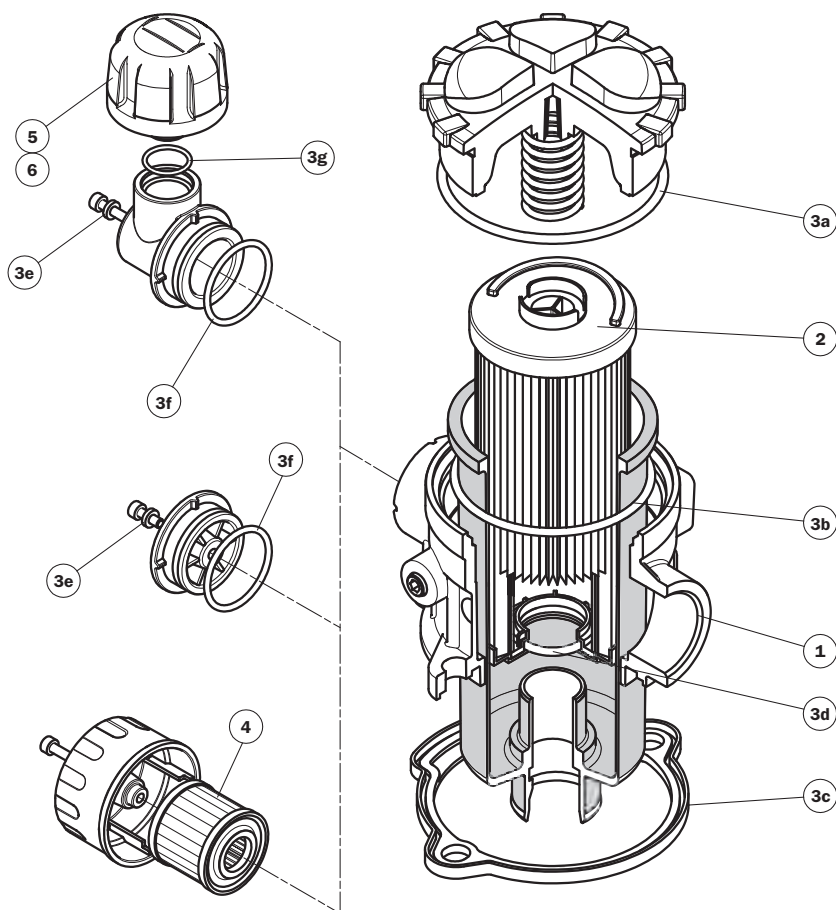

Item	Description	Q.ty	FILTER Series					
			MPT 025		MPT 027		MPT 110	
1	Filter assembly	1	See order table					
2	Filter element	1	See order table					
3	Seal Kit	1	NBR 02050557	FPM 02050558	NBR 02050559	FPM 02050560	NBR 02050561	FPM 02050562
3a	Cover seal	1	O-R Metric Ø 59 x 3		O-R Metric Ø 59 x 3		O-R Metric Ø 90 x 4	
3b	Bowl seal	1	O-R 3200 Ø 50,47 x 2,62		O-R 3200 Ø 50,47 x 2,62		O-R 4312 Ø 78,97 x 3,53	
3c	Head seal	1	01026268	01026298	01026260	01026343	01026351	01026352
3d	Filter element seal	1	Length 1-2	O-R 4087 Ø 21,82 x 3,53	Length 1-2	O-R 4087 Ø 21,82 x 3,53	Length 1-2	O-R 4112 Ø 28,17 x 3,53
			Length 3	O-R 3081 Ø 20,24 x 2,62	Length 3	O-R 3081 Ø 20,24 x 2,62	Length 3-4	O-R 4162 Ø 40,86 x 3,53
3e	Air breather screw seal	1	01026346	01026347	01026346	01026347	01026346	01026347
3f	Plug - Anti-splash seal	1	O-R 130 Ø 22,22 x 2,62		O-R 130 Ø 22,22 x 2,62		O-R 3131 Ø 32,99 x 2,62	
3g	SAP50 seal	1	O-R 2068 Ø 17,17 x 1,78		O-R 2068 Ø 17,17 x 1,78		O-R 2068 Ø 17,17 x 1,78	
4	Air breather filter element "C" version	1	10 micron A3L03		10 micron A3L03		10 micron A3L03	
5	Air breather filter element "D" version	1	10 micron SAP50G3L03A0P01		10 micron SAP50G3L03A0P01		10 micron SAP50G3L03A0P01	
6	Air breather filter element "P" version	1	10 micron SAP50G3L03A1P01		10 micron SAP50G3L03A1P01		10 micron SAP50G3L03A1P01	

Spare parts

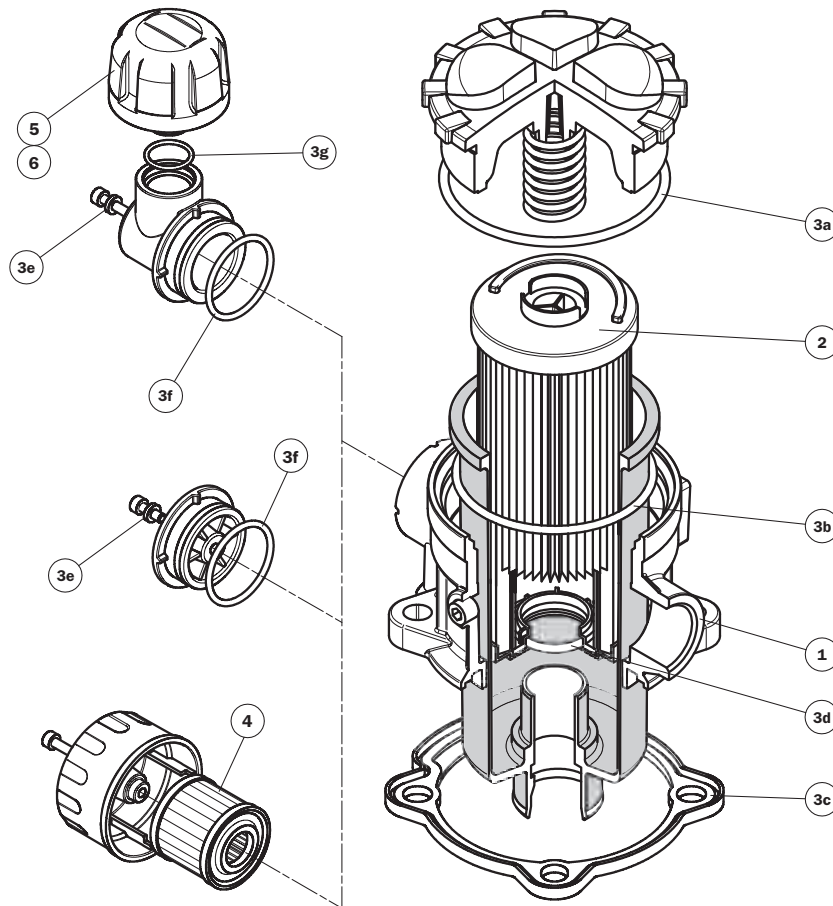

Item	Description	Q.ty	FILTER Series MPT 114	
1	Filter assembly	1	See order table	
2	Filter element	1	See order table	
3	Seal Kit	1	NBR 02050580	FPM 02050581
3a	Cover seal	1	O-R Metric Ø 90 x 4	
3b	Bowl seal	1	O-R 4312 Ø 78,97 x 3,53	
3c	Head seal	1	01026371	01026372
3d	Filter element seal	1	Length 1-2 Ø 28,17 x 3,53	O-R 4112
			Length 3-4 Ø 40,86 x 3,53	O-R 4162
3e	Air breather screw seal	1	01026346	01026347
3f	Plug - Anti-splash seal	1	O-R 3131 Ø 32,99 x 2,62	
3g	SAP50 seal	1	O-R 2068 Ø 17,17 x 1,78	
4	Air breather filter element "C" version	1	10 micron A3L03	
5	Air breather filter element "D" version	1	10 micron SAP50G3L03A0P01	
6	Air breather filter element "P" version	1	10 micron SAP50G3L03A1P01	

Spare parts

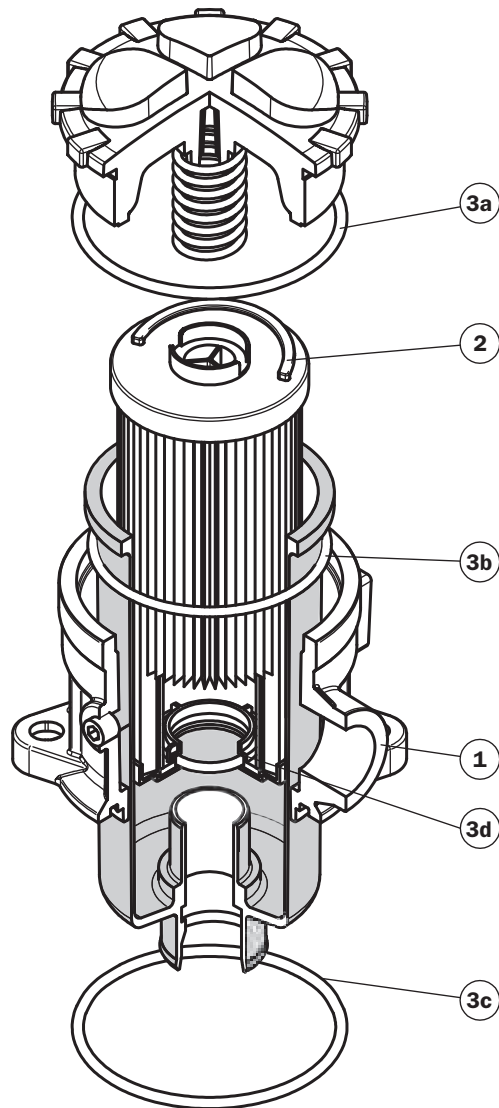

Item	Description	Q.ty	FILTER Series	
			MPT 101 S / 104 S	
1	Filter assembly	1	See order table	
2	Filter element	1	See order table	
3	Seal Kit	1	NBR 02050466	FPM 02050467
3a	Cover seal	1	O-R Metric Ø 90 x 4	
3b	Bowl seal	1	O-R 4312 Ø 78,97 x 3,53	
3c	Head seal	1	O-R Metric Ø 90 x 4	
3d	Filter element seal	1	Length 1-2	O-R 4112 Ø 28,17 x 3,53
			Length 3-4	O-R 4162 Ø 40,86 x 3,53

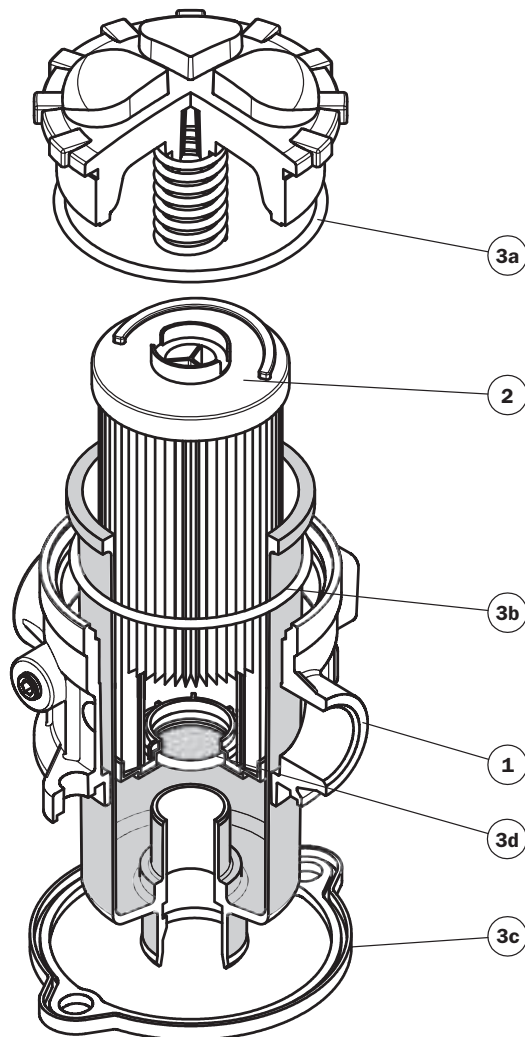

Item	Description	Q.ty	FILTER Series MPT 120	
1	Filter assembly	1	See order table	
2	Filter element	1	See order table	
3	Seal Kit	1	NBR 02050563	FPM 02050564
3a	Cover seal	1	O-R Metric Ø 90 x 4	
3b	Bowl seal	1	O-R 4312 Ø 78,97 x 3,53	
3c	Head seal	1	01026361	01026362
3d	Filter element seal	1	Length 1-2	O-R 4112 Ø 28,17 x 3,53
			Length 3-4	O-R 4162 Ø 40,86 x 3,53

Ordering information MPT 025-027-101-104-114

Filter assembly

MPT

	1	2	3	4	5	6	9	10
Example 1: MPT	025	2	D	A	G3	A06	E	P01
Example 2: MPT	104	4	S	A	G1	M60	B	P01

Filter element

MF

	1	2	6	7	8	9	10
Example 1: MF	020	2	A06	H	B	E	P01
Example 2: MF	100	4	M60	N	B		P01

1 - Style

Filter	Filter element
025	020
027	020
101	100
104	100
114	100

2 - Filter length

025	1	2	3	
027	1	2	3	
101	1	2	3	4
104	1	2	3	4
114	1	2	3	4

3 - Air breather

S	Without air breather
C	(1) With air breather 10 μ
D	(1) Anti-splash and SAP50 10 μ air breather
P	(1) Anti-splash, SAP50 10 μ air breather and pressurization 0,5 bar

(1) Excluded MPT 101 - 104

4 - Filter seals & Treatment

A	NBR
V	FPM
W	NBR, Head anodized - filter element compatible with fluid HFA, HFB, HFC (only for filter element type Axx and Mxx)
Z	FPM, Head anodized - filter element compatible with fluid HFA, HFB, HFC (only for filter element type Axx and Mxx)

5 - Connections

Type	MPT 025-027	MPT 101-104-114
G1	G 3/8"	G 3/4"
G2	G 1/2"	G 1"
G3	G 3/4"	G 1 1/4"
G4	3/8" NPT	3/4" NPT
G5	1/2" NPT	1" NPT
G6	3/4" NPT	1 1/4" NPT
G7	SAE 6 - 9/16" - 18 UNF	SAE 12 - 1 1/16" - 12 UN
G8	SAE 8 - 3/4" - 16 UNF	SAE 16 - 1 5/16" - 12 UN
G9	SAE 12 - 1 1/16" - 12 UN	SAE 20 - 1 5/8" - 12 UN

6 - Filter element

A03	Inorganic microfibre 3 μ	Absolute filtration $\beta_x(c) \geq 1000$
A06	Inorganic microfibre 6 μ	
A10	Inorganic microfibre 10 μ	
A16	Inorganic microfibre 16 μ	
A25	Inorganic microfibre 25 μ	
M25	Wire mesh	Nominal Filtration
M60	Wire mesh	
M90	Wire mesh	
P10	Resin impregnated paper	Nominal Filtration
P25	Resin impregnated paper	

7 - Δp Filter element

N	Δp 10 bar (only for filter element type Pxx and Mxx)
H	Δp 10 bar (only for filter element type Axx)
W*	Δp 10 bar (only for filter element type Axx and Mxx)

8 - Filter element seals

B	NBR
V	FPM

9 - By-pass valve

E	3 bar
B	1.75 bar (Omit in the element code - only for 1.75 bar)

10 - Option

P01	MP Filtri standard
------------	--------------------

* Compatible with fluid HFA, HFB, HFC

MP Filtri - The filter functions as described in this bulletin are valid exclusively for original MP Filtri filter elements and replacement parts. All rights reserved

The data in this publication are purely guideline. MP Filtri reserves the right to make changes to the models described herein at any time it deems fit in relation to technical or commercial requirements. The colours of the products shown on the cover are purely guideline. Copyright. All rights reserved.

Ordering information MPT 110-120

Filter assembly

MPT

	1	2	3	4	5	6	7	10	11
Example 1: MPT	110	2	C	A	G3	2	A06	E	P01
Example 2: MPT	120	3		A	G3	1	P10	B	P01

Filter element

MF

	1	2	7	8	9	10	11
Example 1: MF	100	2	A06	H	B	E	P01
Example 2: MF	100	3	P10	N	B		P01

1 - Style

Filter	Filter element
110	100
120	100

2 - Filter length

110	1	2	3	4
120	1	2	3	4

3 - Air breather (omit for MPT 120)

S	Without air breather
C	With air breather 10 μ
D	Anti-splash and SAP50 10 μ air breather
P	Anti-splash and SAP50 10 μ air breather pressurization 0,5 bar

4 - Filter seals & Treatment

A	NBR
V	FPM
W	NBR, Head anodized - filter element compatible with fluid HFA, HFB, HFC (only for filter element type Axx and Mxx)
Z	FPM, Head anodized - filter element compatible with fluid HFA, HFB, HFC (only for filter element type Axx and Mxx)

5 - Connections A - C

MPT 110 Connections A MPT 120 Connections A and C

Type	A	C
G1	G 3/4"	G 3/4"
G2	G 1"	G 1"
G3	G 1 1/4"	G 3/4"
G4	3/4" NPT	3/4" NPT
G5	1" NPT	1" NPT
G6	1 1/4" NPT	3/4" NPT
G7	SAE 12 - 1 1/16" - 12 UN	SAE 12 - 1 1/16" - 12 UN
G8	SAE 16 - 1 5/16" - 12 UN	SAE 16 - 1 5/16" - 12 UN
G9	SAE 20 - 1 5/8" - 12 UN	SAE 12 - 1 1/16" - 12 UN

6 - Connections B

Type	Connections A		
	G1 - G2 - G3	G4 - G5 - G6	G7 - G8 - G9
0	not machined	not machined	not machined
1	G 3/8"	3/8" NPT	SAE 6 - 9/16" - 18 UNF
2	G 1/2"	1/2" NPT	SAE 8 - 3/4" - 16 UNF

7 - Filter element

A03	Inorganic microfibre 3 μ	Absolute filtration $\delta x (c) \geq 1000$
A06	Inorganic microfibre 6 μ	
A10	Inorganic microfibre 10 μ	
A16	Inorganic microfibre 16 μ	
A25	Inorganic microfibre 25 μ	
M25	Wire mesh	Nominal Filtration
M60	Wire mesh	
M90	Wire mesh	
P10	Resin impregnated paper	Nominal Filtration
P25	Resin impregnated paper	

8 - Δp Filter element

N	Δp 10 bar (only for filter element type Pxx and Mxx)
H	Δp 10 bar (only for filter element type Axx)
W*	Δp 10 bar (only for filter element type Axx and Mxx)

9 - Filter element seals

B	NBR
V	FPM

10 - By-pass valve

E	3 bar
B	1.75 bar (Omit in the element code - only for 1.75 bar)

11 - Option

P01	MP Filtri standard
------------	--------------------

* Compatible with fluid HFA, HFB, HFC

MP Filtri - The filter functions as described in this bulletin are valid exclusively for original MP Filtri filter elements and replacement parts. All rights reserved

The data in this publication are purely guideline. MP Filtri reserves the right to make changes to the models described herein at any time it deems fit in relation to technical or commercial requirements. The colours of the products shown on the cover are purely guideline. Copyright. All rights reserved.

RF2



Maximum pressure 20 bar
Flow rates to 455 l/min

Filter housing (Materials)

- Filter body: Aluminium
- Cover: Nylon
- Valve: Nylon - Steel
- Anti-Emptying valve: Steel

Pressure

- Working pressure: 20 bar

Temperature

- From -25 °C to +110 °C

Bypass valve

- Opening pressure 1,75 bar \pm 10%

Δp Elements type

- Series CU elements: 10 bar
- Oil flow from inside to outside.

Seals

- Standard NBR series A
- Optional FPM series V

Weights (kg)

- RF2 250 2,6
- RF2 350 2,8

Volumes (dm³)

- RF2 250 2,0
- RF2 350 2,0

Compatibility (to ISO 2943)

- Housings compatible with:
Mineral oils, synthetic fluids.
Aqueous emulsions, water and glycol.
- The filter elements are compatible with:
Mineral oils, synthetic fluids.
Aqueous emulsions, water and glycol
(series W required).
- NBR seals series A, compatible with:
Mineral oils, synthetic fluids.
Aqueous emulsions, water and glycol.
- FPM seals V series, compatible with:
Synthetic fluids type HS-HFDR-HFDS-HFDU

Recommended maximum flow rate

- Pressure drop of filter assembly equal to Δp 0,5 bar.
- Oil kinematic viscosity 30 mm²/s (cSt).
- Density 0,86 kg/dm³.

Filter housings Δp pressure drop

The curves are plotted utilising mineral oil with density of 0.86 kg/dm³ to ISO 3968.

Δp varies proportionally with density.

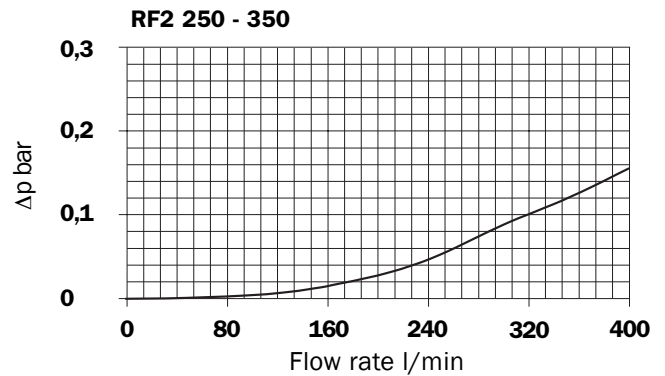

Valves

Bypass valve pressure drop

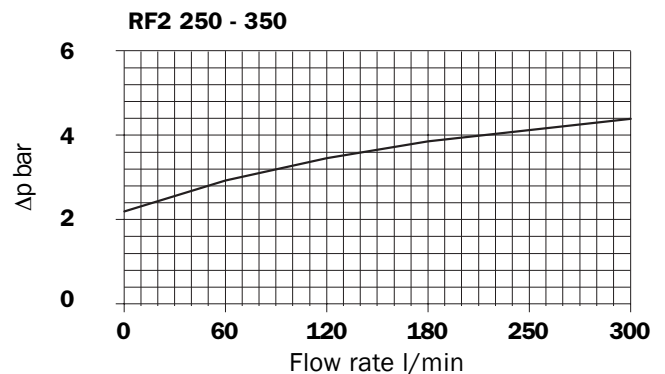

Filtration

Length	A03	A06	A10	A16	A25	P10	P25	M25 - M60 - M90
RF2 250 - 350	1	143	178	270	300	350	350	350

Flow rate l/min

Dimensions

RF2 250

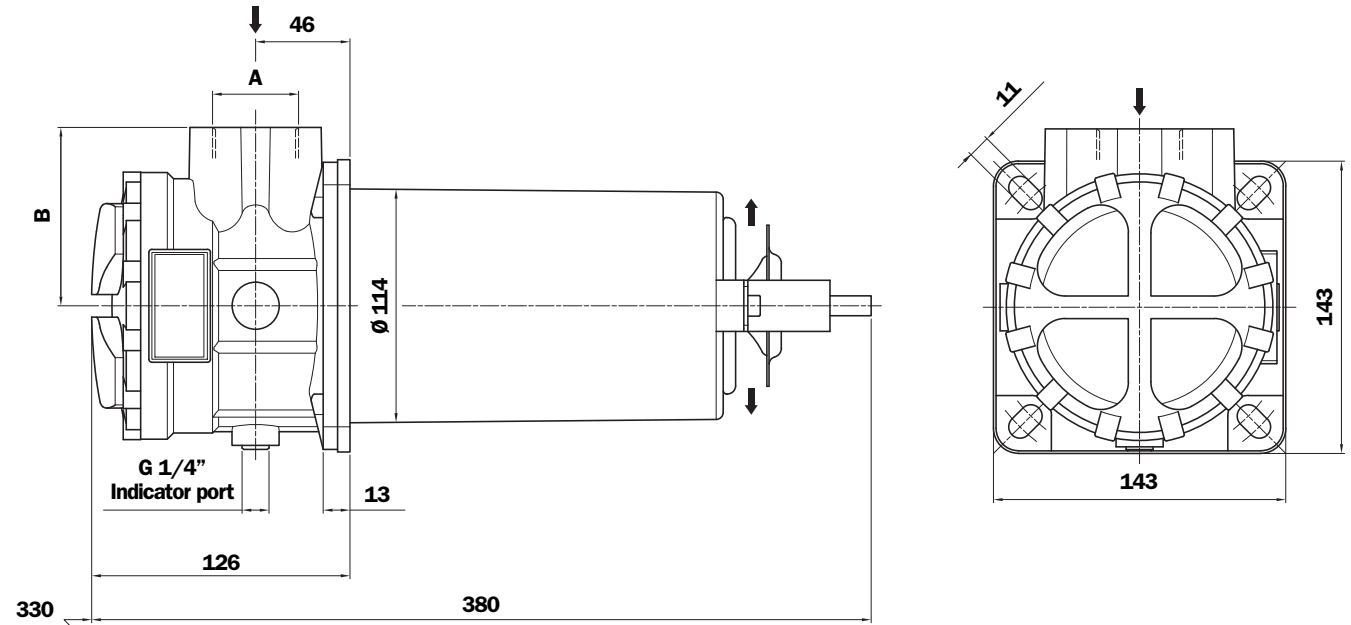

Holes on the tank

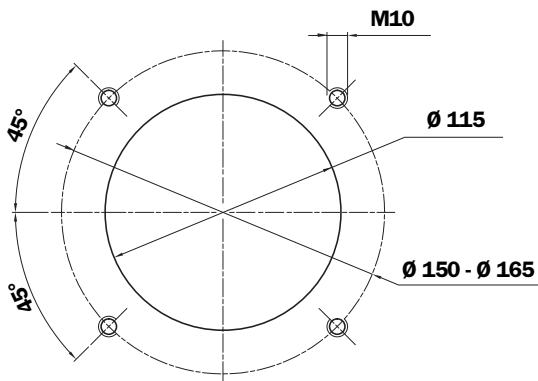

Thread connections

Type	A	B
G1	G 1 1/2"	82
G2	1 1/2" NPT	82
G3	SAE 24 - 1 7/8" - 12 UN	82
G4	G 1 1/4"	82
G5	1 1/4" NPT	82
G6	SAE 20 - 1 5/8" - 12 UN	82
G7	G 1"	82
G8	1" NPT	82
G9	SAE 16 - 1 5/16" - 12 UN	82

Flange connections*

Type	A	B
F1	1 1/2" SAE 3000 psi/M	87
F2	1 1/2" SAE 3000 psi/UNC	87

*Connections table "DN - SAE flange" see page 5

RF2 350

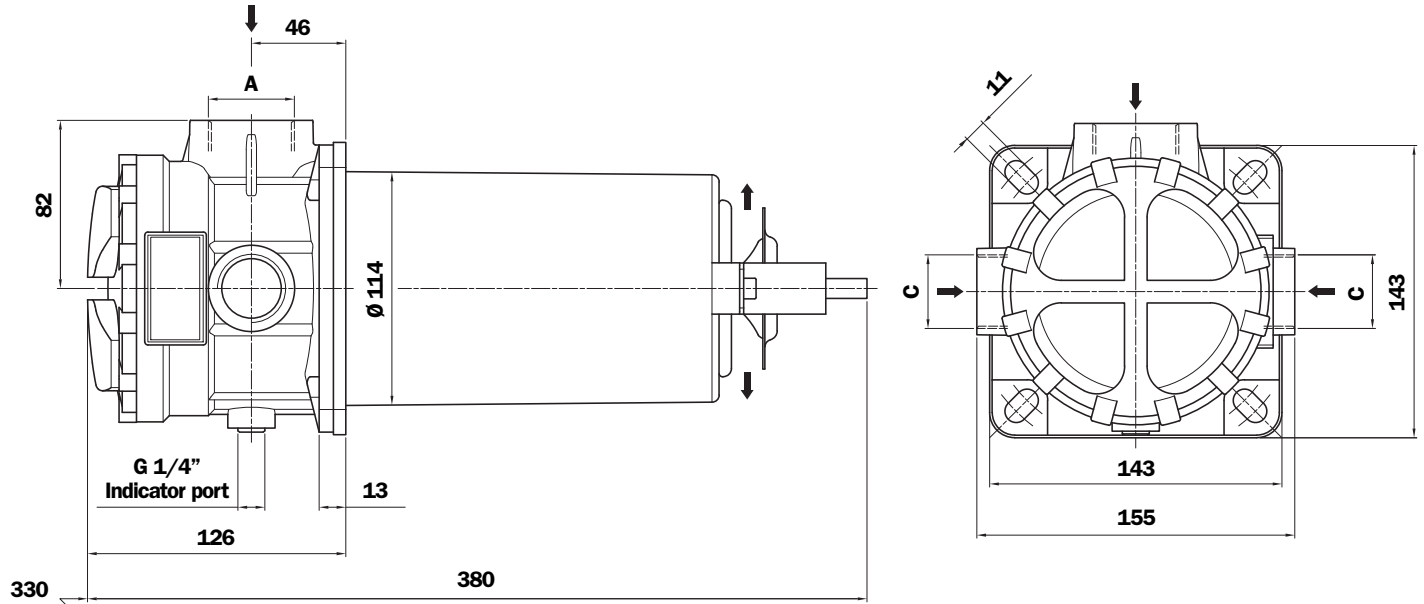

Holes on the tank

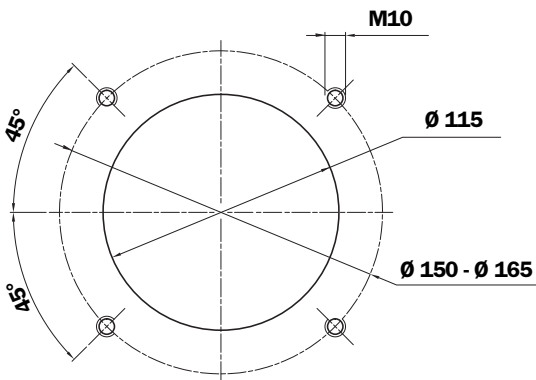

Thread connections

Type	A	C
G1	G 1 1/2"	G 1"
G3	SAE 24 - 1 7/8" - 12 UN	SAE 16 - 1 5/16" - 12 UN

Spare parts

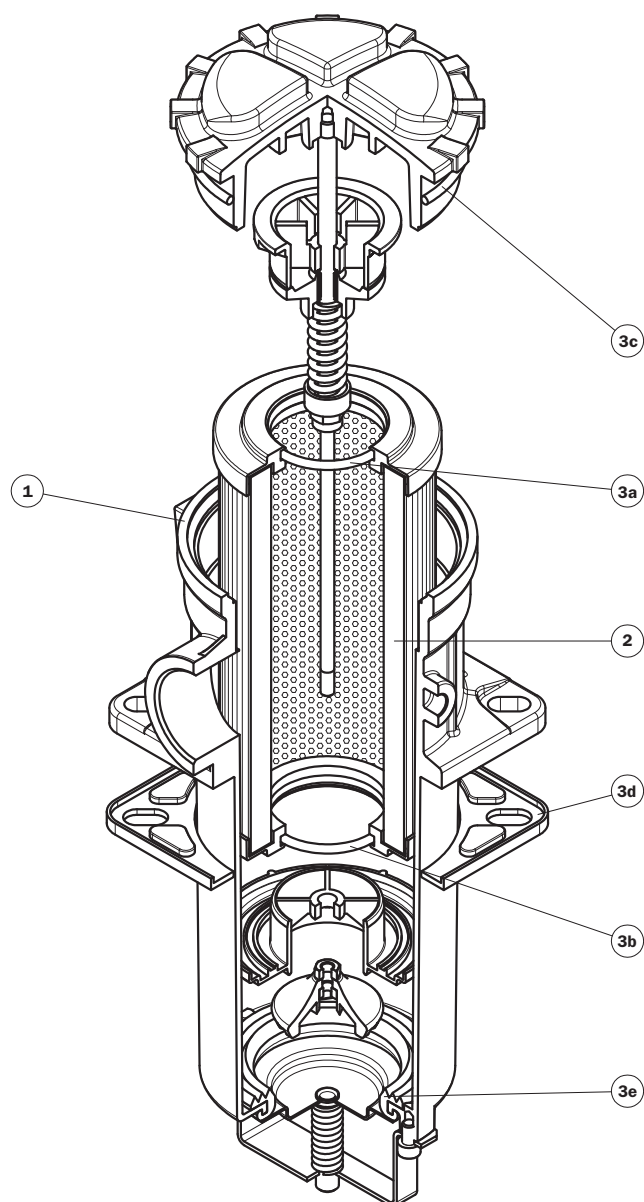

Item	Description	Q.ty	FILTER Series RF2 250 - 350	
1	Filter assembly	1	See order table	
2	Filter element	1	See order table	
3	Seal Kit	1	NBR 02050586	FPM 02050587
3a	Filter element top seal	1	O-R Metric Ø 50 x 4	
3b	Filter element bottom seal	1	O-R Metric Ø 50 x 4	
3c	Cover seal	1	O-R Metric Ø 113 x 4	
3d	Head seal	1	01026595	01026596
3e	Valve seal	1	01026209	01026210

Ordering information RF2

Filter assembly RF2

Example: RF2

1	2	3	4	5	7
<input type="text"/>	<input type="text"/>	<input type="text"/>	<input type="text"/>	<input type="text"/>	<input type="text"/>
350	A	G1	B	A25	P01

Filter element CU

Example: CU

1	5	6	7
<input type="text"/>	<input type="text"/>	<input type="text"/>	<input type="text"/>
250	A25	N	P01

1 - Style

Filter	Filter element
<input type="text" value="250"/>	<input type="text" value="250"/>
<input type="text" value="350"/>	<input type="text" value="250"/>

2 - Filter seals & Treatment

<input type="text" value="A"/>	NBR
<input type="text" value="V"/>	FPM
<input type="text" value="W"/>	NBR, Filter body anodized. Filter element compatible with fluid HFA, HFB, HFC (only for filter element type Axx and Mxx)
<input type="text" value="Z"/>	FPM, Filter body anodized. Filter element compatible with fluid HFA, HFB, HFC (only for filter element type Axx and Mxx)

3 - Connections

RF2 250

Type	A
G1	G 1 1/2"
G2	1 1/2" NPT
G3	SAE 24 - 1 7/8" - 12 UN
G4	G 1 1/4"
G5	1 1/4" NPT
G6	SAE 20 - 1 5/8" - 12 UN
G7	G 1"
G8	1" NPT
G9	SAE 16 - 1 5/16" - 12 UN
F1	1 1/2" SAE 3000 psi/M
F2	1 1/2" SAE 3000 psi/UNC

RF2 350

Type	A	C
G1	G 1 1/2"	G 1"
G3	SAE 24 - 1 7/8" - 12 UN	SAE 16 - 1 5/16" - 12 UN

4 - By-pass valve

<input type="text" value="B"/>	1.75 bar
<input type="text" value="E"/>	3 bar

5 - Filter element

<input type="text" value="A03"/>	Inorganic microfibre 3 μ	} Absolute filtration βx(c) ≥ 1000
<input type="text" value="A06"/>	Inorganic microfibre 6 μ	
<input type="text" value="A10"/>	Inorganic microfibre 10 μ	
<input type="text" value="A16"/>	Inorganic microfibre 16 μ	
<input type="text" value="A25"/>	Inorganic microfibre 25 μ	
<input type="text" value="M25"/>	Wire mesh	} Nominal Filtration
<input type="text" value="P10"/>	Resin impregnated paper	} Nominal Filtration
<input type="text" value="P25"/>	Resin impregnated paper	

6 - Filter element seals

<input type="text" value="N"/>	NBR
<input type="text" value="V"/>	FPM
<input type="text" value="W*"/>	NBR (only for filter element type Axx and Mxx)
<input type="text" value="Z*"/>	FPM (only for filter element type Axx and Mxx)

7 - Option

<input type="text" value="P01"/>	MP Filtri standard
----------------------------------	--------------------

* Compatible with fluid HFA, HFB, HFC

MP Filtri - The filter functions as described in this bulletin are valid exclusively for original MP Filtri filter elements and replacement parts. All rights reserved

The data in this publication are purely guideline. MP Filtri reserves the right to make changes to the models described herein at any time it deems fit in relation to technical or commercial requirements. The colours of the products shown on the cover are purely guideline. Copyright. All rights reserved.

SERIES

CLOGGING INDICATORS



Production summary



Contamination monitoring products

- Calibrated on test rigs manufactured and certified to ISO 11943 based on methods from ISO 11171
- On-line and In-line counting to 400 bar
- Bottle sampler options
- Mobile designs RS 232 - RS 485 digital bus interface



Suction filters

- Flow rates to 620 l/min

Mounting:

- Tank immersed
- In-Line
- In tank with shut off valve
- In tank with flooded suction



Return filters

- Flow rates to 3000 l/min

- Pressure to 20 bar

Mounting:

- In-Line
- Tank top
- In single and duplex designs



Pressure filters

- Flow rates to 700 l/min

- Pressure from 110 bar to 560 bar

Mounting:

- In-Line
- Manifold
- In single and duplex designs



Spin-On filters

- Flow rates to 300 l/min

- Pressure to 35 bar

Mounting:

- In-Line
- Tank top

Production summary



Stainless Steel Pressure filters

- Flow rates to 100 l/min
- Pressure from 350 bar to 700 bar

Mounting:

- In-Line
- Manifold
- In single and duplex designs



In-Line filters

- Flow rates to 3000 l/min
- Pressure to 80 bar

Mounting:

- In-Line
- Parallel manifold version
- In single and duplex designs



Filtration units

- Flow rates from 15 l/min to 200 l/min
- In static and mobile style



Accessories

- Oil filler and air breather plugs
- Optical and electrical level gauges
- Pressure gauge valve selectors
- Pipe fixing brackets
- Pressure gauges



Mechanical Products

- Aluminium bell housings for motors from 0.12 kW to 400 kW
- Couplings in Aluminium - Cast Iron - Steel
- Damping rings
- Support feet
- Aluminium tanks
- Inspection doors

Introduction

Filter elements are efficient only if their Dirt Holding Capacity is fully exploited. This is achieved by using filter housings equipped with clogging indicators.

These devices trip when the clogging of the filter element causes an increasing in pressure drop across the filter element.

The indicator is set to alarm before the element becomes fully clogged.

MP Filtri can supply indicators of the following designs:

- Vacuum switches and gauges
- Pressure switches and gauges
- Differential pressure indicators

These type of devices can be provided with a visual, electrical or both signals.

The electronic model (only available for differential type indicators) with warning signals (75% of clogging) and alarm (clogging).

Index

	PAGE
Suitable indicator types	5
Quick reference guide	6 - 7
Vacuum indicators	8
Barometric indicators	12
Differential indicators	16
Stainless Steel differential indicators	22
Comparative table Old - New code	26

VACUUM INDICATORS

Vacuum indicators are used on the Suction line to check the efficiency of the filter element. They measure the pressure downstream of the filter element. Standard items are produced with R 1/4" EN 10226 connection. Available products with R 1/8" EN 10226 to be fitted on MPS series.

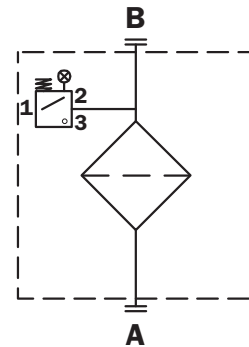
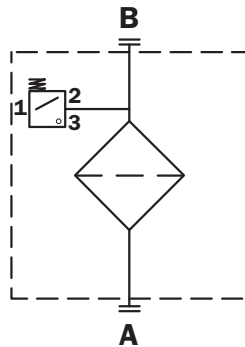
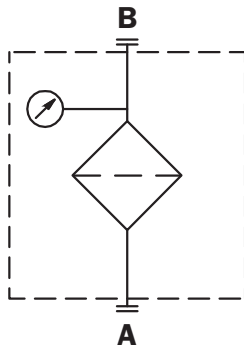

BAROMETRIC INDICATORS

Pressure indicators are used on the Return line to check the efficiency of the filter element. They measure the pressure upstream of the filter element. Standard items are produced with R 1/8" EN 10226 connection.

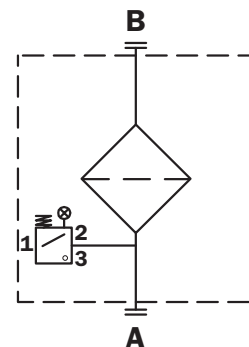
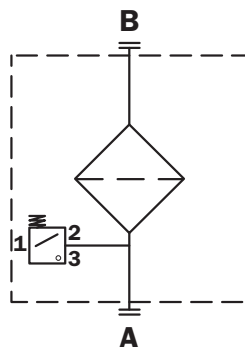
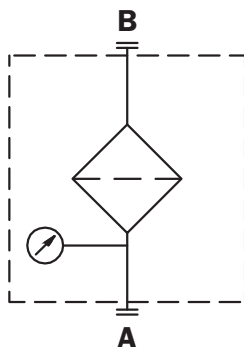

DIFFERENTIAL INDICATORS

Differential indicators are used on the Pressure line to check the efficiency of the filter element. They measure the pressure upstream and downstream of the filter element (differential pressure). Standard items are produced with special connection G 1/2" size. Also available in Stainless Steel models.

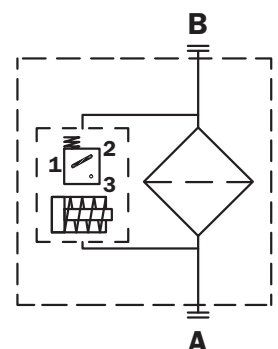
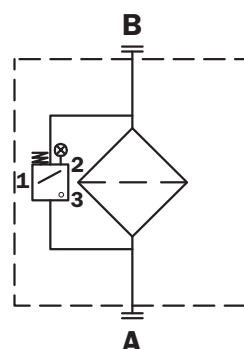
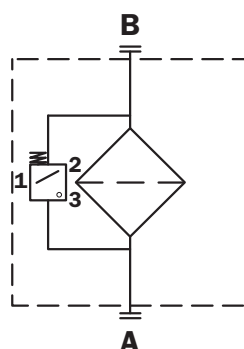
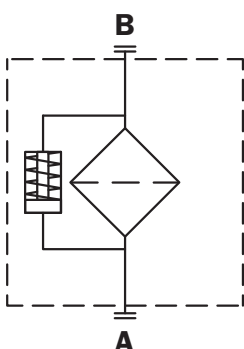

Quick reference guide

Filter series	VISUAL INDICATOR	ELECTRICAL INDICATOR	ELECTRICAL/VISUAL INDICATOR	ELECTRONIC INDICATOR
Suction filters				
SF2 250 - 251 - 350 SF2 500 - 501 - 502 - 503 - 504 - 505 SF2 510 - 535 - 540 FAS	VVA16P01 VVR16P01	VEA21AA50P01	VLA21AA51P01 VLA21AA52P01 VLA21AA53P01 VLA21AA71P01	
Return filters				
MPF - MPT with bypass 1,75 bar MPH with bypass 1,75 bar	BVA14P01 BVR14P01 BVP15HAP01 BVP15HMP01	BEA15HA50P01 BEM15HA41P01	BLA15HA51P01 BLA15HA52P01 BLA15HA53P01 BLA15HA71P01	
MPF - MPT with bypass 3 bar MPH with bypass 2,5 bar FRI 255 RF2 250	BVA25P01 BVR25P01 BVP20HAP01 BVP20HMP01	BEA20HA50P01 BEM20HA41P01	BLA20HA51P01 BLA20HA52P01 BLA20HA53P01 BLA20HA71P01	
FRI 025 - 040 - 100 - 250 - 630 - 850	DVA20xP01 DVM20xP01	DEA20xA50P01 DEM20xAxxP01	DLA20xA51P01 DLA20xA52P01 DLA20xA71P01 DLE20xA50P01 DLE20xF50P01	DTA20xF70P01
Suction/Return filters				
MRS 116 - 165 - 166 Suction line	VVB16P01 VVS16P01	VEB21AA50P01	VLB21AA51P01 VLB21AA52P01 VLB21AA53P01 VLB21AA71P01	
MRS 116 - 165 - 166 Return line	BVA14P01 BVR14P01 BVP15HAP01 BVP15HMP01	BEA15HA50P01 BEM15HA41P01	BLA15HA51P01 BLA15HA52P01 BLA15HA53P01 BLA15HA71P01	
Spin-On filters				
MPS 050 - 070 - 100 - 150 MPS 200 - 250 - 300 - 350 Suction line	VVB16P01 VVS16P01	VEB21AA50P01	VLB21AA51P01 VLB21AA52P01 VLB21AA53P01 VLB21AA71P01	
MPS 050 - 070 - 100 - 150 MPS 200 - 250 - 300 - 350 MST 050 - 070 - 100 - 150 Return line	BVA14P01 BVR14P01 BVP15HAP01 BVP15HMP01	BEA15HA50P01 BEM15HA41P01	BLA15HA51P01 BLA15HA52P01 BLA15HA53P01 BLA15HA71P01	
MPS 051 - 071 - 101 - 151 MPS 301 - 351 MSH 050 - 070 - 100 - 150 In-line	DVA12xP01 DVM12xP01	DEA12xA50P01 DEM12xAxxP01	DLA12xA51P01 DLA12xA52P01 DLA12xA71P01 DLE12xA50P01 DLE12xF50P01	

Quick reference guide

Filter series	VISUAL INDICATOR	ELECTRICAL INDICATOR	ELECTRICAL/VISUAL INDICATOR	ELECTRONIC INDICATOR
Low Pressure In-Line filters				
LMP 110 - 112 - 116 - 118 - 119 LMP 120 - 122 - 123 LMP 210 - 211 LMP 400 - 401 - 430 - 431 LMP 900 - 901 - 950 - 951 LMD 400 - 401 - 431 - 951 With bypass valve	DVA20xP01 DVM20xP01	DEA20xA50P01 DEM20xAxxP01	DLA20xA51P01 DLA20xA52P01 DLA20xA71P01 DLE20xA50P01 DLE20xF50P01	DTA20xF70P01
LMP 110 - 112 - 116 - 118 - 119 LMP 120 - 122 - 123 LMP 210 - 211 LMP 400 - 401 - 430 - 431 LMP 900 - 901 - 950 - 951 LMD 400 - 401 - 431 - 951 MPD 250 - 251 Without bypass valve	DVA50xP01 DVM50xP01	DEA50xA50P01 DEM50xAxxP01	DLA50xA51P01 DLA50xA52P01 DLA50xA71P01 DLE50xA50P01 DLE50xF50P01	DTA50xF70P01
High Pressure In-Line filters				
FMP 039 - 065 - 135 - 320 FMM 050 FHP 010 - 011 - 065 - 135 - 320 - 500 FHB 050 - 135 - 320 FHM 006 - 007 - 010 - 050 - 135 - 320 - 500 FHF 325 FHD 021 - 051 - 326 - 333 With bypass valve	DVA50xP01 DVM50xP01	DEA50xA50P01 DEM50xAxxP01	DLA50xA51P01 DLA50xA52P01 DLA50xA71P01 DLE50xA50P01 DLE50xF50P01	DTA50xF70P01
FMP 039 - 065 - 135 - 320 FMM 050 FHP 010 - 011 - 065 - 135 - 320 - 500 FHB 050 - 135 - 320 FHM 006 - 007 - 010 - 050 - 135 - 320 - 500 FHF 325 FHD 021 - 051 - 326 - 333 Without bypass valve	DVA70xP01 DVM70xP01	DEA70xA50P01 DEM70xAxxP01	DLA70xA51P01 DLA70xA52P01 DLA70xA71P01 DLE70xA50P01 DLE70xF50P01	DTA70xF70P01
Stainless Steel High Pressure In-Line filters				
FZB 039 FZP 039 - 136 FZH 010 - 011 - 039 With bypass valve	DVX50xP01 DVY50xP01	DEX50xA50P01	DLX50xA51P01 DLX50xA52P01 DLY50xA50P01	
FZB 039 FZP 039 - 136 FZH 010 - 011 - 039 Without bypass valve	DVX70xP01 DVY70xP01	DEX70xA50P01	DLX70xA51P01 DLX70xA52P01 DLY70xA50P01	

VACUUM INDICATORS

VEA - VEB

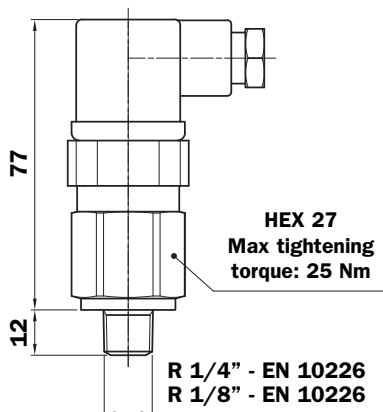

Available connections:
R 1/4" EN 10226 (VEA21AA50P01)
R 1/8" EN 10226 (VEB21AA50P01)

Electrical Vacuum Indicator

Materials:

- Body: Brass
- Internal parts: Brass - Nylon
- Seals: NBR

Technical data:

- Indicator type: Electrical vacuum indicator
- Setting pressure: -0,21 bar \pm 10%
- Max working pressure: 10 bar
- Proof pressure: 15 bar
- Working temperature: From -25 °C to +80 °C
- Compatibility with fluids: Mineral oils, Synthetic fluids
HFA, HFB, HFC fluids in according to ISO 2943

Electrical data:

- Resistive load: 5 A / 14 Vdc
4 A / 30 Vdc
5 A / 125 VAC
5 A / 250 VAC
- Electrical connections: 50 - EN 175301-803
- Protection degree: IP 65 in according to EN 60529
- Available ATEX product: II 1GD Ex ia IIC Tx Ex ia IIC Tx °C X

HYDRAULIC SYMBOL

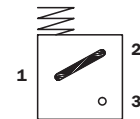

ELECTRICAL SYMBOL

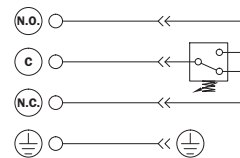

VLA - VLB

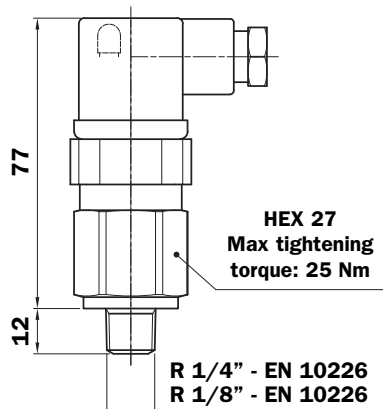

Available connections:
R 1/4" EN 10226 (VLA21AAxxP01)
R 1/8" EN 10226 (VLB21AAxxP01)

Electrical/Visual Vacuum Indicator

Materials:

- Body: Brass
- Internal parts: Brass - Nylon
- Seals: NBR

Technical data:

- Indicator type: Electrical/Visual vacuum indicator
- Setting pressure: -0,21 bar \pm 10%
- Max working pressure: 10 bar
- Proof pressure: 15 bar
- Working temperature: From -25 °C to +80 °C
- Compatibility with fluids: Mineral oils, Synthetic fluids
HFA, HFB, HFC fluids in according to ISO 2943

Electrical data:

- Resistive load: 51: 0,8 A / 24 Vdc
52: 0,2 A / 115 Vdc
53: 4 A / 230 Vdc
- Electrical connections: 51 - EN 175301-803 (24 Vdc lamps)
52 - EN 175301-803 (110 Vdc lamps)
53 - EN 175301-803 (230 VAC lamps)
- Protection degree: IP 65 in according to EN 60529

HYDRAULIC SYMBOL

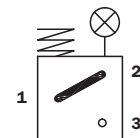

ELECTRICAL SYMBOL

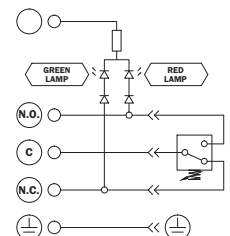

VLA - VLB

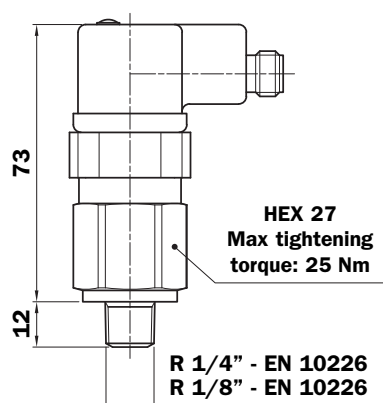

Available connections:
R 1/4" EN 10226 (VLA21AA71P01)
R 1/8" EN 10226 (VLB21AA71P01)

Electrical/Visual Vacuum Indicator

Materials:

- Body: Brass
- Internal parts: Brass - Nylon
- Seals: NBR

Technical data:

- Indicator type: Electrical/Visual vacuum indicator
- Setting pressure: -0,21 bar \pm 10%
- Max working pressure: 10 bar
- Proof pressure: 15 bar
- Working temperature: From -25 °C to +80 °C
- Compatibility with fluids: Mineral oils, Synthetic fluids
HFA, HFB, HFC fluids in according to ISO 2943

Electrical data:

- Resistive load: 0,4 A / 24 Vdc
- Electrical connections: 71 - M12 IEC 61076-2-101 (24 Vdc lamps)
- Protection degree: IP 65 in according to EN 60529

HYDRAULIC SYMBOL

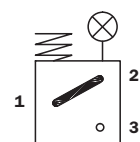

ELECTRICAL SYMBOL

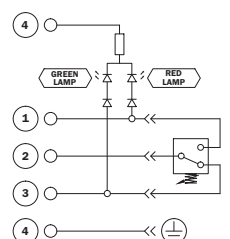

VACUUM INDICATORS

VVA - VVB

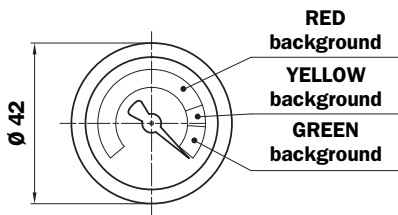

R 1/4" - EN 10226
R 1/8" - EN 10226

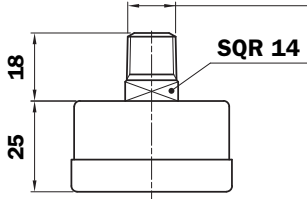

Available connections:
R 1/4" EN 10226 (VVA16P01)
R 1/8" EN 10226 (VVB16P01)

Axial Vacuum Gauge

Materials:

- Case: Painted Steel
- Window: Clear plastic
- Dial: Painted Steel
- Pointer: Painted Aluminium
- Pressure connection: Brass
- Pressure element: Bourdon tub Cu-alloy soft soldered

Technical data:

- Indicator type: Axial vacuum gauge
- Max working pressure: Static: 7 bar
Fluctuating: 6 bar
Short time: 10 bar
- Working temperature: From -40 °C to +60 °C
- Compatibility with fluids: Mineral oils, Synthetic fluids
HFA, HFB, HFC fluids in according to ISO 2943
- Accuracy class: cl. 2.5
- Protection degree: IP 31 in according to EN 60529

HYDRAULIC SYMBOL



GRADUATED DISPLAY

GREEN BACKGROUND
(from 0 to -12 cmHg)
Clean filter element

YELLOW BACKGROUND
(from -12 to -18 cmHg)
Warning

GREEN BACKGROUND
(from -18 to -76 cmHg)
Bypass

VVR - VVS

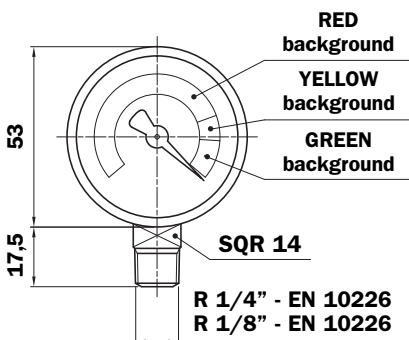

R 1/4" - EN 10226
R 1/8" - EN 10226

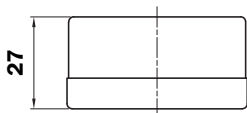

Available connections:
R 1/4" EN 10226 (VVR16P01)
R 1/8" EN 10226 (VVS16P01)

Radial Vacuum Gauge

Materials:

- Case: Painted Steel
- Window: Clear plastic
- Dial: Painted Steel
- Pointer: Painted Aluminium
- Pressure connection: Brass
- Pressure element: Bourdon tub Cu-alloy soft soldered

Technical data:

- Indicator type: Radial vacuum gauge
- Max working pressure: Static: 7 bar
Fluctuating: 6 bar
Short time: 10 bar
- Working temperature: From -40 °C to +60 °C
- Compatibility with fluids: Mineral oils, Synthetic fluids
HFA, HFB, HFC fluids in according to ISO 2943
- Accuracy class: cl. 2.5
- Protection degree: IP 31 in according to EN 60529

HYDRAULIC SYMBOL



GRADUATED DISPLAY

GREEN BACKGROUND
(from 0 to -12 cmHg)
Clean filter element

YELLOW BACKGROUND
(from -12 to -18 cmHg)
Warning

GREEN BACKGROUND
(from -18 to -76 cmHg)
Bypass

Ordering information VE - VL - VV

Series	1	2	3	4	5	6	7
VE	<input type="checkbox"/>	<input type="checkbox"/>	<input type="checkbox"/>	<input type="checkbox"/>	<input type="checkbox"/>	<input type="checkbox"/>	<input type="checkbox"/>
Example:	VE	A	21	A	A	50	P01

Series	1	2	3	4	5	6	7
VL	<input type="checkbox"/>	<input type="checkbox"/>	<input type="checkbox"/>	<input type="checkbox"/>	<input type="checkbox"/>	<input type="checkbox"/>	<input type="checkbox"/>
Example:	VL	A	21	A	A	52	P01

Series	1	2	3	7
VV	<input type="checkbox"/>	<input type="checkbox"/>	<input type="checkbox"/>	<input type="checkbox"/>
Example:	VV	A	16	P01

1 - Series

<input type="checkbox"/> VE	Electrical indicator
<input type="checkbox"/> VL	Electrical/Visual indicator
<input type="checkbox"/> VV	Visual indicator

2 - Type

VE - VL series

<input type="checkbox"/> A	R 1/4" EN 10226 connection
<input type="checkbox"/> B	R 1/8" EN 10226 connection

VV series

<input type="checkbox"/> A	Axial vacuumeter R 1/4" EN 10226 connection
<input type="checkbox"/> B	Axial vacuumeter R 1/8" EN 10226 connection
<input type="checkbox"/> R	Radial vacuumeter R 1/4" EN 10226 connection
<input type="checkbox"/> S	Radial vacuumeter R 1/8" EN 10226 connection

3 - Setting pressure

VEA - VLA series

<input type="checkbox"/> 21	-0,21 bar
------------------------------------	-----------

VVA - VVR series

<input type="checkbox"/> 16	-0,16 bar
------------------------------------	-----------

4 - Seals (excluded for VV)

<input type="checkbox"/> A	NBR
<input type="checkbox"/>	On request

5 - Thermostat (excluded for VV)

<input type="checkbox"/> A	Without thermostat
-----------------------------------	--------------------

6 - Electrical connection (excluded for VV)

VEA series

<input type="checkbox"/> 50	EN 175301-803 connector
------------------------------------	-------------------------

VLA series

<input type="checkbox"/> 51	EN 175301-803 clear connector with 24 V lamps
<input type="checkbox"/> 52	EN 175301-803 clear connector with 110 V lamps
<input type="checkbox"/> 53	EN 175301-803 clear connector with 230 V lamps
<input type="checkbox"/> 71	M12 IEC 61076-2-101 clear connector with 24 V lamps

7 - Option

<input type="checkbox"/> P01	MP Filtri standard
<input type="checkbox"/> Pxx	Customer request

MP Filtri - The filter functions as described in this bulletin are valid exclusively for original MP Filtri filter elements and replacement parts. All rights reserved

The data in this publication are purely guideline. MP Filtri reserves the right to make changes to the models described herein at any time it deems fit in relation to technical or commercial requirements. The colours of the products shown on the cover are purely guideline. Copyright. All rights reserved.

BAROMETRIC INDICATORS

BEA

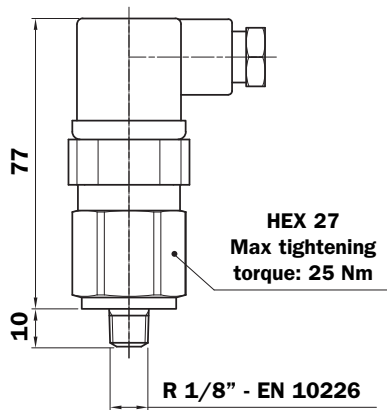

Available setting:
1,5 bar $\pm 10\%$ (BEA15HA50P01)
2 bar $\pm 10\%$ (BEA20HA50P01)

Electrical Pressure Indicator

Materials:

- Body: Brass
- Internal parts: Brass - Nylon
- Seals: NBR

Technical data:

- Indicator type: Electrical pressure indicator
- Max working pressure: 40 bar
- Proof pressure: 60 bar
- Working temperature: From -25°C to $+80^{\circ}\text{C}$
- Compatibility with fluids: Mineral oils, Synthetic fluids
HFA, HFB, HFC fluids in according to ISO 2943

Electrical data:

- Resistive load: 5 A / 14 VDC
4 A / 30 VDC
5 A / 125 VAC
5 A / 250 VAC
- Electrical connections: 50 - EN 175301-803
- Protection degree: IP 65 in according to EN 60529
- Available Atex product II 1GD Ex ia IIC Tx Ex ia IIC Tx $^{\circ}\text{C}$ X

HYDRAULIC SYMBOL

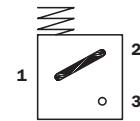

ELECTRICAL SYMBOL

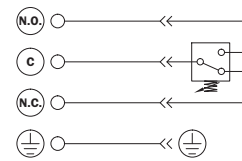

BEM

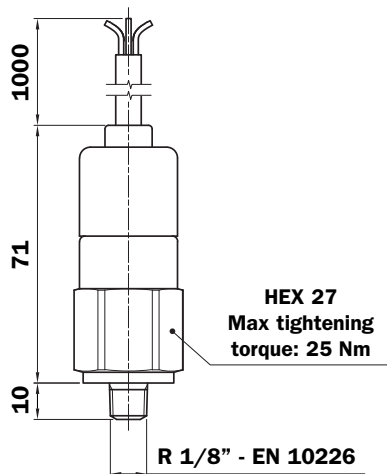

Available setting:
1,5 bar $\pm 10\%$ (BEM15HA50P01)
2 bar $\pm 10\%$ (BEM20HA50P01)

Electrical Pressure Indicator

Materials:

- Body: Brass
- Internal parts: Brass - Nylon
- Seals: HNBR

Technical data:

- Indicator type: Electrical pressure indicator
- Max working pressure: 40 bar
- Proof pressure: 60 bar
- Working temperature: From -25°C to $+80^{\circ}\text{C}$
- Compatibility with fluids: Mineral oils, Synthetic fluids
HFA, HFB, HFC fluids in according to ISO 2943

Electrical data:

- Resistive load: 5 A / 14 VDC
4 A / 30 VDC
5 A / 125 VAC
5 A / 250 VAC
- Electrical connections: 50 - EN 175301-803
- Protection degree: IP 67 in according to EN 60529

On request this indicator can be provided with main connectors in use for wirings.

HYDRAULIC SYMBOL

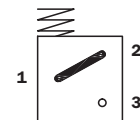

ELECTRICAL SYMBOL

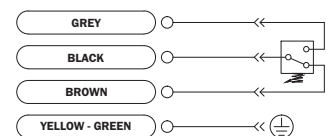

BLA

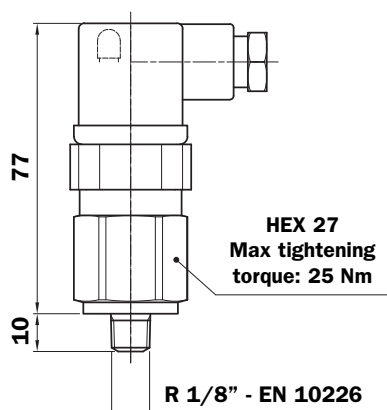

Available setting:
1,5 bar $\pm 10\%$ (BLA15HAxxP01)
2 bar $\pm 10\%$ (BLA20HAxxP01)

Electrical/Visual Pressure Indicator

Materials:

- Body: Brass
- Internal parts: Brass - Nylon
- Seals: NBR

Technical data:

- Indicator type: Electrical/Visual pressure indicator
- Max working pressure: 40 bar
- Proof pressure: 60 bar
- Working temperature: From -25°C to $+80^{\circ}\text{C}$
- Compatibility with fluids: Mineral oils, Synthetic fluids
HFA, HFB, HFC fluids in according to ISO 2943

Electrical data:

- Resistive load: 51: 0,8 A / 24 VDC
52: 0,2 A / 115 VDC
53: 4 A / 230 VDC
- Electrical connections: 51 - EN 175301-803 (24 VDC lamps)
52 - EN 175301-803 (110 VDC lamps)
53 - EN 175301-803 (230 VAC lamps)
- Protection degree: IP 65 in according to EN 60529

HYDRAULIC SYMBOL

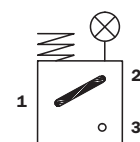

ELECTRICAL SYMBOL

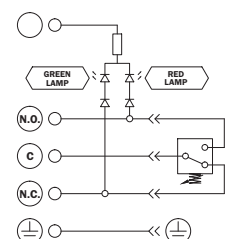

BAROMETRIC INDICATORS

BLA

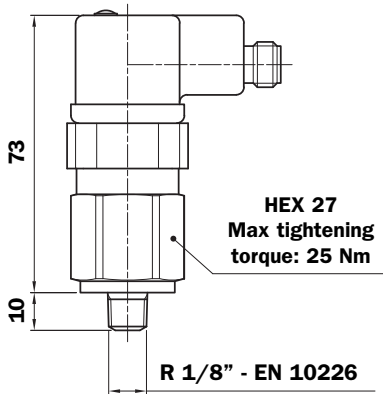

Available setting:
1,5 bar $\pm 10\%$ (BLA15HA71P01)
2 bar $\pm 10\%$ (BLA20HA71P01)

Electrical/Visual Pressure Indicator

Materials:

- Body: Brass
- Internal parts: Brass - Nylon
- Seals: NBR

Technical data:

- Indicator type: Electrical/Visual pressure indicator
- Max working pressure: 40 bar
- Proof pressure: 60 bar
- Working temperature: From -25°C to $+80^{\circ}\text{C}$
- Compatibility with fluids: Mineral oils, Synthetic fluids
HFA, HFB, HFC fluids in according to ISO 2943

Electrical data:

- Resistive load: 0,4 A / 24 VDC
- Electrical connections: 71 - M12 IEC 61076-2-101 (24 VDC lamps)
- Protection degree: IP 65 in according to EN 60529

HYDRAULIC SYMBOL

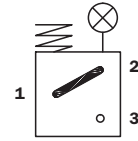

ELECTRICAL SYMBOL

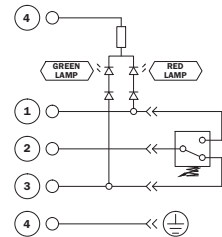

BVA

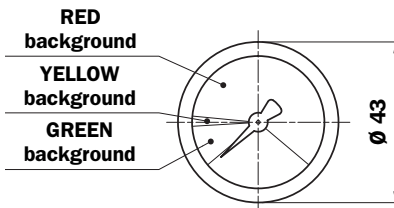

R 1/8" - EN 10226

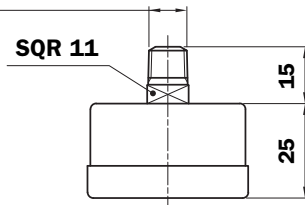

Available setting:
1,4 bar $\pm 10\%$ (BVA14P01)
2,5 bar $\pm 10\%$ (BVA25P01)

Axial Pressure Gauge

Materials:

- Case: Painted Steel
- Window: Clear plastic
- Dial: Painted Steel
- Pointer: Painted Aluminium
- Pressure connection: Brass
- Pressure element: Bourdon tub cu-alloy soft soldered

Technical data:

- Indicator type: Axial pressure gauge
- Max working pressure: Static: 7 bar
Fluctuating: 6 bar
Short time: 10 bar
- Working temperature: From -40°C to $+60^{\circ}\text{C}$
- Compatibility with fluids: Mineral oils, Synthetic fluids
HFA, HFB, HFC fluids in according to ISO 2943
- Accuracy class: cl. 2.5
- Protection degree: IP 31 in according to EN 60529

HYDRAULIC SYMBOL



DYED RANGE

- BVA14P01
GREEN BACKGROUND (from 0 to 1,4 bar)
Clean filter element
YELLOW BACKGROUND (from 1,4 to 1,7 bar)
Warning
RED BACKGROUND (from 1,7 to 10 bar)
Bypass
- BVA25P01
GREEN BACKGROUND (from 0 to 2,5 bar)
Clean filter element
YELLOW BACKGROUND (from 2,5 to 3 bar)
Warning
RED BACKGROUND (from 3 to 10 bar)
Bypass

BVR

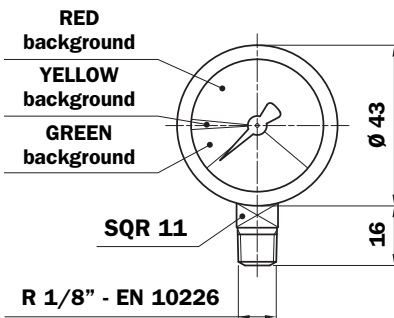

R 1/8" - EN 10226

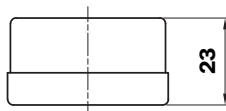

Available setting:
1,4 bar $\pm 10\%$ (BVR14P01)
2,5 bar $\pm 10\%$ (BVR25P01)

Radial Pressure Gauge

Materials:

- Case: Painted Steel
- Window: Clear plastic
- Dial: Painted Steel
- Pointer: Painted Aluminium
- Pressure connection: Brass
- Pressure element: Bourdon tub cu-alloy soft soldered

Technical data:

- Indicator type: Radial pressure gauge
- Max working pressure: Static: 7 bar
Fluctuating: 6 bar
Short time: 10 bar
- Working temperature: From -40°C to $+60^{\circ}\text{C}$
- Compatibility with fluids: Mineral oils, Synthetic fluids
HFA, HFB, HFC fluids in according to ISO 2943
- Accuracy class: cl. 2.5
- Protection degree: IP 31 in according to EN 60529

HYDRAULIC SYMBOL



DYED RANGE

- BVR14P01
GREEN BACKGROUND (from 0 to 1,4 bar)
Clean filter element
YELLOW BACKGROUND (from 1,4 to 1,7 bar)
Warning
RED BACKGROUND (from 1,7 to 10 bar)
Bypass
- BVR25P01
GREEN BACKGROUND (from 0 to 2,5 bar)
Clean filter element
YELLOW BACKGROUND (from 2,5 to 3 bar)
Warning
RED BACKGROUND (from 3 to 10 bar)
Bypass

BAROMETRIC INDICATORS

BVP - BVQ

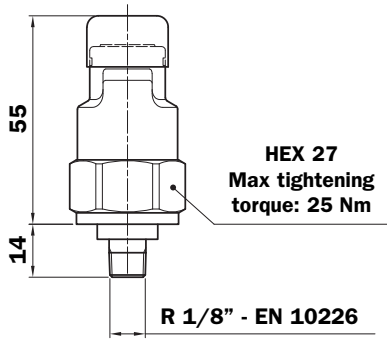

Available setting:
 1,5 bar $\pm 10\%$ (BVP15AP01 - BVQ15AP01)
 2 bar $\pm 10\%$ (BVP20AP01 - BVQ20AP01)

Visual Pressure Indicator

Materials:

- Body: Brass
- Internal parts: Nylon
- Seals: NBR

Technical data:

- Indicator type: Visual pressure indicator
- Reset: BVP - Automatic reset
BVQ - Manual reset
- Max working pressure: 10 bar
- Proof pressure: 15 bar
- Working temperature: From -25°C to $+80^{\circ}\text{C}$
- Compatibility with fluids: Mineral oils, Synthetic fluids
HFA, HFB, HFC fluids in according to ISO 2943
- Protection degree: IP 45 in according to EN 60529

HYDRAULIC SYMBOL

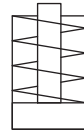

SIGNALS

GREEN BUTTON: INLET PRESSURE

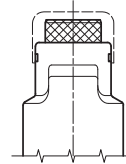

RED BUTTON: CLOGGED FILTER ELEMENT

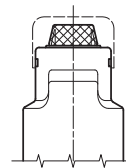

Ordering information BE - BL - BV

Series	1	2	3	4	5	6	7
BE	<input type="checkbox"/>	<input type="checkbox"/>	<input type="checkbox"/>	<input type="checkbox"/>	<input type="checkbox"/>	<input type="checkbox"/>	<input type="checkbox"/>
Example:	BE	A	20	H	A	50	P01

Series	1	2	3	4	5	6	7
BL	<input type="checkbox"/>	<input type="checkbox"/>	<input type="checkbox"/>	<input type="checkbox"/>	<input type="checkbox"/>	<input type="checkbox"/>	<input type="checkbox"/>
Example:	BL	A	20	H	A	52	P01

Series	1	2	3	4	7
BV	<input type="checkbox"/>	<input type="checkbox"/>	<input type="checkbox"/>	<input type="checkbox"/>	<input type="checkbox"/>
Example:	BV	P	20	H	P01

Series	1	2	3	7
BV	<input type="checkbox"/>	<input type="checkbox"/>	<input type="checkbox"/>	<input type="checkbox"/>
Example:	BV	A	14	P01

1 - Series

<input type="checkbox"/> BE	Electrical indicator
<input type="checkbox"/> BL	Electrical/Visual indicator
<input type="checkbox"/> BV	Visual indicator

2 - Type

BE series

<input type="checkbox"/> A	Standard type
<input type="checkbox"/> M	With wired connector

BL series

<input type="checkbox"/> A	Standard type
-----------------------------------	---------------

BV series

<input type="checkbox"/> A	Axial manometer
<input type="checkbox"/> R	Radial manometer
<input type="checkbox"/> P	Visual pressure indicator - Automatic reset
<input type="checkbox"/> Q	Visual pressure indicator - Manual reset

3 - Setting pressure

BEA - BEM - BLA - BVP series

<input type="checkbox"/> 15	1,5 bar
<input type="checkbox"/> 20	2 bar

BVA - BVR series

<input type="checkbox"/> 14	1,4 bar
<input type="checkbox"/> 25	2,5 bar

4 - Seals (excluded for BVA - BVR)

<input type="checkbox"/> H	HNBR
<input type="checkbox"/>	On request

5 - Thermostat (excluded for BV)

<input type="checkbox"/> A	Without thermostat
-----------------------------------	--------------------

6 - Electrical connection (excluded for BV)

BEA series

<input type="checkbox"/> 50	EN 175301-803 connector
------------------------------------	-------------------------

BEM series

<input type="checkbox"/> 41	Four core cable
<input type="checkbox"/>	On request

BLA series

<input type="checkbox"/> 51	EN 175301-803 clear connector with 24 V lamps
<input type="checkbox"/> 52	EN 175301-803 clear connector with 110 V lamps
<input type="checkbox"/> 53	EN 175301-803 clear connector with 230 V lamps
<input type="checkbox"/> 71	M12 IEC 61076-2-101 clear connector with 24 V lamps

7 - Option

<input type="checkbox"/> P01	MP Filtri standard
<input type="checkbox"/> Pxx	Customer request

MP Filtri - The filter functions as described in this bulletin are valid exclusively for original MP Filtri filter elements and replacement parts. All rights reserved

The data in this publication are purely guideline. MP Filtri reserves the right to make changes to the models described herein at any time it deems fit in relation to technical or commercial requirements. The colours of the products shown on the cover are purely guideline. Copyright. All rights reserved.

DIFFERENTIAL INDICATORS

DEA

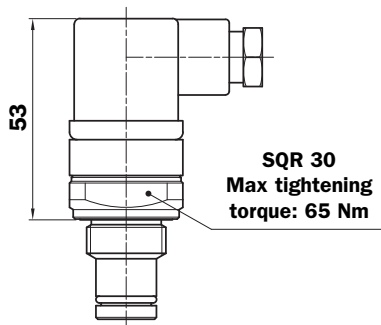

Available setting:

- 1,2 bar ±10% (DEA12xA50P01)
- 2 bar ±10% (DEA20xA50P01)
- 5 bar ±10% (DEA50xA50P01)
- 7 bar ±10% (DEA70xA50P01)
- 9,5 bar ±10% (DEA95xA50P01)

Electrical Differential Indicator

Materials:

- Body: Brass
- Internal parts: Brass - Nylon
- Seals: HNBR - FPM

Technical data:

- Indicator type: Electrical differential indicator
- Max working pressure: 420 bar
- Proof pressure: 630 bar
- Burst pressure: 1260 bar
- Working temperature: From -25 °C to +110 °C
- Compatibility with fluids: Mineral oils, Synthetic fluids
HFA, HFB, HFC fluids in according to ISO 2943

Electrical data:

- Resistive load: 0,2 A / 115 VDC
- Electrical connections: 50 - EN 175301-803
- Protection degree: IP 66 in according to EN 60529
IP 69K in according to ISO 20653

HYDRAULIC SYMBOL

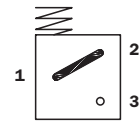

ELECTRICAL SYMBOL

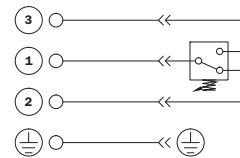

DEM

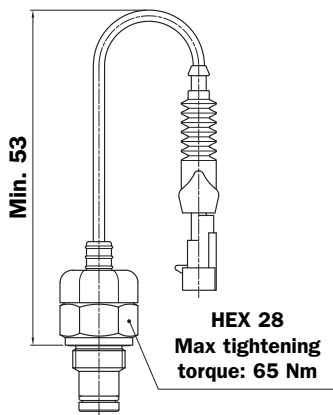

Available setting:

- 1,2 bar ±10% (DEM12xx10P01)
- 2 bar ±10% (DEM20xx10P01)
- 5 bar ±10% (DEM50xx10P01)
- 7 bar ±10% (DEM70xx10P01)
- 9,5 bar ±10% (DEM95xx10P01)

Electrical Differential Indicator

Materials:

- Body: Brass
- Internal parts: Brass - Nylon
- Seals: HNBR - FPM

Technical data:

- Indicator type: Electrical differential indicator
- Max working pressure: 420 bar
- Proof pressure: 630 bar
- Burst pressure: 1260 bar
- Working temperature: From -25 °C to +110 °C
- Compatibility with fluids: Mineral oils, Synthetic fluids
HFA, HFB, HFC fluids in according to ISO 2943

Electrical data:

- Resistive load: 0,2 A / 115 VDC
- Electrical connections: 10 - AMP Superseal series 1,5
- Switching type: Normally open contacts (N.C. on request)
- Thermal lockout: Normally open up to 30 °C (F option)
- Protection degree: IP 66 in according to EN 60529

HYDRAULIC SYMBOL

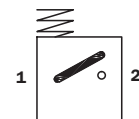

ELECTRICAL SYMBOL

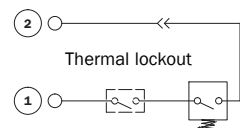

DEM

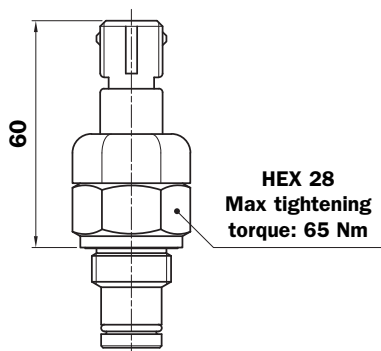

Available setting:

- 1,2 bar ±10% (DEM12xx20P01)
- 2 bar ±10% (DEM20xx20P01)
- 5 bar ±10% (DEM50xx20P01)
- 7 bar ±10% (DEM70xx20P01)
- 9,5 bar ±10% (DEM95xx20P01)

Electrical Differential Indicator

Materials:

- Body: Brass
- Internal parts: Brass - Nylon
- Seals: HNBR - FPM

Technical data:

- Indicator type: Electrical differential indicator
- Max working pressure: 420 bar
- Proof pressure: 630 bar
- Burst pressure: 1260 bar
- Working temperature: From -25 °C to +110 °C
- Compatibility with fluids: Mineral oils, Synthetic fluids
HFA, HFB, HFC fluids in according to ISO 2943

Electrical data:

- Resistive load: 0,2 A / 115 VDC
- Electrical connections: 20 - AMP Time junior
- Switching type: Normally open contacts (N.C. on request)
- Thermal lockout: Normally open up to 30 °C (F option)
- Protection degree: IP 66 in according to EN 60529

HYDRAULIC SYMBOL

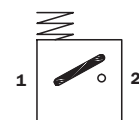

ELECTRICAL SYMBOL

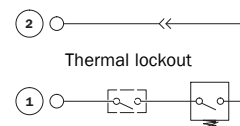

DIFFERENTIAL INDICATORS

DEM

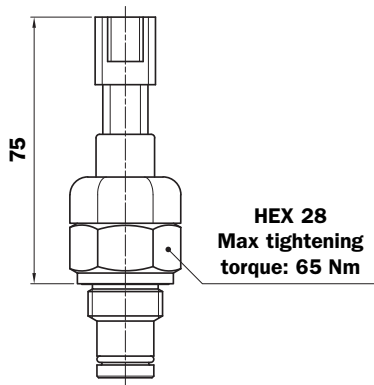

Available setting:
 1,2 bar ±10% (DEM12xx30P01)
 2 bar ±10% (DEM20xx30P01)
 5 bar ±10% (DEM50xx30P01)
 7 bar ±10% (DEM70xx30P01)
 9,5 bar ±10% (DEM95xx30P01)

Electrical Differential Indicator

Materials:

- Body: Brass
- Internal parts: Brass - Nylon
- Seals: HNBR - FPM

Technical data:

- Indicator type: Electrical differential indicator
- Max working pressure: 420 bar
- Proof pressure: 630 bar
- Burst pressure: 1260 bar
- Working temperature: From -25 °C to +110 °C
- Compatibility with fluids: Mineral oils, Synthetic fluids
HFA, HFB, HFC fluids in according to ISO 2943

Electrical data:

- Resistive load: 0,2 A / 115 Vdc
- Electrical connections: 30 - Deutsch DT-04-2-P
- Switching type: Normally open contacts (N.C. on request)
- Thermal lockout: Normally open up to 30 °C (F option)
- Protection degree: IP 66 in according to EN 60529

HYDRAULIC SYMBOL

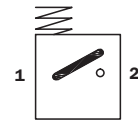

ELECTRICAL SYMBOL

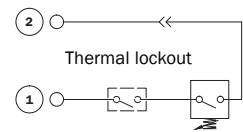

DEM

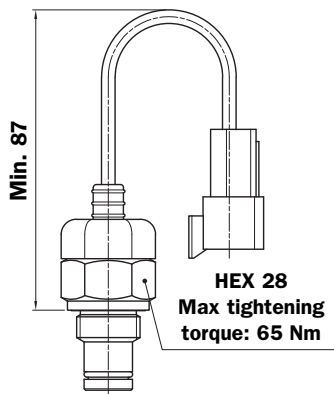

Available setting:
 1,2 bar ±10% (DEM12xx35P01)
 2 bar ±10% (DEM20xx35P01)
 5 bar ±10% (DEM50xx35P01)
 7 bar ±10% (DEM70xx35P01)
 9,5 bar ±10% (DEM95xx35P01)

Electrical Differential Indicator

Materials:

- Body: Brass
- Internal parts: Brass - Nylon
- Seals: HNBR - FPM

Technical data:

- Indicator type: Electrical differential indicator
- Max working pressure: 420 bar
- Proof pressure: 630 bar
- Burst pressure: 1260 bar
- Working temperature: From -25 °C to +110 °C
- Compatibility with fluids: Mineral oils, Synthetic fluids
HFA, HFB, HFC fluids in according to ISO 2943

Electrical data:

- Resistive load: 0,2 A / 115 Vdc
- Electrical connections: 35 - Deutsch DT-04-3-P
- Switching type: SPDT contact
- Thermal lockout: Normally open up to 30 °C (F option)
- Protection degree: IP 66 in according to EN 60529

HYDRAULIC SYMBOL

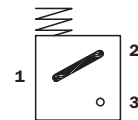

ELECTRICAL SYMBOL

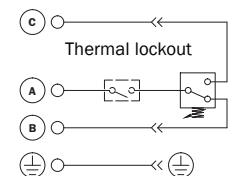

DLA

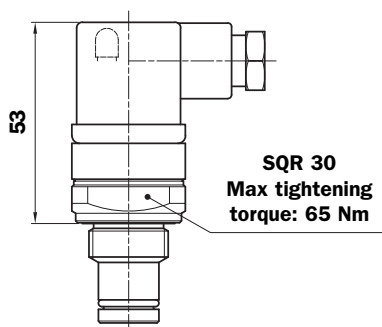

Available setting:
 1,2 bar ±10% (DLA12xAxxP01)
 2 bar ±10% (DLA20xAxxP01)
 5 bar ±10% (DLA50xAxxP01)
 7 bar ±10% (DLA70xAxxP01)
 9,5 bar ±10% (DLA95xAxxP01)

Electrical/Visual Differential Indicator

Materials:

- Body: Brass
- Internal parts: Brass - Nylon
- Seals: HNBR - FPM

Technical data:

- Indicator type: Electrical/Visual differential indicator
- Max working pressure: 420 bar
- Proof pressure: 630 bar
- Burst pressure: 1260 bar
- Working temperature: From -25 °C to +110 °C
- Compatibility with fluids: Mineral oils, Synthetic fluids
HFA, HFB, HFC fluids in according to ISO 2943

Electrical data:

- Resistive load: 51: 0,8 A / 24 Vdc
52: 0,2 A / 115 Vdc
- Electrical connections: 51 - EN 175301-803 (24 Vdc lamps)
52 - EN 175301-803 (110 Vdc lamps)
- Protection degree: IP 66 in according to EN 60529
IP 69K in according to ISO 20653

HYDRAULIC SYMBOL

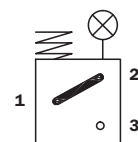

ELECTRICAL SYMBOL

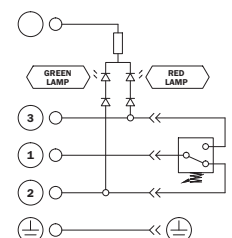

DIFFERENTIAL INDICATORS

DLA

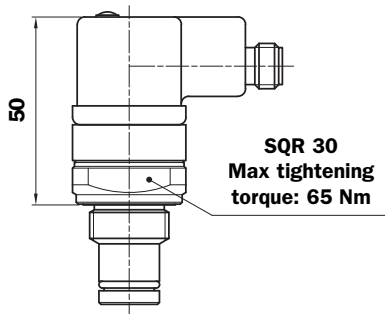

Available setting:

- 1,2 bar ±10% (DLA12xA71P01)
- 2 bar ±10% (DLA20xA71P01)
- 5 bar ±10% (DLA50xA71P01)
- 7 bar ±10% (DLA70xA71P01)
- 9,5 bar ±10% (DLA95xA71P01)

Electrical/Visual Differential Indicator

Materials:

- Body: Brass
- Internal parts: Brass - Nylon
- Seals: HNBR - FPM

Technical data:

- Indicator type: Electrical/Visual differential indicator
- Max working pressure: 420 bar
- Proof pressure: 630 bar
- Burst pressure: 1260 bar
- Working temperature: From -25 °C to +110 °C
- Compatibility with fluids: Mineral oils, Synthetic fluids
HFA, HFB, HFC fluids in according to ISO 2943

Electrical data:

- Resistive load: 0,4 A / 24 Vdc
- Electrical connections: 71 - M12 IEC 61076-2-101 (24 Vdc lamps)
IP 65 in according to EN 60529
- Protection degree: IP 69K in according to ISO 20653

HYDRAULIC SYMBOL

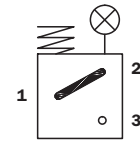

ELECTRICAL SYMBOL

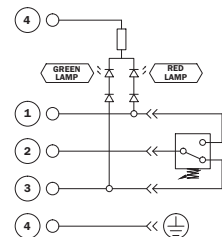

DLE

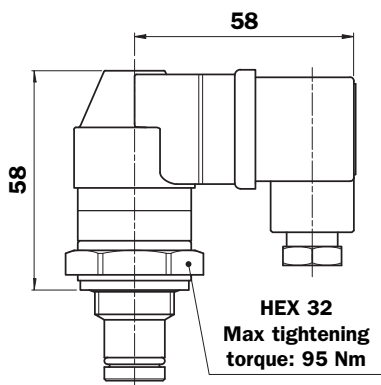

Available setting:

- 1,2 bar ±10% (DLE12VA50P01)
- 2 bar ±10% (DLE20VA50P01)
- 5 bar ±10% (DLE50VA50P01)
- 7 bar ±10% (DLE70VA50P01)
- 9,5 bar ±10% (DLE95VA50P01)

Electrical/Visual Differential Indicator

Materials:

- Body: Brass
- Internal parts: Brass - Nylon
- Seals: FPM

Technical data:

- Indicator type: Electrical/Visual differential indicator
- Max working pressure: 420 bar
- Proof pressure: 630 bar
- Burst pressure: 1260 bar
- Working temperature: From -25 °C to +110 °C
- Compatibility with fluids: Mineral oils, Synthetic fluids
HFA, HFB, HFC fluids in according to ISO 2943

Electrical data:

- Resistive load: 5 A / 250 VAC
- Electrical connections: 50 - EN 175301-803
- Protection degree: IP 65 in according to EN 60529

Available the connector with lamps

HYDRAULIC SYMBOL

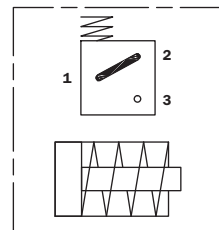

ELECTRICAL SYMBOL

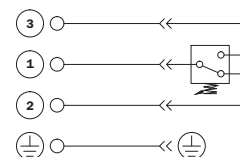

DLE

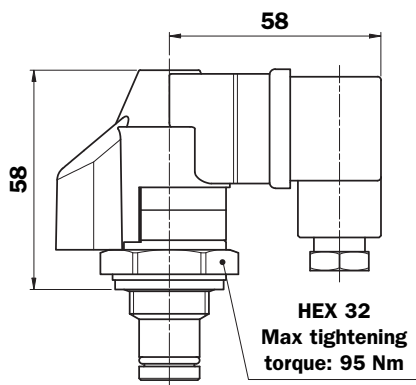

Available setting:

- 1,2 bar ±10% (DLE12VF50P01)
- 2 bar ±10% (DLE20VF50P01)
- 5 bar ±10% (DLE50VF50P01)
- 7 bar ±10% (DLE70VF50P01)
- 9,5 bar ±10% (DLE95VF50P01)

Electrical/Visual Differential Indicator

Materials:

- Body: Brass
- Internal parts: Brass - Nylon
- Seals: FPM

Technical data:

- Indicator type: Electrical/Visual differential indicator
- Max working pressure: 420 bar
- Proof pressure: 630 bar
- Burst pressure: 1260 bar
- Working temperature: From -25 °C to +110 °C
- Compatibility with fluids: Mineral oils, Synthetic fluids
HFA, HFB, HFC fluids in according to ISO 2943

Electrical data:

- Resistive load: 5 A / 250 VAC
- Thermal lockout setting: +30 °C
- Electrical connections: 50 - EN 175301-803
- Protection degree: IP 65 in according to EN 60529

HYDRAULIC SYMBOL

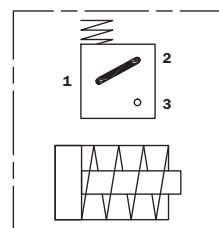

ELECTRICAL SYMBOL

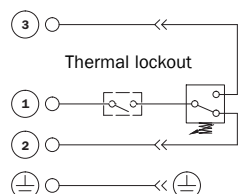

DIFFERENTIAL INDICATORS

DTA

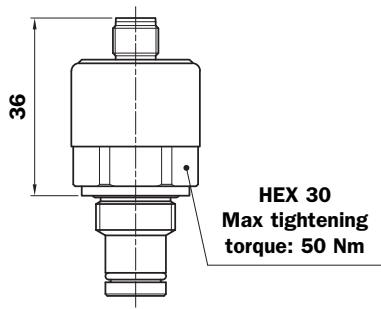

Available setting:
 1,2 bar ±10% (DTA12xF70P01)
 2 bar ±10% (DTA20xF70P01)
 5 bar ±10% (DTA50xF70P01)
 7 bar ±10% (DTA70xF70P01)
 9,5 bar ±10% (DTA95xF70P01)

Electronic Differential Indicator

Materials:

- Body: Brass
- Internal parts: Brass - Nylon
- Seals: NBR

Technical data:

- Indicator type: Electronic differential indicator
- Max working pressure: 420 bar
- Proof pressure: 630 bar
- Burst pressure: 1260 bar
- Working temperature: From -25 °C to +110 °C
- Compatibility with fluids: Mineral oils, Synthetic fluids
HFA, HFB, HFC fluids in according to ISO 2943

Electrical data:

- Power supply: 24 VDC
- Analogue output: From 4 to 20 mA
- Thermal lockout: 30 °C (all output signals stalled up to 30 °C)
- Protection degree: IP 67 in according to EN 60529

HYDRAULIC SYMBOL

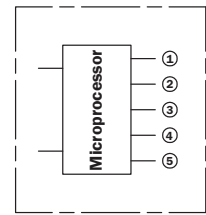

ELECTRICAL SYMBOL

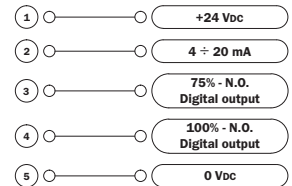

DVA

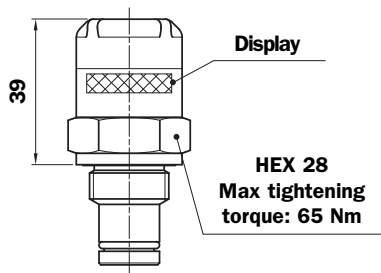

Available setting:
 1,2 bar ±10% (DVA12xP01)
 2 bar ±10% (DVA20xP01)
 5 bar ±10% (DVA50xP01)
 7 bar ±10% (DVA70xP01)
 9,5 bar ±10% (DVA95xP01)

Visual Differential Indicator

Materials:

- Body: Brass
- Internal parts: Brass - Nylon
- Seals: HNBR - FPM

Technical data:

- Indicator type: Visual differential indicator
- Reset: Automatic reset
- Max working pressure: 420 bar
- Proof pressure: 630 bar
- Burst pressure: 1260 bar
- Working temperature: From -25 °C to +110 °C
- Compatibility with fluids: Mineral oils, Synthetic fluids
HFA, HFB, HFC fluids in according to ISO 2943

HYDRAULIC SYMBOL

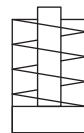

DVM

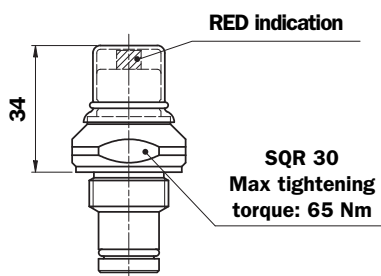

Available setting:
 1,2 bar ±10% (DVM12xP01)
 2 bar ±10% (DVM20xP01)
 5 bar ±10% (DVM50xP01)
 7 bar ±10% (DVM70xP01)
 9,5 bar ±10% (DVM95xP01)

Visual Differential Indicator

Materials:

- Body: Brass
- Internal parts: Brass - Nylon
- Seals: HNBR - FPM

Technical data:

- Indicator type: Visual differential indicator
- Reset: Manual reset
- Max working pressure: 420 bar
- Proof pressure: 630 bar
- Burst pressure: 1260 bar
- Working temperature: From -25 °C to +110 °C
- Compatibility with fluids: Mineral oils, Synthetic fluids
HFA, HFB, HFC fluids in according to ISO 2943

HYDRAULIC SYMBOL



Ordering information DE - DL - DV

Series	1	2	3	4	5	6	7
DE	<input type="text"/>	<input type="text"/>	<input type="text"/>	<input type="text"/>	<input type="text"/>	<input type="text"/>	<input type="text"/>

Example: **DE A 20 H A 50 P01**

Series	1	2	3	4	5	6	7
DL	<input type="text"/>	<input type="text"/>	<input type="text"/>	<input type="text"/>	<input type="text"/>	<input type="text"/>	<input type="text"/>

Example: **DL A 20 H A 52 P01**

Series	1	2	3	4	5	6	7
DT	<input type="text"/>	<input type="text"/>	<input type="text"/>	<input type="text"/>	<input type="text"/>	<input type="text"/>	<input type="text"/>

Example: **DT A 20 H F 70 P01**

Series	1	2	3	4	7
DV	<input type="text"/>	<input type="text"/>	<input type="text"/>	<input type="text"/>	<input type="text"/>

Example: **DV A 20 H P01**

1 - Series

DE	Electrical indicator
DL	Electrical/Visual indicator
DT	Electronic indicator
DV	Visual indicator

2 - Type

DE series

A	Standard type
M	With wired connector

DL series

A	Standard type
E	Standard type for High power supply

DT series

A	Standard type
----------	---------------

DV series

A	Automatic reset
M	Manual reset

3 - Setting pressure

12	1,5 bar
20	2 bar
50	5 bar
70	7 bar
95	9,5 bar

4 - Seals

H	HNBR
<input type="text"/>	On request

5 - Thermostat (excluded for DV)

A	Without thermostat
F	With thermostat (Normally open up to 30°C) Option available only for DEM-DTA series

6 - Electrical connection (excluded for BV)

DEA - DLE series

50	EN 175301-803 connector
-----------	-------------------------

DEM series

10	AMP Superseal series 1,5 (Normally open contacts)
20	AMP Timer Junior (Normally open contacts)
30	Deutsch DT-04-2-P (Normally open contacts)
35	Deutsch DT-04-3-P (Change over contacts)
<input type="text"/>	On request

DLA series

51	EN 175301-803 clear connector with 24 V lamps
52	EN 175301-803 clear connector with 110 V lamps
71	M12 IEC 61076-2-101 clear connector with 24 V lamps

DTA series

70	M12 IEC 61076-2-101 connector
-----------	-------------------------------

7 - Option

P01	MP Filtri standard
Pxx	Customer request

MP Filtri - The filter functions as described in this bulletin are valid exclusively for original MP Filtri filter elements and replacement parts. All rights reserved

The data in this publication are purely guideline. MP Filtri reserves the right to make changes to the models described herein at any time it deems fit in relation to technical or commercial requirements. The colours of the products shown on the cover are purely guideline. Copyright. All rights reserved.

STAINLESS STEEL DIFFERENTIAL INDICATORS

DEX

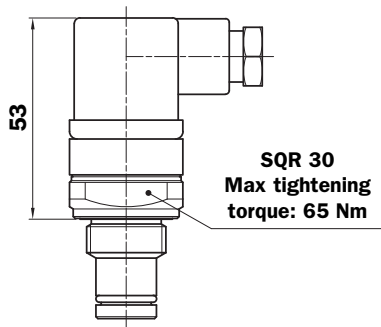

Available setting:
 1,2 bar ±10% (DEX12xA50P01)
 2 bar ±10% (DEX20xA50P01)
 5 bar ±10% (DEX50xA50P01)
 7 bar ±10% (DEX70xA50P01)
 9,5 bar ±10% (DEX95xA50P01)

Electrical Differential Indicator

Materials:

- Body: AISI 316L
- Internal parts: AISI 316L - Nylon
- Seals: HNBR - MFQ

Technical data:

- Indicator type: Electrical differential indicator
- Max working pressure: 420 bar
- Proof pressure: 630 bar
- Burst pressure: 1260 bar
- Working temperature: From -25 °C to +110 °C
- Compatibility with fluids: Mineral oils, Synthetic fluids
HFA, HFB, HFC fluids in according to ISO 2943

Electrical data:

- Resistive load: 0,2 A / 115 VDC
- Electrical connections: 50 - EN 175301-803
- Protection degree: IP 66 in according to EN 60529
IP 69K in according to ISO 20653

HYDRAULIC SYMBOL

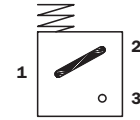

ELECTRICAL SYMBOL

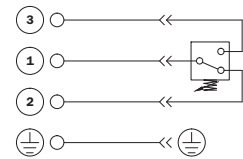

DLX

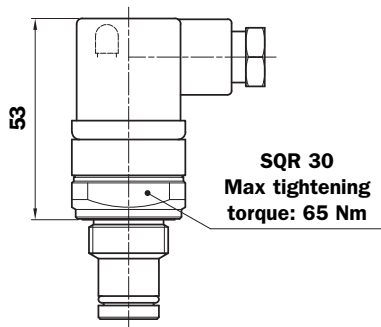

Available setting:
 1,2 bar ±10% (DLX12xAxxP01)
 2 bar ±10% (DLX20xAxxP01)
 5 bar ±10% (DLX50xAxxP01)
 7 bar ±10% (DLX70xAxxP01)
 9,5 bar ±10% (DLX95xAxxP01)

Electrical/Visual Differential Indicator

Materials:

- Body: AISI 316L
- Internal parts: AISI 316L - Nylon
- Seals: HNBR - MFQ

Technical data:

- Indicator type: Electrical differential indicator
- Max working pressure: 420 bar
- Proof pressure: 630 bar
- Burst pressure: 1260 bar
- Working temperature: From -25 °C to +110 °C
- Compatibility with fluids: Mineral oils, Synthetic fluids
HFA, HFB, HFC fluids in according to ISO 2943

Electrical data:

- Resistive load: 51: 0,8 A / 24 VDC
52: 0,2 A / 115 VDC
- Electrical connections: 51 - EN 175301-803 (24 VDC lamps)
52 - EN 175301-803 (110 VDC lamps)
- Protection degree: IP 66 in according to EN 60529
IP 69K in according to ISO 20653

HYDRAULIC SYMBOL

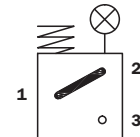

ELECTRICAL SYMBOL

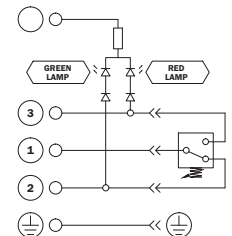

DLY

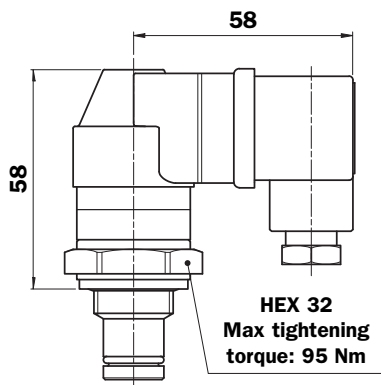

Available setting:
 1,2 bar ±10% (DLY12VA50P01)
 2 bar ±10% (DLY20VA50P01)
 5 bar ±10% (DLY50VA50P01)
 7 bar ±10% (DLY70VA50P01)
 9,5 bar ±10% (DLY95VA50P01)

Electrical/Visual Differential Indicator

Materials:

- Body: AISI 316L
- Internal parts: AISI 316L - Nylon
- Seals: FPM

Technical data:

- Indicator type: Electrical/Visual differential indicator
- Max working pressure: 420 bar
- Proof pressure: 630 bar
- Burst pressure: 1260 bar
- Working temperature: From -25 °C to +110 °C
- Compatibility with fluids: Mineral oils, Synthetic fluids
HFA, HFB, HFC fluids in according to ISO 2943

Electrical data:

- Resistive load: 5 A / 250 VAC
- Electrical connections: 50 - EN 175301-803
- Protection degree: IP 65 in according to EN 60529

HYDRAULIC SYMBOL

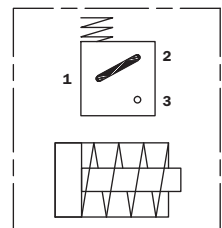

ELECTRICAL SYMBOL

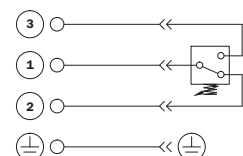

STAINLESS STEEL DIFFERENTIAL INDICATORS

DVX

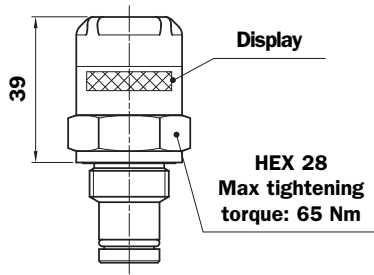

Available setting:
 1,2 bar ±10% (DVX12xP01)
 2 bar ±10% (DVX20xP01)
 5 bar ±10% (DVX50xP01)
 7 bar ±10% (DVX70xP01)
 9,5 bar ±10% (DVX95xP01)

Visual Differential Indicator

Materials:

- Body: AISI 316L
- Internal parts: AISI 316L - Nylon
- Seals: HNBR - MFQ

Technical data:

- Indicator type: Visual differential indicator with automatic reset
- Max working pressure: 420 bar
- Proof pressure: 630 bar
- Burst pressure: 1260 bar
- Working temperature: From -25 °C to +110 °C
- Compatibility with fluids: Mineral oils, Synthetic fluids
HFA, HFB, HFC fluids in according to ISO 2943

HYDRAULIC SYMBOL

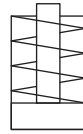

DVY

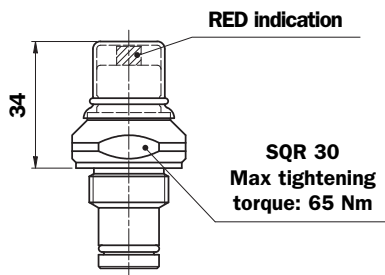

Available setting:
 1,2 bar ±10% (DVY12xP01)
 2 bar ±10% (DVY20xP01)
 5 bar ±10% (DVY50xP01)
 7 bar ±10% (DVY70xP01)
 9,5 bar ±10% (DVY95xP01)

Visual Differential Indicator

Materials:

- Body: AISI 316L
- Internal parts: AISI 316L - Aluminium
- Seals: HNBR - MFQ

Technical data:

- Indicator type: Visual differential indicator
- Max working pressure: 420 bar
- Proof pressure: 630 bar
- Burst pressure: 1260 bar
- Working temperature: From -25 °C to +110 °C
- Compatibility with fluids: Mineral oils, Synthetic fluids
HFA, HFB, HFC fluids in according to ISO 2943

HYDRAULIC SYMBOL

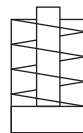

Ordering information DE - DL - DV

Series	1	2	3	4	5	6	7
DE	<input type="checkbox"/>	<input type="checkbox"/>	<input type="checkbox"/>	<input type="checkbox"/>	<input type="checkbox"/>	<input type="checkbox"/>	<input type="checkbox"/>
Example:	DE	X	20	H	A	50	P01

Series	1	2	3	4	5	6	7
DL	<input type="checkbox"/>	<input type="checkbox"/>	<input type="checkbox"/>	<input type="checkbox"/>	<input type="checkbox"/>	<input type="checkbox"/>	<input type="checkbox"/>
Example:	DL	X	20	H	A	52	P01

Series	1	2	3	4	7
DV	<input type="checkbox"/>	<input type="checkbox"/>	<input type="checkbox"/>	<input type="checkbox"/>	<input type="checkbox"/>
Example:	DV	X	20	H	P01

1 - Series

- DE** Electrical indicator
- DL** Electrical/Visual indicator
- DV** Visual indicator

2 - Type

- X** Standard type
- Y** Optional type

3 - Setting pressure

- 12** 1,5 bar
- 20** 2 bar
- 50** 5 bar
- 70** 7 bar
- 95** 9,5 bar

4 - Seals

- H** HNBR
- F** MFQ
- On request

5 - Thermostat (excluded for DV)

- A** Without thermostat

6 - Electrical connection (excluded for DV)

DEX series

- 50** EN 175301-803 connector

DLA series

- 51** EN 175301-803 clear connector with 24 V lamps
- 52** EN 175301-803 clear connector with 110 V lamps
- 71** M12 IEC 61076-2-101 clear connector with 24 V lamps

7 - Option

- P01** MP Filtri standard
- Pxx** Customer request

MP Filtri - The filter functions as described in this bulletin are valid exclusively for original MP Filtri filter elements and replacement parts. All rights reserved

The data in this publication are purely guideline. MP Filtri reserves the right to make changes to the models described herein at any time it deems fit in relation to technical or commercial requirements. The colours of the products shown on the cover are purely guideline. Copyright. All rights reserved.

Comparative table OLD - NEW code

VACUUM INDICATORS

Old code	New code
E0	VED20AA50P01
E0P01	VEB21AA50P01
E1	VEC20AA50P01
E1P01	VEA21AA50P01
E1P02	VEA21AA05P01
-	-
-	VVS16P01
VP01	VVR16P01
VOP01	VVA16P01
VSP01	WVB16P01

BAROMETRIC INDICATORS

Old code	New code	Old code	New code
FE08H1AP01	BEA08HA50P01	VP15AMP01	BVQ15HP01
FE08H1BP01	BLA08HA51P01	VP20AAP01	BVP20HP01
FE15H1AP01	BEA15HA50P01	VP20AMP01	BVQ20HP01
FE15H1BP01	BLA15HA51P01	-	-
FE15H1DP01	BLA15HA53P01	VRP01	BVA14P01
FE15H1EP01	BEM15HA41P01	VR25P01	BVA25P01
FE20H1AP01	BEA20HA50P01	V1P01	BVR14P01
FE20H1BP01	BLA20HA51P01	-	BVR25P01
FE20H1CP01	BLA20HA52P01		
FE20H1DP01	BLA20HA53P01		
FE20H1EP01	BEM20HA41P01		
FE25H1AP01	BEA25HA50P01		
FE25H1BP01	BLA25HA51P01		
VP15AAP01	BVP15HP01		

STAINLESS STEEL DIFFERENTIAL INDICATORS

Old code	New code	Old code	New code
1EX	DLY12HA50P01 - DLY12VA50P01	VB6FP01	DVY20FP01
E6X	DLY20HA50P01 - DLY20VA50P01	VB6HP01	DVY20HP01
E6XE	DLY20EA50P01	VB7FP01	DVY50FP01
E7X	DLY50HA50P01 - DLY50VA50P01	VB7HP01	DVY50HP01
E8X	DLY70HA50P01 - DLY70VA50P01	VB7VP01	DVY50VP01
-	-	VB8EP01	DVY70EP01
K7X1HP01	DLX50HA51P01	VB8FP01	DVY70FP01
K8X1HP01	DLX70HA51P01	VB8HP01	DVY70HP01
-	-	-	-
N7X	DEX50HA50P01	1VX	DVX12HP01 - DVX12VP01
N7XEP01	DEX50EA50P01	V6X	DVX20HP01 - DVX20VP01
N8X	DEX70HA50P01	V7X	DVX50HP01 - DVX50VP01
N8XEP01	DEX70EA50P01	V7XE	DVX50EP01
		V8X	DVX70HP01 - DVX70VP01
		V8XE	DVX70EP01

Comparative table OLD - NEW code

DIFFERENTIAL INDICATORS

Old code	New code	Old code	New code
1E	DLE12HA50P01 - DLE12VA50P01	NM6HA11P01	DEM20HA10P01
E6	DLE20HA50P01 - DLE20VA50P01	NM6HA31P01	DEM20HA30P01
E6E	DLE20EA50P01	NM6HA36P01	DEM20HA31P01
E6H	DLE20HA50P01	NM7HA11P01	DEM50HA10P01
E7	DLE50HA50P01 - DLE50VA50P01	NM7HA21P01	DEM50HA20P01
E7E	DLE50EA50P01	NM7HA31P01	DEM50HA30P01
E7H	DLE50HA50P01	NM7HA32P01	DEM50HA35P01
E8	DLE70HA50P01 - DLE70VA50P01	NM7HC32P01	DEM50HF35P01
E8E	DLE70EA50P01	NM7VA11P01	DEM50VA10P01
E8H	DLE70HA50P01	NM7VC11P01	DEM50VF10P01
E9	DLE95HA50P01 - DLE95VA50P01	NM8HA11P01	DEM70HA10P01
E9E	DLE95EA50P01	NM8HA31P01	DEM70HA30P01
E9H	DLE95HA50P01	NM8HA36P01	DEM70HA32P01
-	-	-	-
J1	DLE12HF50P01 - DLE12VF50P01	NR2HP01	DEA12HA50P01
J6	DLE20HF50P01 - DLE20VF50P01	NR2VP01	DEA12VA50P01
J7	DLE50HF50P01 - DLE50VF50P01	NR6EP01	DEA20EA50P01
J8	DLE70HF50P01 - DLE70VF50P01	NR6HP01	DEA20HA50P01
J9	DLE95HF50P01 - DLE95VF50P01	NR6VP01	DEA20VA50P01
-	-	NR7HP01	DEA50HA50P01
KR21HP01	DLA12HA51P01	NR7VP01	DEA50VA50P01
KR21VP01	DLA12VA51P01	NR8EP01	DEA70EA50P01
KR31HP01	DLA30HA51P01	NR8HP01	DEA70HA50P01
KR61HP01	DLA20HA51P01	NR8VP01	DEA70VA50P01
KR61VP01	DLA20VA51P01	NR9HP01	DEA95HA50P01
KR62HP01	DLA20HA52P01	NR9VP01	DEA95VA50P01
KR62VP01	DLA20VA52P01	-	-
KR71HP01	DLA50HA51P01	U3HP01	DVM30HP01
KR71VP01	DLA50VA51P01	U6HP01	DVM20HP01
KR72HP01	DLA50HA52P01	U6VP01	DVM20VP01
KR72VP01	DLA50VA52P01	U7HP01	DVM50HP01
KR81HP01	DLA70HA51P01	U7VP01	DVM50VP01
KR81VP01	DLA70VA51P01	U8VP01	DVM70VP01
KR82HP01	DLA70HA52P01	-	-
KR91HP01	DLA95HA51P01	1V	DVA12HP01 - DVA12VP01
-	-	V6	DVA20HP01 - DVA20VP01
NE2HTP01	DTA12HF70P01	V6E	DVA20EP01
NE2VSP01	DTA12VF70P01	V6H	DVA20HP01
NE6HSP01	DTA20HF70P01	V7	DVA50HP01 - DVA50VP01
NE6HTP01	DTA20HF70P01	V7E	DVA50EP01
NE6VSP01	DTA20VF70P01	V7H	DVA50HP01
NE6VTP01	DTA20VF70P01	V8	DVA70HP01 - DVA70VP01
NE7HSP01	DTA50HF70P01	V8E	DVA70EP01
NE7HTP01	DTA50HF70P01	V9	DVA95HP01 - DVA95VP01
NE7VSP01	DTA50VF70P01	V9E	DVA95EP01
NE7VTP01	DTA50VF70P01	-	-
NE8HSP01	DTA70HF70P01	Z2HP01	DVM12HP01
NE8HTP01	DTA70HF70P01	Z2VP01	DVM12VP01
NE8VSP01	DTA70VF70P01	Z6EP01	DVM20EP01
NE8VTP01	DTA70VF70P01	Z6HP01	DVM20HP01
NE9VSP01	DTA70VF70P01	Z6VP01	DVM20VP01
NE9VTP01	DTA70VF70P01	Z7HP01	DVM50HP01
NE9VTP01	DTA95VF70P01	Z7VP01	DVM50VP01
NE9VTP01	DTA95VF70P01	Z7XHP01	DVY70HP01
NE9VTP01	DTA95VF70P01	Z8EP01	DVM70EP01
NE9VTP01	DTA95VF70P01	Z8HP01	DVM70HP01
NE9VTP01	DTA95VF70P01	Z8VP01	DVM70VP01
NE9VTP01	DTA95VF70P01	Z9HP01	DVM95HP01

Notes

A series of horizontal dotted lines for taking notes, spanning the width of the page.

Notes

A series of horizontal dotted lines for taking notes, filling most of the page.



New Headquarters:

MP FILTRI S.p.A. Italy

Via 1° Maggio, n. 3
20060 Pessano con Bornago
(Milan) Italy
Tel. +39.02/95703.1
Fax +39.02/95741497-95740188
email: sales@mpfiltri.com
www.mpfiltri.com

GREAT BRITAIN

MP FILTRI U.K. Ltd.

Bourton Industrial Park
Bourton on the Water
Gloucestershire GL54 2HQ UK
Phone: +44.01451-822522
Fax: +44.01451-822282
email: sales@mpfiltri.co.uk
www.hydraulicparticlecounter.com
www.mpfiltri.com

GERMANY

MP FILTRI Germany GmbH

Hans - Wilhelmi - Straße 2
DE-66386 St. Ingbert
Phone: +49.(0)6894-95652-0
Fax: +49.(0)6894-95652-20
email: sales@mpfiltri.de
www.mpfiltri.com

FRANCE

MP FILTRI FRANCE Sas

Parc d'activités des Chanteraines
8 rue du Commandant d'Estienne
d'Orves, Immeuble D3
92396 Villeneuve la Garenne - France
Phone: +33(0)1.40.86.47.00
Fax: +33(0)1.40.86.47.09
email: sales@mpfiltrifrance.com
www.mpfiltri.com

USA

MP FILTRI USA Inc.

2055 Quaker Pointe Drive
Quakertown, PA 18951
Phone: +1.215-529-1300
Fax: +1.215-529-1902
email: sales@mpfiltriusa.com
www.mpfiltriusa.com

CANADA

MP FILTRI CANADA Inc.

8831 Keele Street, Concord,
Ontario L4K 2N1, Canada
Phone: +1.905-303-1369
Fax: +1.905-303-7256
email: mail@mpfiltricanada.com
www.mpfiltricanada.com

RUSSIAN FEDERATION

ITALFILTRI

Yuryevskiy Pereulok 13 a, Building 1
111020 Moscow, Russia
Phone/Fax: +7(495)220-94-60
email: mpfiltrirusia@yahoo.com
www.mpfiltri.ru

CHINA

MP FILTRI (Shanghai) Co. Ltd.

1280 Lianxi Road, 8 Bld - 2 Floor
Shanghai, Pudong
201204 P.R. China
Phone: + 86.21-58919916
Fax: + 86.21-58919667
email: sales@mpfiltrishanghai.com
www.mpfiltri.com

INDIA

MP FILTRI INDIA Pvt. Ltd.

Plot-7F, Raj Pinnacle
Beside RMZ Centennial,
Brookefield Road, Whitefield,
Bangalore 560048 - India
Phone: +91-80-4147 7444/4146 1444
Fax: +91-80-41461888
email: sales@mpfiltri.co.in
www.mpfiltri.com

Operating & Maintenance Manual



Filters are utilised to remove contaminant from hydraulic systems.
 Long working life of the hydraulic components and correct use of the hydraulic systems can be assured only when maintenance is performed correctly and at regular intervals.

It is essential to use indicators that serve to inform the user of the need to change the cartridge.

Effective contamination control can be assured only by the correct use of clogging indicator.

INSTALLATION

A

Check that the pressure value of the selected filter is higher than the system's maximum operating pressure (the maximum pressure value is shown on the dataplate).

B

Check that the filter body contains the filter cartridge.

C

Check that the operating fluid is compatible with the material of the body, cartridge, and seals.

D

Install the filter in an accessible position for correct and trouble-free maintenance and visibility.

E

Start the machine and check for the absence of oil leaks from the filter and relative fittings.

F

Repeat the visual inspection when the system arrives at the operating temperature of the oil.

MAINTENANCE

A

All maintenance operations must be performed only by suitably trained personnel.

B

The hydraulic system must be depressurised before performing maintenance operations.

C

Maintenance must be carried out using suitable tools and containers to collect the fluid contained in the filter body. Spent fluids must be disposed of in compliance with statutory legislation.

D

Do not use naked flames during maintenance operations.

E

Use the utmost caution in relation to the temperature of the fluid. High temperatures can lead to residual pressure with resulting undesirable movements of mechanical parts.

CHANGING THE FILTER ELEMENT

A

The date on which the filter elements are changed must be entered in the machine datasheet.

B

Spare parts installed must be in compliance with the specifications given in the machine operating and maintenance manual.

C



Filter bodies and tools must be thoroughly cleaned prior to each maintenance operation.

D



After having opened the filter to change the filter element, check the condition of the seals and renew them if necessary.



Clean thoroughly before reassembling.

MAINTENANCE TOOLS



Type	Indicators Series	Body	
		Type	A/F
Clogging	VR		11
	VP		27
	FE		
Differential	V		
	E		
	J		
	NR	30	
	KR		
	U		

Series	Filter	Cover screw	
		Type	A/F
MPF	MPF 020		10
	MPF 030		
	MPF 100		
	MPF 104		
	MPF 110		
	MPF 120		
	MPF 181		15
	MPF 182		
	MPF 184		
	MPF 450		13
	MPF 451		
	MPF 750		

Series	Filter	Air Breather screw	
		Type	A/F
MPT	MPT 025		3
	MPT 027		
	MPT 101	-	-
	MPT 104		3
	MPT 110		
	MPT 114		
	MPT 120		

Series	Filter	Cover screw		Air Breather screw		Spring retainer nut	
		Type	A/F	Type	A/F	Type	A/F
MPH	MPH 104		-		3		13
	MPH 110						
	MPH 114						
	MPH 120						
	MPH 250						
	MPH 630						
	MPH 660						
	MPH 850						

Series	Filter	Spring retainer nut	
		Type	A/F
MPI	MPI 100		13
	MPI 250		17
	MPI 630		
	MPI 850		22

Series	Filter	Cover screw	
		Type	A/F
FRI	FRI 025		3
	FRI 040		5
	FRI 100		6
	FRI 250	8	
	FRI 255	-	-
	FRI 630		8
	FRI 850		

Series	Filter	Knob nut	
		Type	A/F
RF2	RF2 250		10
	RF2 350		

CHANGING THE FILTER ELEMENT IN MPF FILTERS

1

Depressurise the system and clean the filter.

2

Unscrew the screws remove out the cover.

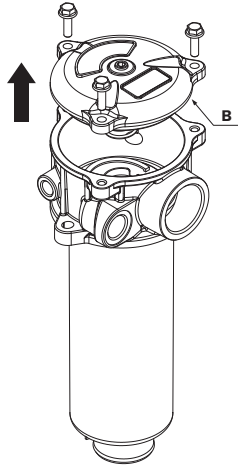

Fig. 1

3

Take out the filter element and bowl using the handle on the filter element.

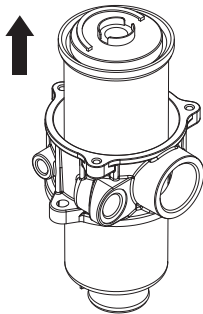

Fig. 2

4

Remove the filter element from the bowl. Collect the spent oil and cartridge in a suitable container and dispose of them in compliance with statutory legislation.

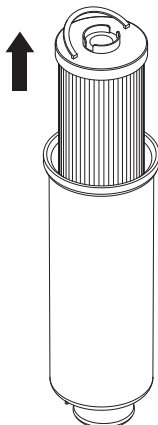

Fig. 3

5

Using the new filter element, lubricate seal with the operating fluid. Put the filter element into the bowl.

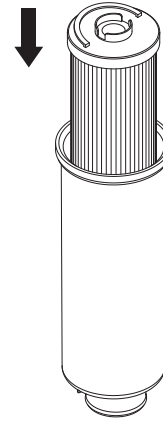

Fig. 4

6

Check the condition of the bowl seal "A" (see Fig. 5): if renewing, lubricate the new seal with the operating fluid before installing.

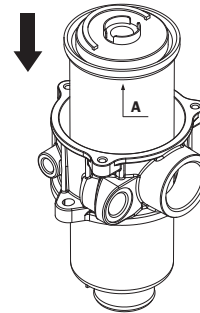

Fig. 5

7

Check the condition of the cover seal "B" (see Fig. 1): if renewing, lubricate the new seal with the operating fluid before installing.

Screw the crews of the cover.

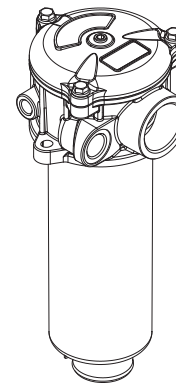

Fig. 6

8

Start the machine and check for the absence of leaks. Repeat the check when the machine has reached its operating temperature.

CHANGING THE FILTER ELEMENT IN MPT FILTERS

1

Depressurise the system and clean the filter.

2

Unscrew the cover.

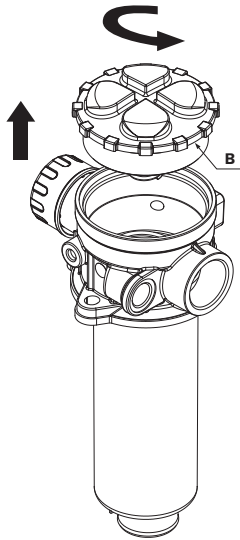

Fig. 1

3

Take out the filter element and bowl using the handle on the filter element.

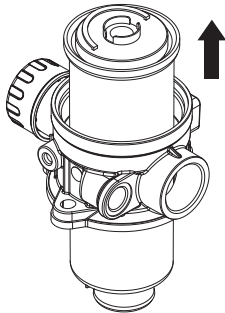

Fig. 2

4

Remove the filter element from the bowl. Collect the spent oil and cartridge in a suitable container and dispose of them in compliance with statutory legislation.

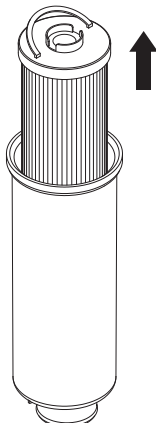

Fig. 3

5

Using the new filter element, lubricate seal with the operating fluid. Put the filter element into the bowl.

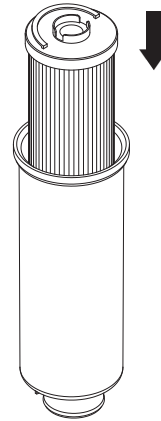

Fig. 4

6

Check the condition of the bowl seal "A" (see Fig. 5): if renewing, lubricate the new seal with the operating fluid before installing.

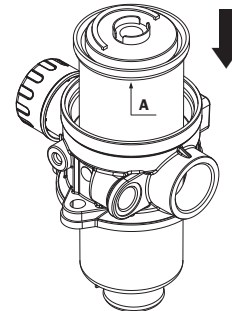

Fig. 5

7

Check the condition of the cover seal "B" (see Fig. 1): if renewing, lubricate the new seal with the operating fluid before installing.

Screw the cover.

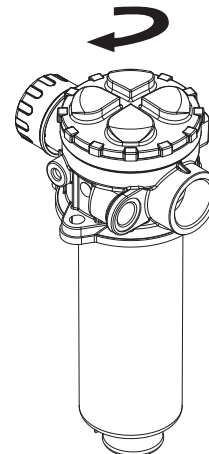

Fig. 6

8

Start the machine and check for the absence of leaks. Repeat the check when the machine has reached its operating temperature.

CHANGING THE FILTER ELEMENT IN MPH - MPI FILTERS

1

Depressurise the system and clean the filter.

Fig. 1 MPH 104 - 110
MPH 114 - 120

2

Unscrew the cover.

Fig. 2 MPH 250 - 630

2

Unscrew the nuts "A" from the pin "A1" but do not remove.
Push the cover "1" ==> turn on the right "2" ==> take out the cover "3"

Fig. 3 MPH 660

2

Unscrew the screws and remove the cover.

Fig. 4 MPH 850

2

Unscrew the screws and remove the cover.

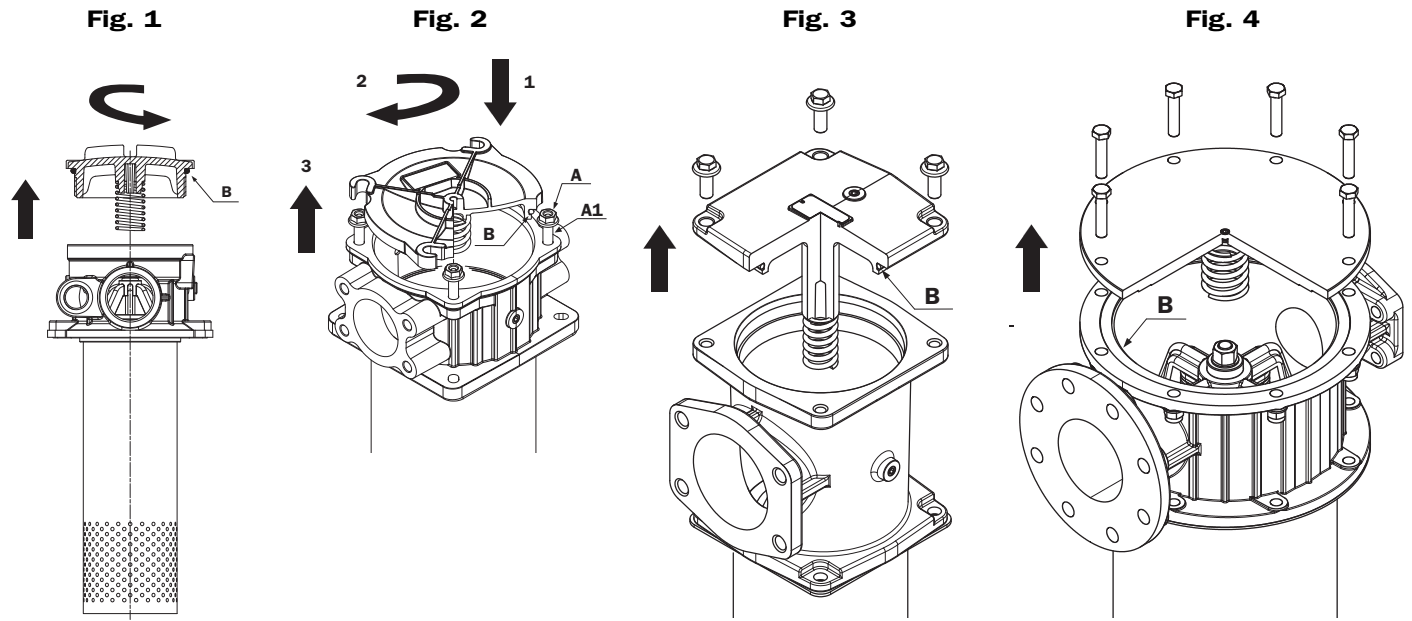

Fig. 1

Fig. 2

Fig. 3

Fig. 4

3

Take out insert assembly +
filter element.

4

Unscrew and remove
nuts + spring "E" from
the threaded pin "G".

5

Connect the filter element "D"
to the insert assembly "C".

Remove the filter element "D" from
the insert assembly "C".

Screw the nuts + spring "E"
from the threaded pin "G".

Collect the spent oil and cartridge
in a suitable container and
dispose of them in compliance
with statutory legislation.

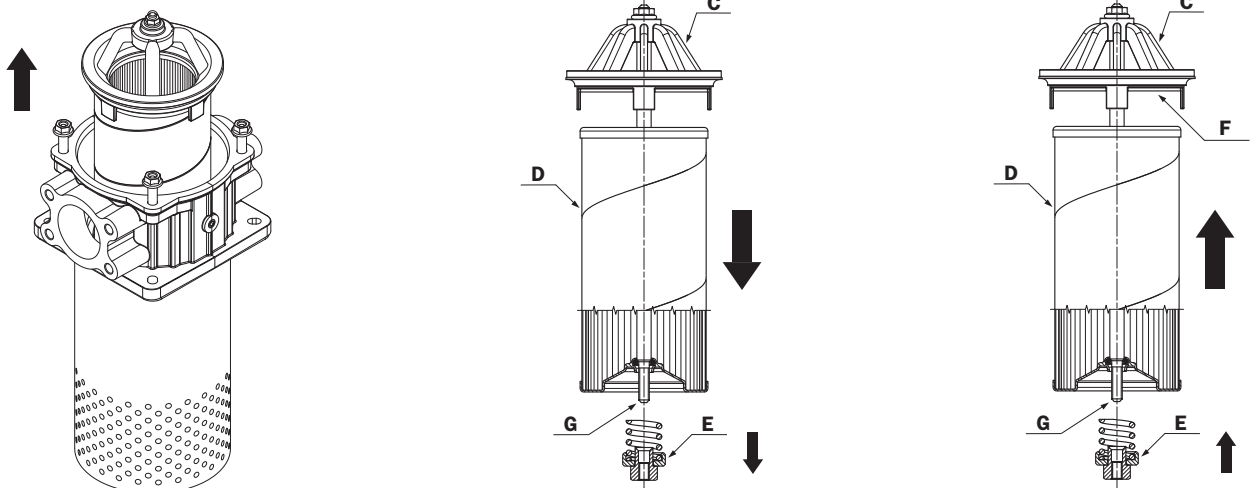

5a

Screw the nuts + spring "E" up to the contact with the chamfer on the threaded pin "G".
Chamfer "H" of the threaded pin.

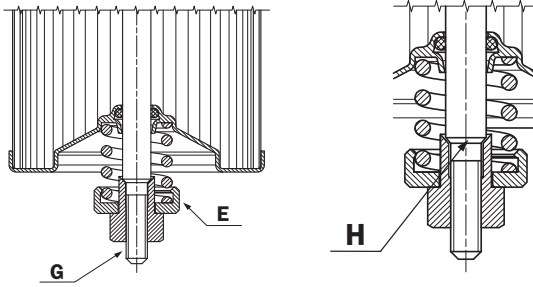
**6**

Check the condition of the stand seal "B":
if renewing, lubricate the new seal with the operating fluid before installing.
Put in insert assembly and filter element.

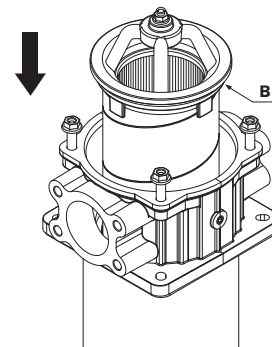
**7**

Check the condition of the cover seal "B":
if renewing, lubricate the new seal with the operating fluid before installing.

Fig. 1**Fig. 2****Fig. 3****Fig. 4**

Fig. 1 MPH 104 - 110
MPH 114 - 120

Fig. 2 MPH 250 - 630

Fig. 3 MPH 660

Fig. 4 MPH 850

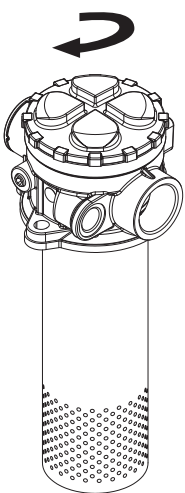
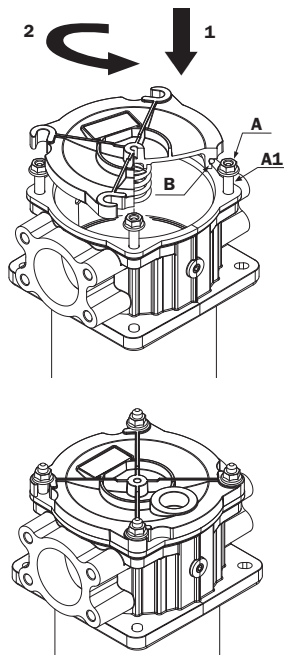
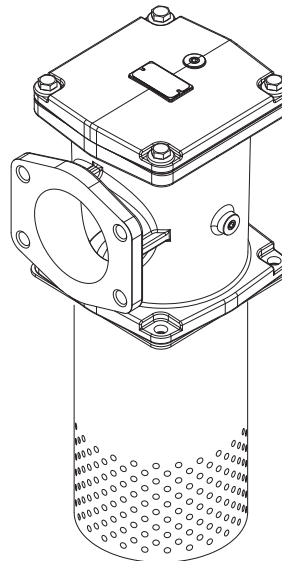
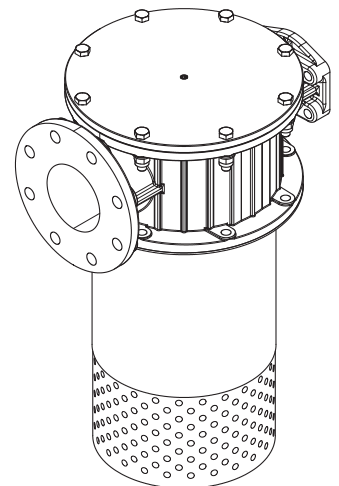
8

Screw the cover.

8

Push the cover "1" ==> turn to the left "2" ==> Screw the nuts "A" to the pin "A1".

8

Screw the screws of the cover.

8

Screw the screws of the cover.

9

Start the machine and check for the absence of leaks.
Repeat the check when the machine has reached its operating temperature.

CHANGING THE FILTER ELEMENT IN FRI FILTERS

1

Depressurise the system and clean the filter.

2

Unscrew the screws take out the cover.

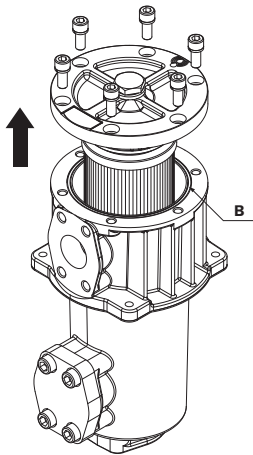

Fig. 1

3

Remove the filter element and cover from the body of the filter. Remove the filter element from the cover/by-pass valve.

Collect the spent oil and cartridge in a suitable container and dispose of them in compliance with statutory legislation.

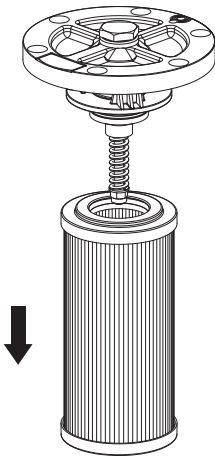

Fig. 2

4

Lubricate the filter element seal with the operating fluid.

Place the filter element on the cover/by-pass valve.

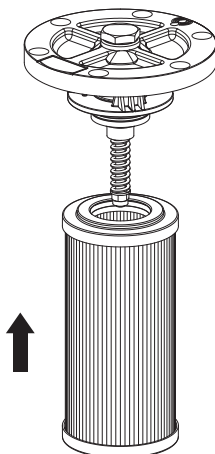

Fig. 3

5

Lubrificate la guarnizione inferiore dell'elemento filtrante con il fluido di lavoro prima dell'installazione.

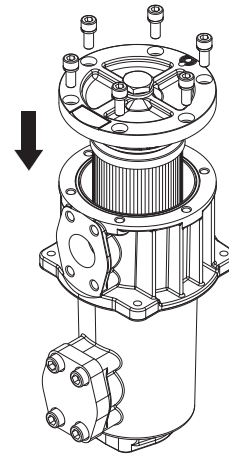

Fig. 4

6

Check the condition of the cover seal "B" (see Fig. 1):
if renewing, lubricate the new seal with the operating fluid before installing.

Screw the screws of the cover.

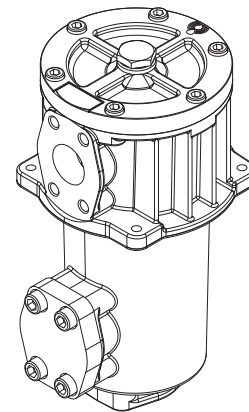

Fig. 5

7

Start the machine and check for the absence of leaks.
Repeat the check when the machine has reached its operating temperature.

CHANGING THE FILTER ELEMENT IN FRI 255 FILTERS

1

Depressurise the system and clean the filter.

2

Unscrew the cover.
Remove the cover and the filter element from the body of the filter.

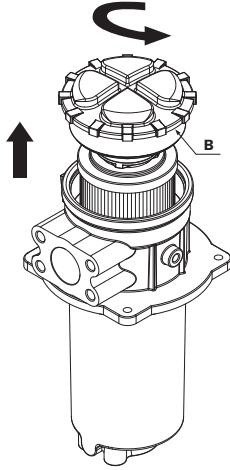

Fig. 1

3

Remove the filter element from the cover/by-pass valve.
Collect the spent oil and cartridge in a suitable container and dispose of them in compliance with statutory legislation.

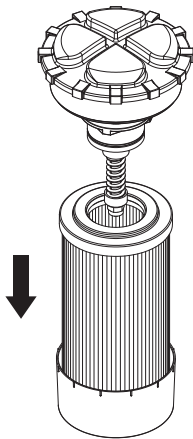

Fig. 2

4

Remove the contamination retainer binder from the filter element and clean.
Place the the retainer binder on the new filter element.

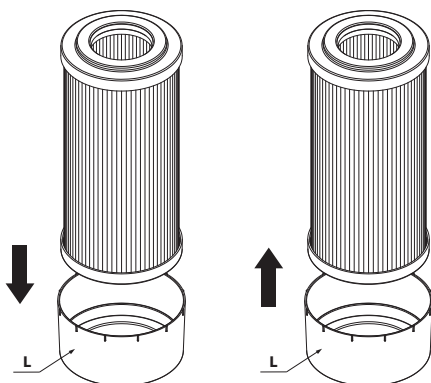

Fig. 3

5

Lubricate the filter element seal with the operating fluid.
Place the filter element on the cover/by-pass valve.

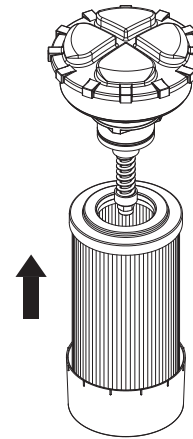

Fig. 4

6

Lubricate bottom seal of filter element with the operating fluid before installing.

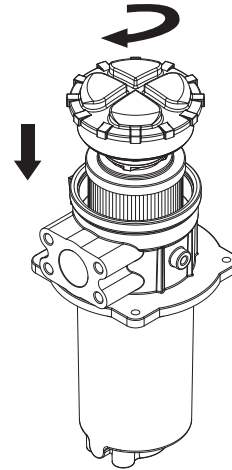

Fig. 5

7

Check the condition of the cover seal "B" (see Fig. 1):
if renewing, lubricate the new seal with the operating fluid before installing.

Screw the cover.

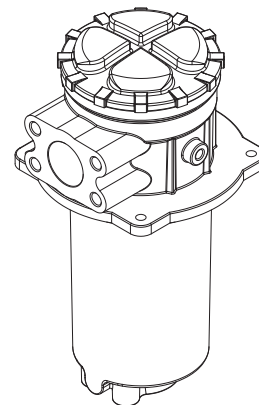

Fig. 6

8

Start the machine and check for the absence of leaks. Repeat the check when the machine has reached its operating temperature.

CHANGING THE FILTER ELEMENT IN RF2 250 - 350 FILTERS

1

Depressurise the system and clean the filter.

2

Unscrew the cover.

Collect the spent oil in a suitable container and dispose in compliance with statutory legislation.

Remove the cover and the filter element from the body of the filter.

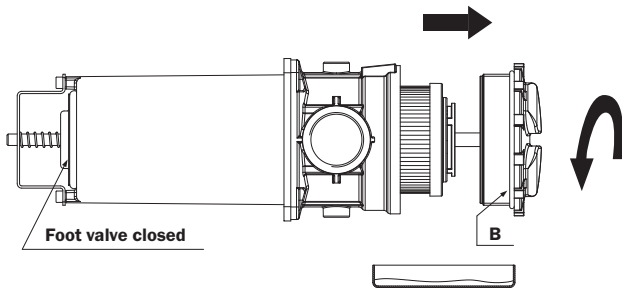

Fig. 1

3

Unscrew thread spigot "3" nut "2", remove spigot, nut and support filter element "1".

Remove the filter element from the cover/by-pass valve.

Collect the spent filter element in a suitable container and dispose of them in compliance with statutory legislation.

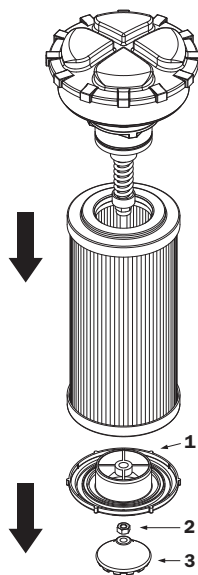

Fig. 2

4

Lubricate the filter element seals with the operating fluid.

Place the filter element on the cover/by-pass valve.

Fixed support element "1" and screw nut "2" and thread spigot "3": hand tightening.

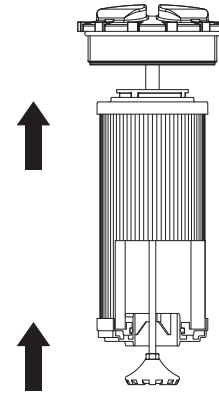

Fig. 3

5

Check the condition of the cover seal "B" (see Fig. 1):

if renewing, lubricate the new seal with the operating fluid before installing.

Screw the cover.

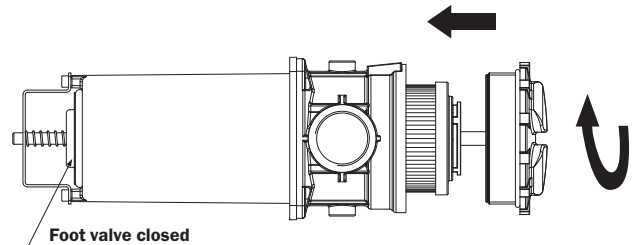

Fig. 4

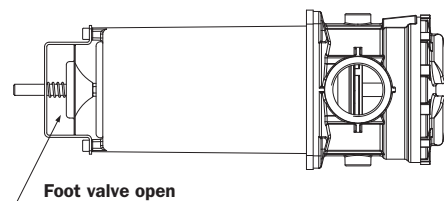

Fig. 5

6

Start the machine and check for the absence of leaks.

Repeat the check when the machine has reached its operating temperature.

MAINTENANCE AIR BREATHER

MPT 025 - 027 - 110 - 114

MPH 110 - 114

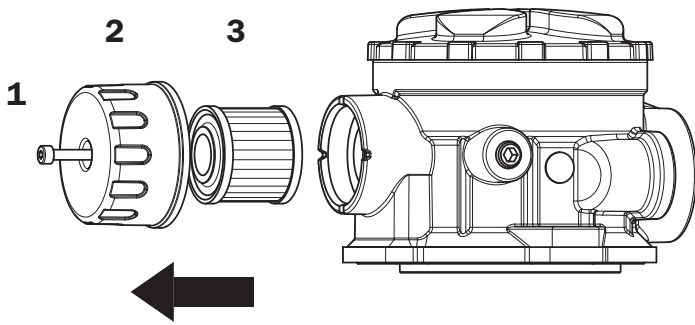

1
Unscrew the screw "1" remove the cover "2" and filter element "3".

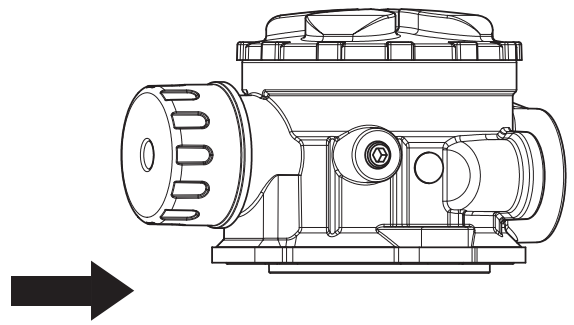

2
Assembling item "1" - "2" - "3".

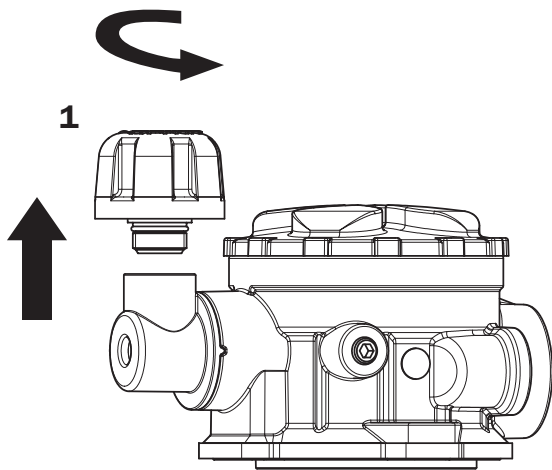

1
Unscrew air breather "1".

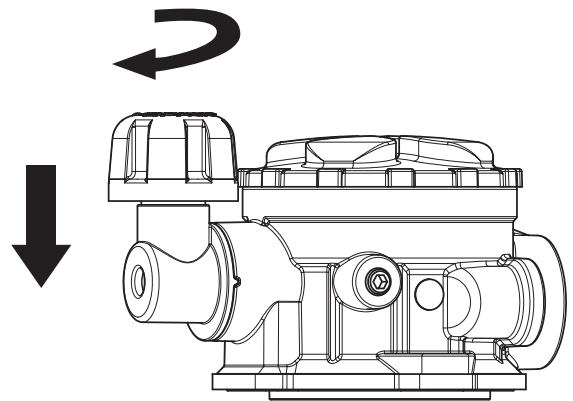

2
Screw new air breather "1".